

Series 20
Axial Piston Pumps

Technical
Information

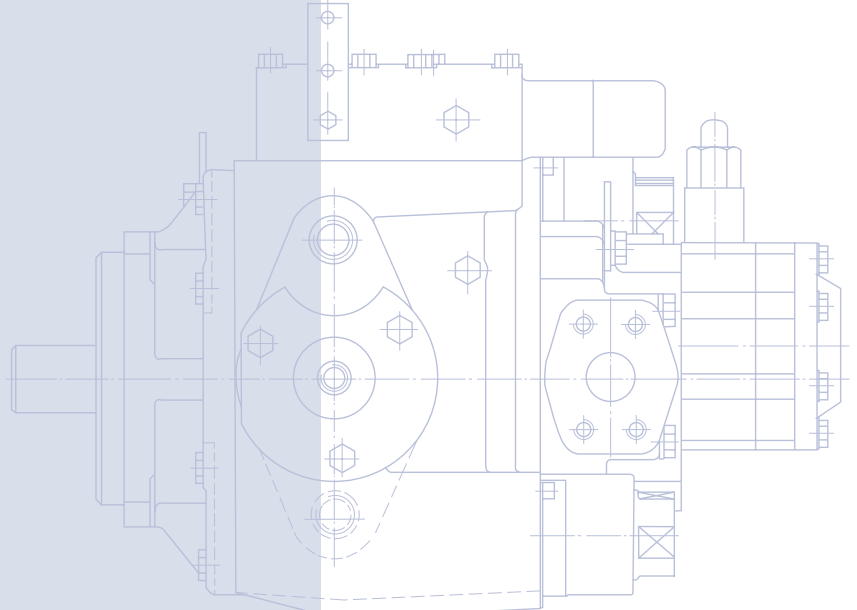
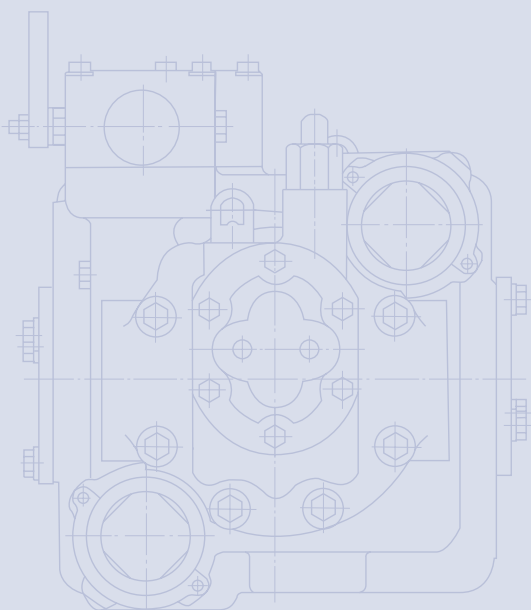
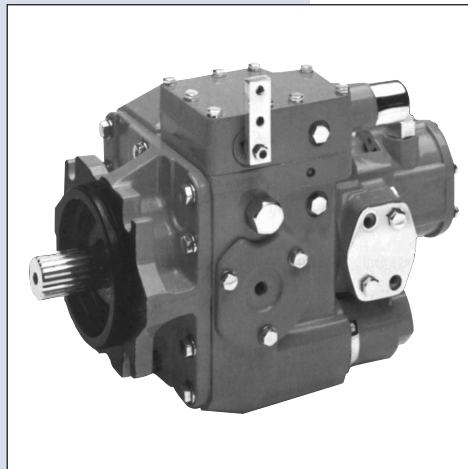
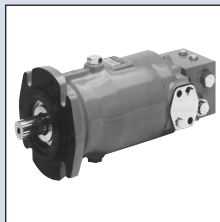
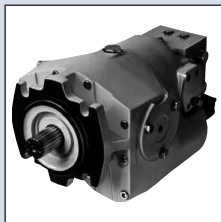

INTRODUCTION

Sauer-Danfoss a world leader in hydraulic power systems has developed a family of axial piston pumps.

DESCRIPTION

Sauer-Danfoss axial piston variable displacement pumps are of swash plate design with variable flow capability suitable for hydrostatic transmissions with closed loop circuit. Tilting the swash plate to the opposite side of the neutral or zero displacement position reverses flow direction.

Sauer-Danfoss axial piston variable displacement pumps are well engineered and easy to handle.

The full-length shaft with a highly efficient tapered roller bearing arrangement offers a high loading capacity for external radical forces.

The hydro-mechanical servo displacement control maintains the selected swash plate position and hence pumps displacement.

Upon release of the control handle, the swash plate automatically returns to zero position and the flow reduces to zero.

High case pressures can be achieved without leakage even at the lowest temperatures by using suitable shaft seals.

The servo valve arrangement offers the facility to incorporate function regulators and remote control systems.

Axial piston units are designed for easy servicing. Complete dismantling and reassembly can be carried out with standard hand tools, and all components or sub-assemblies are replaceable.

Axial piston variable displacement pumps of the Sauer-Danfoss pattern are made by licensed producers worldwide, providing consistent service and fully interchangeable parts.

TYPICAL MARKETS

- Industrial
- Mining
- Transit Mixer
- Utility Vehicles

© 1999 -2001, Sauer-Danfoss

Sauer-Danfoss can accept no responsibility for possible errors in catalogues, brochures and other printed material. Sauer -Danfoss reserves the right to alter its products without prior notice. This also applies to products already ordered provided that such alterations can be made without subsequent changes being necessary in specifications already agreed. All trademarks in this material are properties of the respective companies. Sauer-Danfoss and the Sauer-Danfoss logotype are trademarks of the Sauer-Danfoss Group. All rights reserved.

Front page: F000 234, F000 248, F000 150, F000 249

CONTENTS

General description	2
Introduction	2
Description	2
Typical markets	2
Sectional view	4
Axial piston variable displacement pump	4
System circuit description	5
Pump and motor circuit description	5
Pump circuit schematic	5
Technical specification	6
Technical parameters	6
Design	6
Type of mounting	6
Pipe connections	6
Direction of rotation	6
Installation position	6
External drain fluid loss	6
Hydraulic parameters	7
System pressure range, input p_1	7
System pressure range, output p_2	7
Case pressure	7
Hydraulic fluid	7
Hydraulic fluid temperature range	7
Viscosity range	7
Filtration	7
Shaft load	7
Technical data	8
Determination of nominal pump size	8
Servo displacement control	9
Pump flow direction	9
Reversing time	10
Reset time	11
Changing reversing and reset time	11
Dimensions – Frame size 033, 052, 070 and 089 cm³	12
Outline drawing, configuration PS, displacement control VML 1	12
Tapered shaft end	16
Pump configuration AA 010, displacement control VML 1	17
Dimensions – Frame size 119 cm³	18
Pump configuration PS, displacement control VML 1	18
Dimensions – Frame size 166 cm³	19
Pump configuration PS, displacement control VML 1	19
Dimensions – Frame size 227 cm³	20
Pump configuration PS, displacement control VML 1	20
Dimensions – Frame size 334 cm³	21
Pump configuration PS, displacement control VML 1	21
Dimensions – Frame size 119, 166, 227 and 334 cm³	23
Pump configuration AA 010, displacement control VML 1	23

AXIAL PISTON VARIABLE DISPLACEMENT PUMP

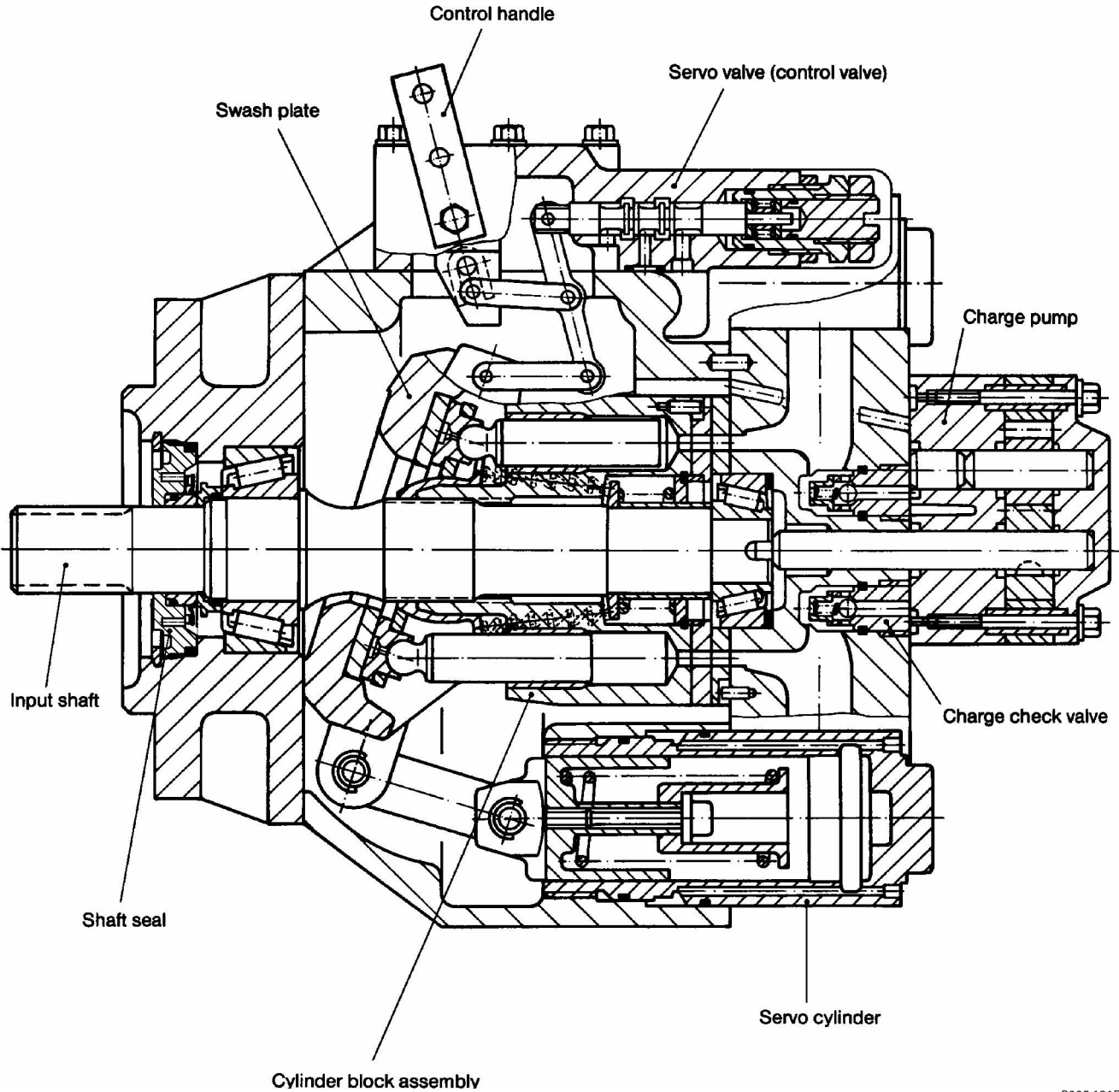

P005 121E

PUMP AND MOTOR CIRCUIT DESCRIPTION

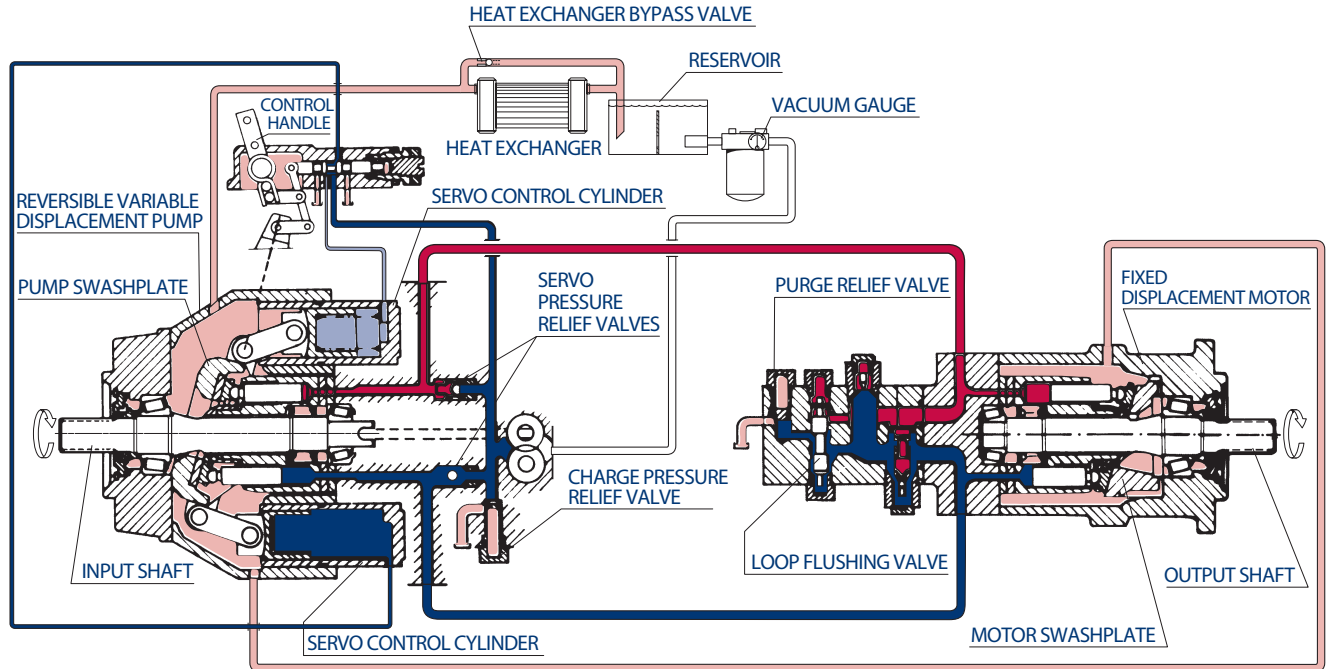

WORKING LOOP (HIGH PRESSURE)
 WORKING LOOP (LOW PRESSURE)
 CONTROL FLUID
 SUCTION LINE
 CASE DRAIN FLUID

P000 027E

Above figure shows schematically the function of a hydrostatic transmission using an axial piston variable displacement pump and a fixed displacement motor.

PUMP CIRCUIT SCHEMATIC

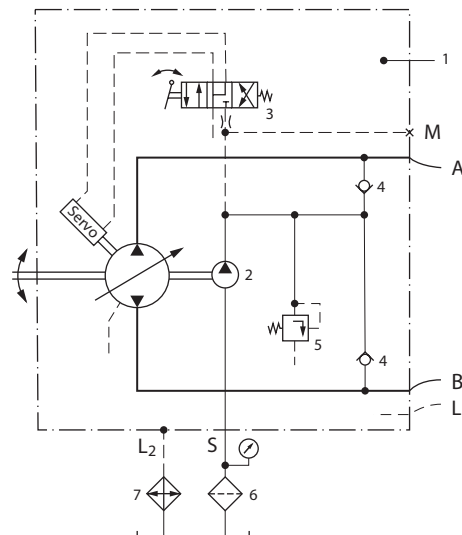

Designation:

- 1 = Variable displacement pump
- 2 = Charge pump
- 3 = Servo control valve
- 4 = Charge check valve
- 5 = Charge relief valve
- 6 = Filter
- 7 = Heat exchanger

Ports:

- A, B = Main pressure ports (working loop)
- S = Suction port - charge pump
- L1, L2 = Drain ports
- M = Gauge port - charge pressure

P000 012

TECHNICAL PARAMETERS

Design

Axial piston pump of swash plate design, with variable displacement.

Type of mounting

SAE four bolt flanges.

Pipe connections

Main pressure ports: SAE split flange

Remaining ports: SAE O-ring boss

Direction of rotation

Clockwise or counterclockwise (viewing from the input shaft).

Installation position

Optional; pump housing must be always filled with hydraulic fluid.

External drain fluid loss

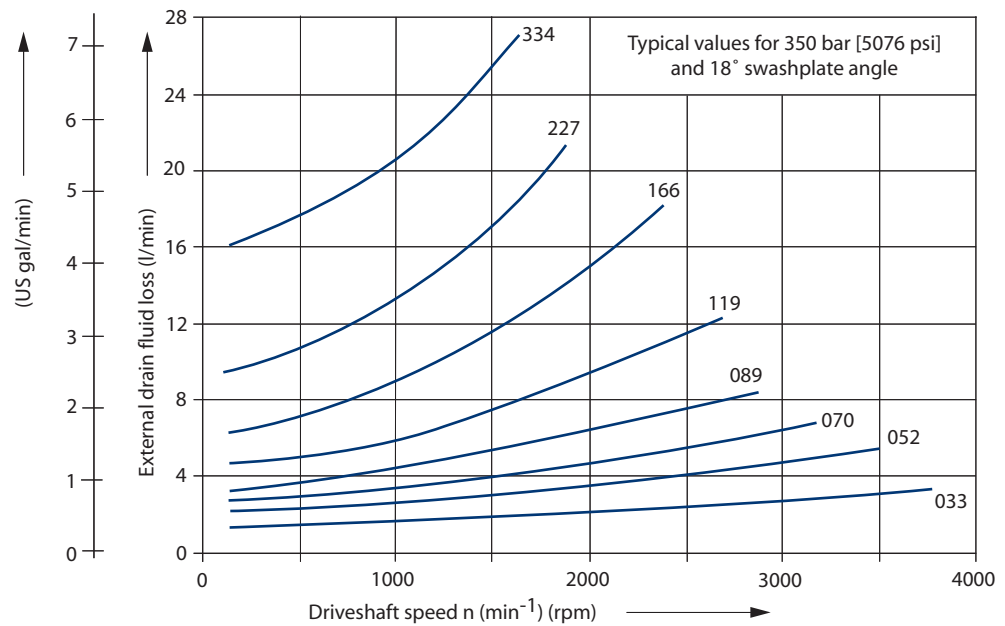

P005 105E

HYDRAULIC PARAMETERS

System pressure range, input p_1

Variable displacement pump:

Charge pressure nominal: 13 bar [189 psi] above case pressure

Charge pressure minimum: 8 bar [116 psi], intermittent only

Charge pump input pressure:

Min. allowable pressure, continuous = 0.75 bar [10.9 psi] absolute

Min. allowable pressure, intermittent = 0.50 bar [7.3 psi] absolute (for cold start)

Charge pump output pressure:

Max. operating pressure = 35 bar [508 psi] above case pressure

System pressure range, output p_2

Pressure on port A or B: Max. operating pressure $\Delta p = 420$ bar [6092 psi]

Max. high pressure setting $\Delta p = 460$ bar¹ [6672 psi]

¹only with POR-valve

Case pressure

Max. rated pressure = 2.5 bar [36.3 psi]

Intermittent = 5.0 bar [72.5 psi]

Hydraulic fluid

Refer to Sauer-Danfoss publications *Hydraulic Fluids and Lubricants and Experience with Bio Fluids for biodegradable hydraulic fluids*.

Hydraulic fluid temperature range

$\vartheta_{\min} = -40$ °C [-40 °F]

$\vartheta_{\max} = 95$ °C [203 °F]

Viscosity range

$v_{\min} = 7$ mm²/s [49 SUS*]

$v_{\max} = 1000$ mm²/s [4630 SUS*] (intermittent cold start)

Recommended viscosity range: 12 - 60 mm²/s [66 - 280 SUS*]

*SUS (Saybolt Universal Second)

Filtration

Required cleanliness level: ISO 4406 - 1999 Code 22/18/13 or better. Refer to Sauer-Danfoss publication *Hydraulic Fluids and Lubricants and Design Guideline for Hydraulic Fluid Cleanliness*.

Shaft load

The pump will accept radial and axial loads on its shaft, the maximum capacity being determined by direction and point of application of the load. Please contact your Sauer-Danfoss representative.

HYDRAULIC PARAMETERS (continued)

Technical data										
		Dimension	Frame size							
			033	052	070	089	119	166	227	334
Max. displacement		cm ³ [in ³]	33.3 [2.03]	51.6 [3.15]	69.8 [4.26]	89.0 [5.43]	118.7 [7.24]	165.8 [10.12]	227.3 [13.87]	333.7 [20.36]
Charge pump displacement	options	cm ³ [in ³]	12.30 [0.75]		18.03 [1.10]		18.85 [1.15]	32.80 [2.00]		65.50 [4.00]
			18.03 [1.10]		12.30 [0.75]		32.80 [2.00]	65.50 [4.00]		-
Minimum speed		min ⁻¹ (rpm)	500							
Rated speed 1		min ⁻¹ (rpm)	3800	3500	3200	2900	2700	2400	2100	1900
Maximum swash plate angle		degree	±18							
Mass moment of inertia of rotating group (without charge pump)		kg m ² · 10 ⁻³ [lbf ft ² · 10 ⁻³]	4.34 [103.0]	8.14 [193.2]	12.34 [292.8]	17.77 [421.7]	29.11 [690.8]	50.19 [1191.0]	86.80 [2059.8]	161.40 [3830.0]
Weight		kg [lb]	45 [99]	55 [121]	63 [139]	78 [172]	124 [273]	164 [362]	212 [467]	270 [595]

¹ for higher speeds contact your Sauer–Danfoss representative

Determination of nominal pump size

Unit:	Metric system:	Inch system
Pump output flow	$Q = \frac{V_g \cdot n \cdot \eta_v}{1000}$ l/min	$Q = \frac{V_g \cdot n \cdot \eta_v}{231}$ [gpm]
Input torque	$M = \frac{V_g \cdot \Delta p}{20 \cdot \pi \cdot \eta_m}$ Nm	$M = \frac{V_g \cdot \Delta p}{2 \cdot \pi \cdot \eta_m}$ [lbf·in]
Input power	$P = \frac{V_g \cdot n \cdot \Delta p}{600\,000 \cdot \eta_t}$ kW	$P = \frac{V_g \cdot n \cdot \Delta p}{396\,000 \cdot \eta_t}$ [hp]

Efficiency characteristic curves available on request.

V_g	= Pump displacement per revolution	cm ³ [in ³]
n	= Pump speed	min ⁻¹ (rpm)
Δp	= Hydraulic pressure differential	bar [psi]
η_v	= Pump volumetric efficiency	
η_m	= Pump mechanical efficiency	
η_t	= Pump total efficiency	

**SERVO DISPLACEMENT
CONTROL
(LINEAR RESPONSE)**

Regulated by the control handle on the servo valve, the swash plate can be infinitely varied in both directions with the help of the servo system. The pump displacement resulting from any control handle position can be established using the figures on this page. The angle of the control handle for stroke initiation and for the final position of the stroke can vary from unit to unit within the range of the tolerance band. The inter-relationship of flow direction, rotation of the pump and the control handle movement is shown below.

Pump flow direction

Flow direction changes with the direction of rotation and the control handle movement (see above).

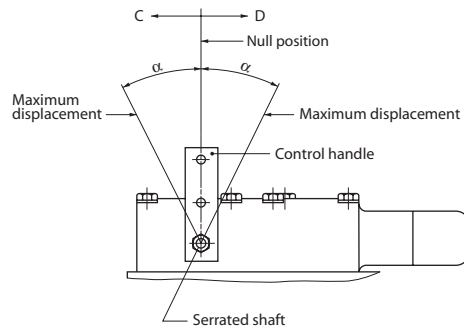

P000 013E

Pump rotation	Movement of control handle in direction	Pressure port OUT	Pressure port IN
Counter-clockwise (L)	C	B	A
	D	A	B
Clockwise (R)	C	A	B
	D	B	A

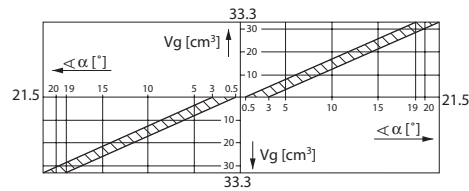

SPV 2/033

P000 014

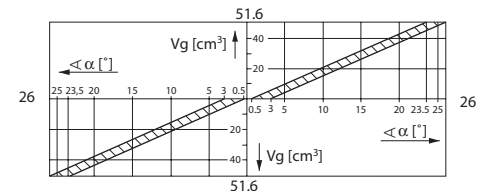

SPV 2/052

P000 015

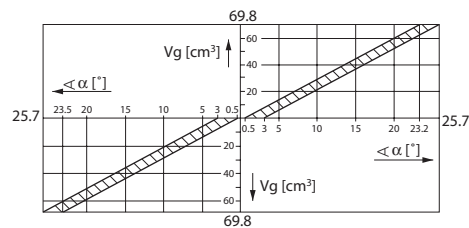

SPV 2/070

P000 016

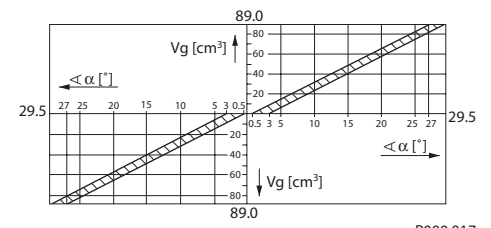

SPV 2/089

P000 017

SERVO DISPLACEMENT CONTROL (LINEAR RESPONSE) (continued)

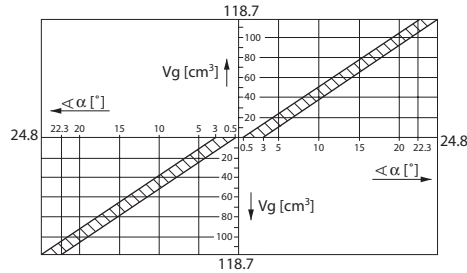

SPV 2/119

P000 018

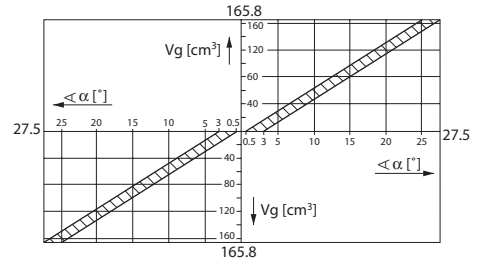

SPV 2/166

P000 019

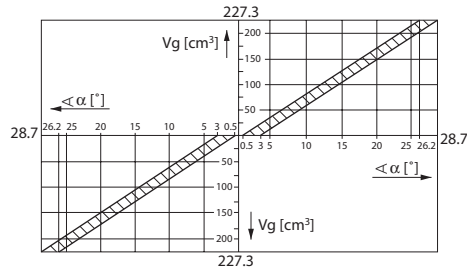

SPV 2/227

P000 020

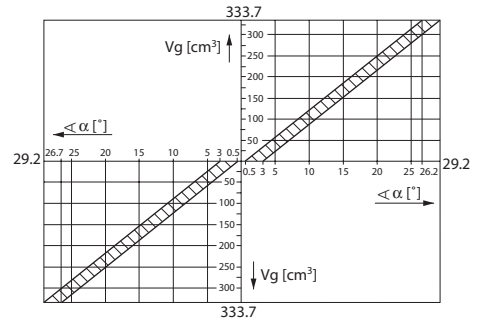

SPV 2/334

P000 021

Reversing time

Time for the directional change of the flow from Q_{max} , across zero to Q_{max} , depending on the size of the control orifice fitted in the supply port to the servo valve (see below). The values given assume movement of the control handle directly from one end position to the other.

Adjustment time of handle: < minimum reserving time

Operating pressure: $\Delta p_2 = 210 \text{ bar [3046 psi]}$

Speed: $n = 1450 \text{ min}^{-1} \text{ (rpm)}$

System temperature: 50 °C [122 °F]

Viscosity: $35 \text{ mm}^2/\text{s [164 SUS]}$

Frame size	Minimum reversing time (s) without orifice	Maximum reversing time (s) with orifice $\varnothing 0.66$ in supply port
033	0.7	5.6
052	0.7	5.6
070	1.0	9.3
089	1.1	9.0
119	1.8	15.7
166	1.8	15.3
227	3.7	42.0
334	5.6	43.8

**SERVO DISPLACEMENT
CONTROL
(LINEAR RESPONSE)
(continued)**

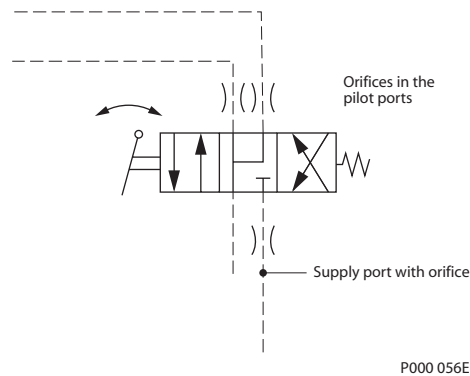

**Schematic diagram of servo valve
with alternative orifice positions**

Reset time

Time for reducing the flow from either flow direction from Q_{max} to 0 releasing the control handle.

Assuming no mechanical blockage of the control handle's free return and assuming no orifices in the pilot ports:

Operating pressure: $\Delta p_2 = 210 \text{ bar [3046 psi]}$

System temperature: $50 \text{ }^\circ\text{C [122 }^\circ\text{F]}$

Viscosity: $35 \text{ mm}^2/\text{s [164 SUS]}$

Frame size	Minimum reset time (s)
033	
052	
070	3.0
089	
119	
166	4.2
227	
334	5.4

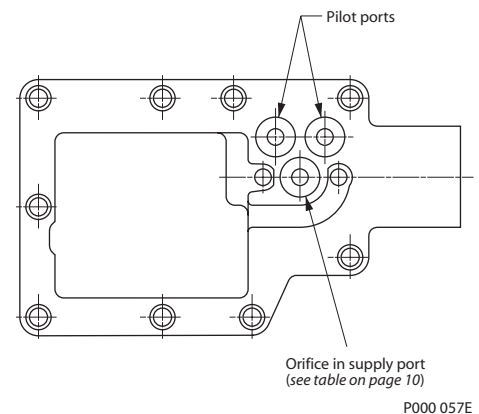

**Servo valve counter bored recesses for orifice
insert**

Changing reversing and reset time

Inserting one orifice in each of the pilot ports can extend the reversing time. The reset time will also be extended.

Inserting an orifice in one of the pilot ports only can extend the reversing time in one flow direction. The reset time will be extended only for this flow direction.

**OUTLINE DRAWING,
CONFIGURATION PS,
DISPLACEMENT
CONTROL VML 1**

- * Minimum and maximum angle α , (see section servo displacement control).
- ** Shaft spline data: spline shaft with involute spline, according to SAE handbook, 1963, class 1, fillet root side fit.

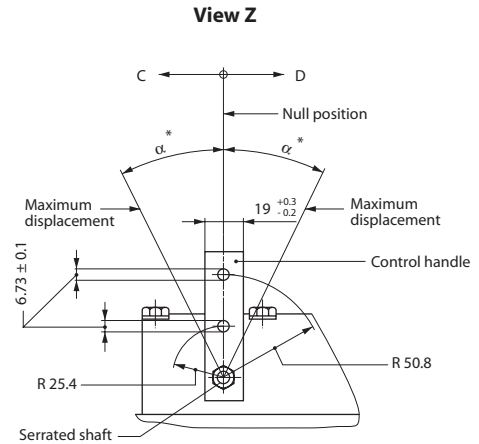

P000 022E

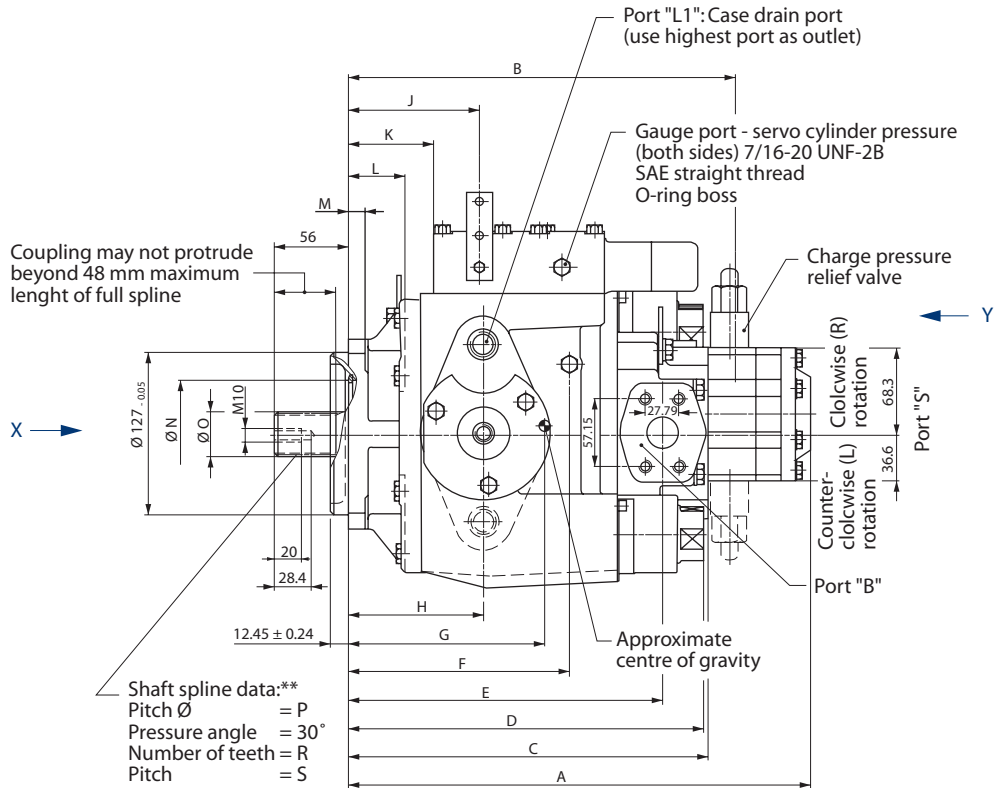

P005 106E

**OUTLINE DRAWING,
CONFIGURATION PS,
DISPLACEMENT
CONTROL VML 1
(continued)**

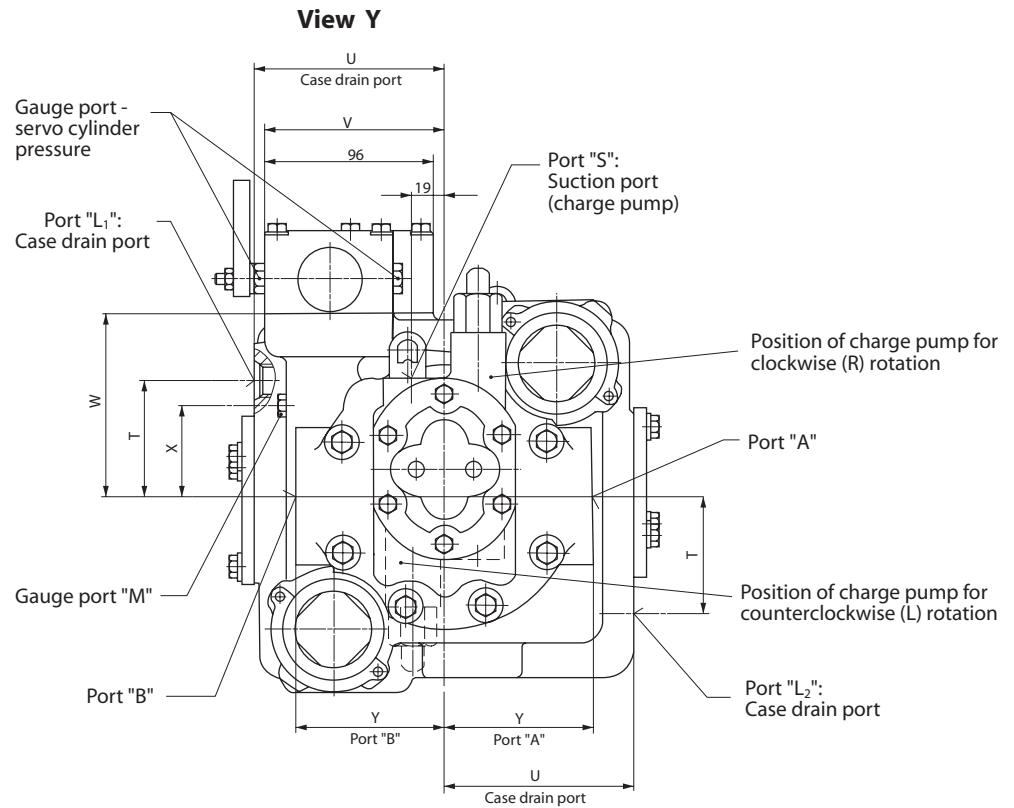

P005 107E

Max. torque for charge pump inlet port (7/8 -14 UNF - 2B) is 22 - 28 Nm [195 - 248 lbf·in].

Frame size	Port A and B	Port L₁ and L₂	Port S	Port M
033	SAE flange, size 1	7/8-14 UNF-2B SAE straight thread O-ring boss	7/16-20 UNF-2B SAE straight thread O-ring boss	7/16-20 UNF-2B SAE straight thread O-ring boss
052	SAE split flange boss 5000 psi			
070	4 threads 3/8-16 UNC-2B			
089	18 deep			

**OUTLINE DRAWING,
CONFIGURATION PS,
DISPLACEMENT
CONTROL VML 1
(continued)**

View X (for SPV 2/033 - 2/052 only)

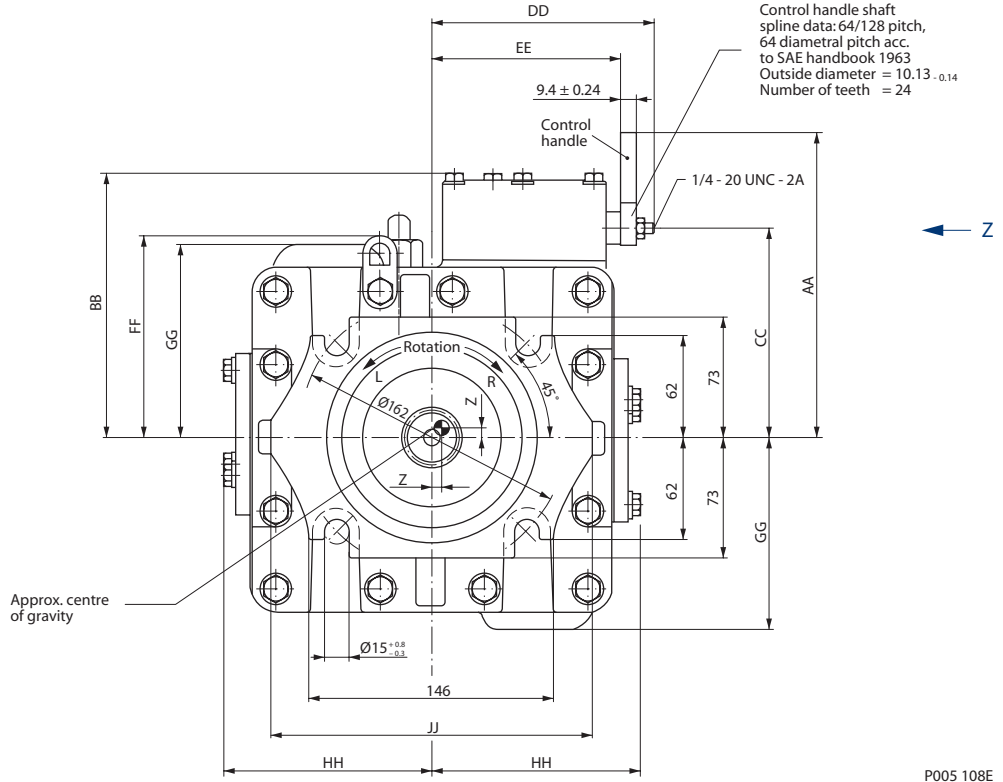

P005 108E

View X (for SPV 2/033 - 2/052 only)

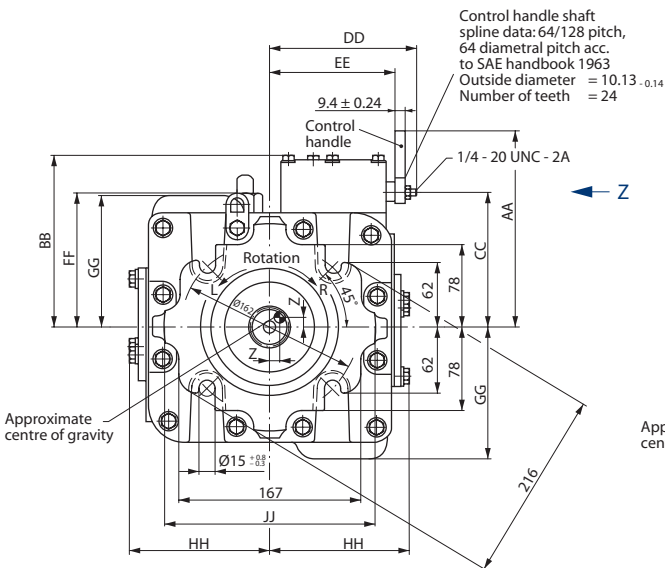

View X (for SPV 2/033 - 2/052 only)

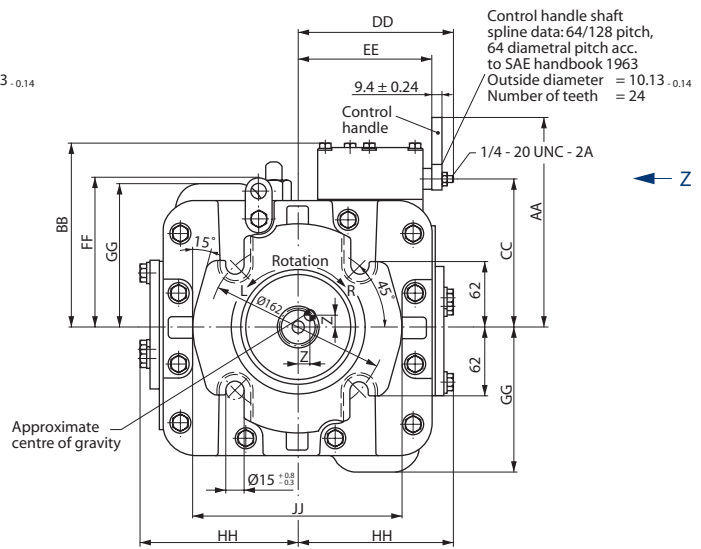

P005 108E

OUTLINE DRAWING, CONFIGURATION PS, DISPLACEMENT CONTROL VML 1 (Continued)

Dimensions												
Frame size	B mm [in]	C mm [in]	D mm [in]	E mm [in]	F mm [in]	G mm [in]	H mm [in]	J mm [in]	K mm [in]	L mm [in]	M mm [in]	Ø N mm [in]
033	284 [11.181]	263 [10.354]	270 [10.630]	225 [8.858]	162 [6.378]	159 [6.260]	100 [3.937]	94 [3.701]	58 [2.283]	48 [1.890]	16 [0.630]	84 [3.307]
052	301 [11.850]	280 [11.024]	282 [11.102]	246 [9.685]	174 [6.850]	152 [5.984]	107 [4.213]	106 [4.173]	70 [2.756]	48 [1.890]	16 [0.630]	84 [3.307]
070	315 [12.402]	294 [11.575]	305 [12.008]	259 [10.197]	188 [7.402]	146 [5.748]	112 [4.409]	120 [4.724]	84 [3.307]	48 [1.890]	16 [0.630]	84 [3.307]
089	328 [12.913]	307 [12.087]	312 [12.283]	271 [10.669]	195 [7.677]	140 [5.512]	118 [4.646]	129 [5.079]	91 [3.583]	49 [1.929]	17.5 [0.689]	98 [3.858]
Frame size	T mm [in]	U mm [in]	V mm [in]	W mm [in]	X mm [in]	Y mm [in]	Z mm [in]	AA mm [in]	BB mm [in]	CC mm [in]	DD mm [in]	EE mm [in]
033	62 [2.441]	95.7 [3.768]	92 [3.622]	95 [3.740]	51 [2.008]	81 [3.189]	3 [0.118]	174.9 [6.886]	150 [5.906]	115.9 [4.563]	120 [4.724]	100 [3.937]
052	68 [2.677]	108.7 [4.280]	102 [4.016]	108 [4.252]	53.2 [2.094]	85.8 [3.378]	6.35 [0.250]	187.6 [7.386]	162 [6.378]	128.6 [5.063]	131 [5.157]	110 [4.331]
070	71.4 [2.811]	112.7 [4.437]	105 [4.134]	108 [4.252]	60.5 [2.382]	85.8 [3.378]	9.5 [0.374]	187.6 [7.386]	162 [6.378]	128.6 [5.063]	133 [5.236]	113 [4.449]
089	77.7 [3.059]	128.7 [5.067]	115 [4.528]	119 [4.685]	65 [2.559]	95.2 [3.748]	12.7 [0.500]	198.6 [7.819]	173 [6.811]	139.6 [5.496]	144 [5.669]	123 [4.843]
Frame size	FF mm [in]	GG mm [in]	HH mm [in]	JJ mm [in]	A ¹ mm [in]		Shaft spline				Bore diameter for shaft coupling mm [in]	
					Charge pump cm ³ [in ³]		Ø O mm [in]	Ø P mm [in]	R mm [in]	S		
					12 [0.732]	18 [1.098]						
033	117 [4.606]	113 [4.449]	108 [4.252]	190 [7.480]	341 [13.425]	350 [13.780]	34.50 ^{-0.17} _{-0.0067} [1.358]	33.338 [1.313]	21 [0.827]	16/32	31.75 ^{+0.062} _[1.250 + 0.0024]	
052	122 [4.803]	116 [4.567]	124 [4.882]	191 [7.520]	358 [14.094]	367 [14.449]	34.50 ^{-0.17} _{-0.0067} [1.358]	33.338 [1.313]	21 [0.827]	16/32	31.75 ^{+0.062} _[1.250 + 0.0024]	
070	126 [4.961]	123 [4.843]	130 [5.118]	194 [7.638]	372 [14.646]	381 [15.000]	34.50 ^{-0.17} _{-0.0067} [1.358]	33.338 [1.313]	21 [0.827]	16/32	31.75 ^{+0.062} _[1.250 + 0.0024]	
089	140 [5.512]	134 [5.276]	148 [5.827]	194 [7.638]	358 [14.094]	394 [15.512]	37.68 ^{-0.17} _{-0.0067} [1.483]	36.513 [1.438]	23 [0.906]	16/32	34.95 ^{+0.062} _[1.376 + 0.0024]	

¹ Short version available on request. Please contact your local Sauer-Danfoss representative.

TAPERED SHAFT END

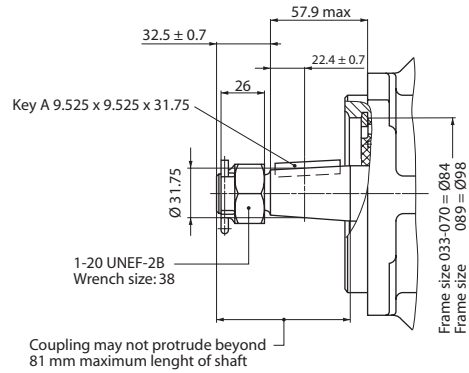

P000 006E

Depth, keygroove: 5,7 + 0,1
Shaft, cone: 1 : 8

**PUMP CONFIGURATION
AA 010, DISPLACEMENT
CONTROL VML 1**

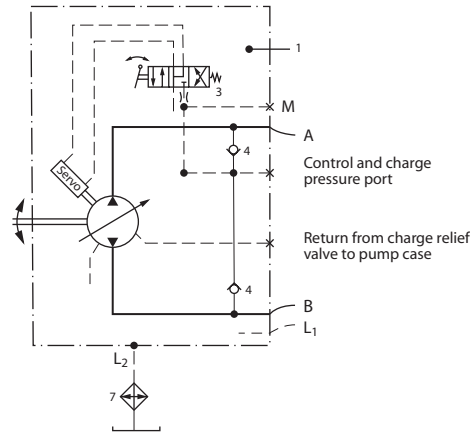

P000 058E

Designation:

- 1 = Variable Displacement pump
- 3 = Servo control valve
- 4 = Charge check valve
- 7 = Heat exchanger

Ports:

- A, B = Main pressure ports (working loop)
- L1, L2 = Drain ports
- M = Gauge port - charge pressure

PUMP CONFIGURATION AA 010, DISPLACEMENT CONTROL VML 1 (continued)

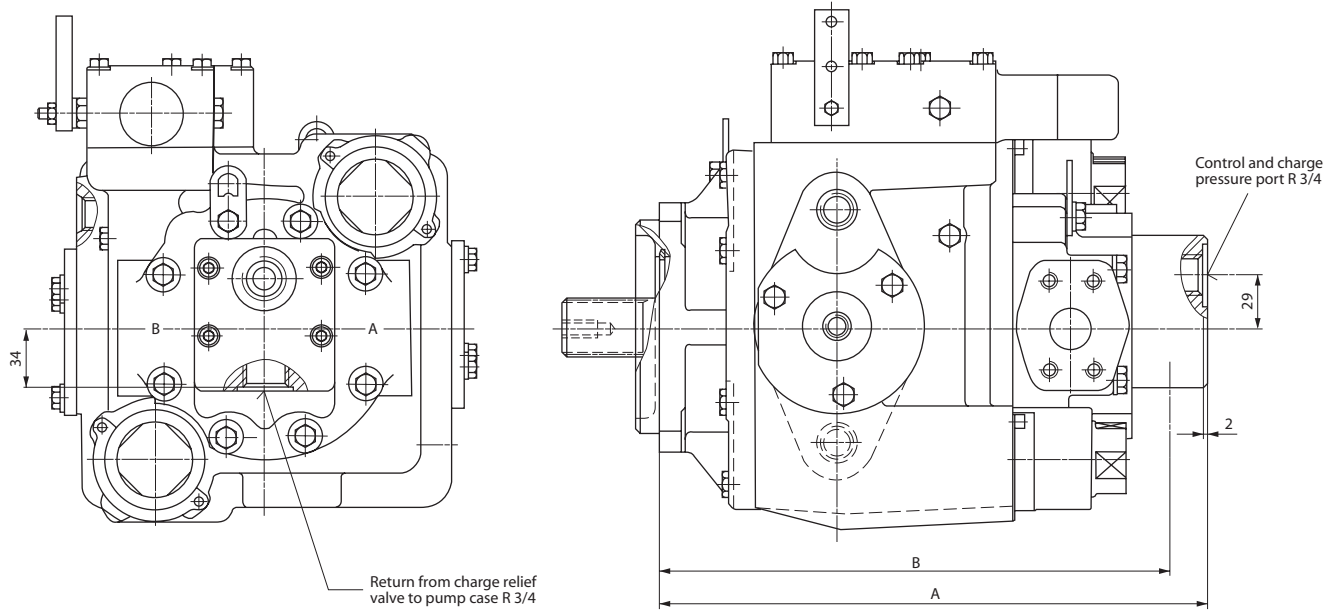

P000 009E

Dimensions			
Frame Size	A mm [in]	B mm [in]	Weight kg [lb]
033	308 [12.126]	285 [11.220]	46 [101]
052	324 [12.756]	301 [11.850]	56 [123]
070	339 [13.346]	316 [12.441]	63.5 [140]
089	352 [13.858]	329 [12.953]	78.5 [173]

OUTLINE DRAWING, CONFIGURATION PS, DISPLACEMENT CONTROL VML 1

- * Minimum and maximum angle α , (see section servo displacement control).
- ** Shaft spline data: spline shaft with involute spline, according to SAE handbook, 1963, class 1, fillet root side fit.

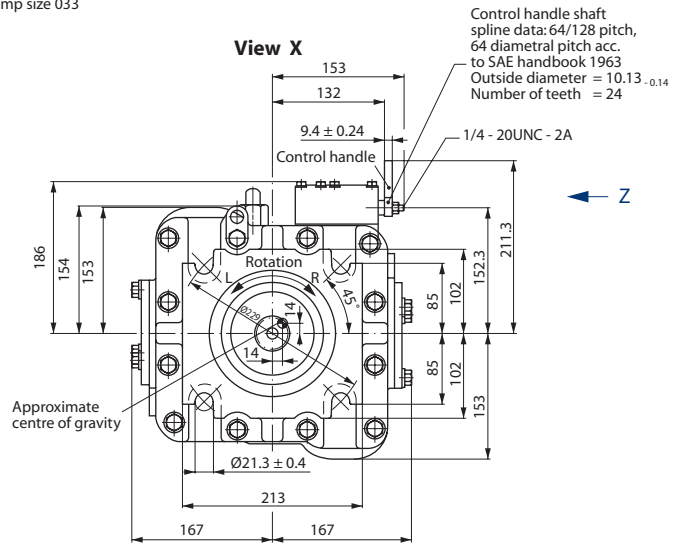
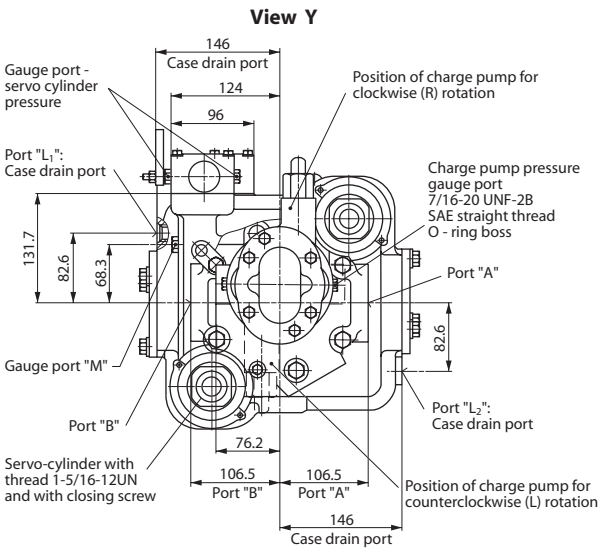
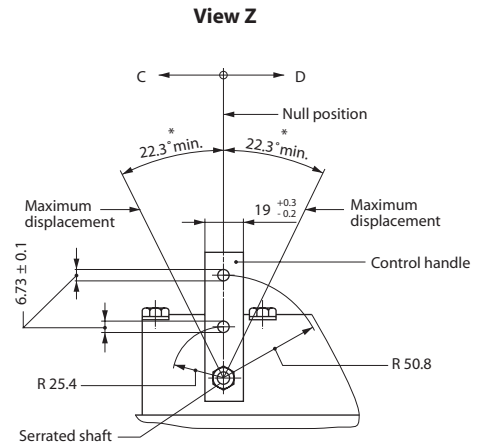
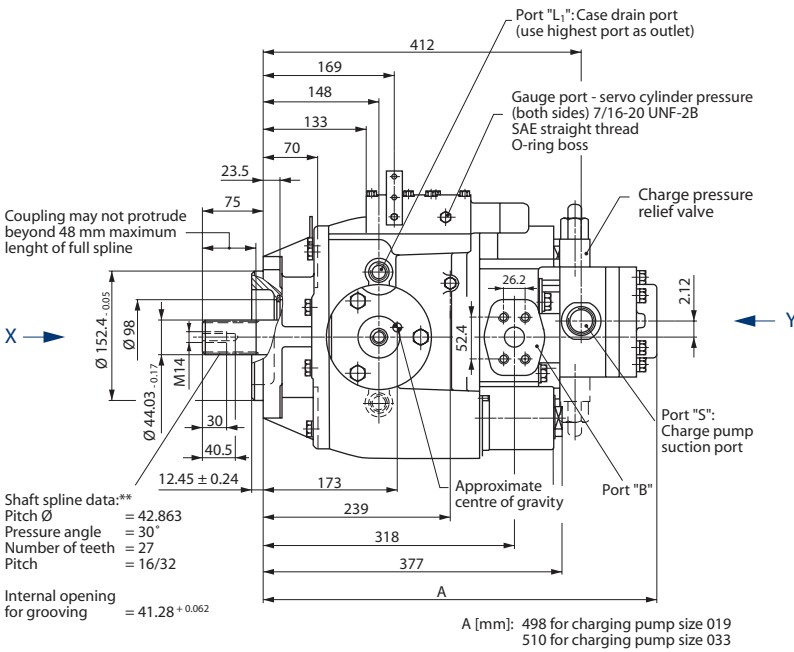

P005 109E

Frame size	Port A and B	Port L ₁ and L ₂	Port S	Port M
119	SAE flange, size 1 SAE split flange boss 5000 psi 4 threads 3/8-16 UNC-2B 18 deep	7/8-14 UNF-2B SAE straight thread O-ring boss	1 5/16-12 UNF-2B SAE straight thread O-ring boss	7/16-20 UNF-2B SAE straight thread O-ring boss

OUTLINE DRAWING, CONFIGURATION PS, DISPLACEMENT CONTROL VML 1

* Minimum and maximum angle α , (see section servo displacement control).

** Shaft spline data: spline shaft with involute spline, according to SAE handbook, 1963, class 1, fillet root side fit.

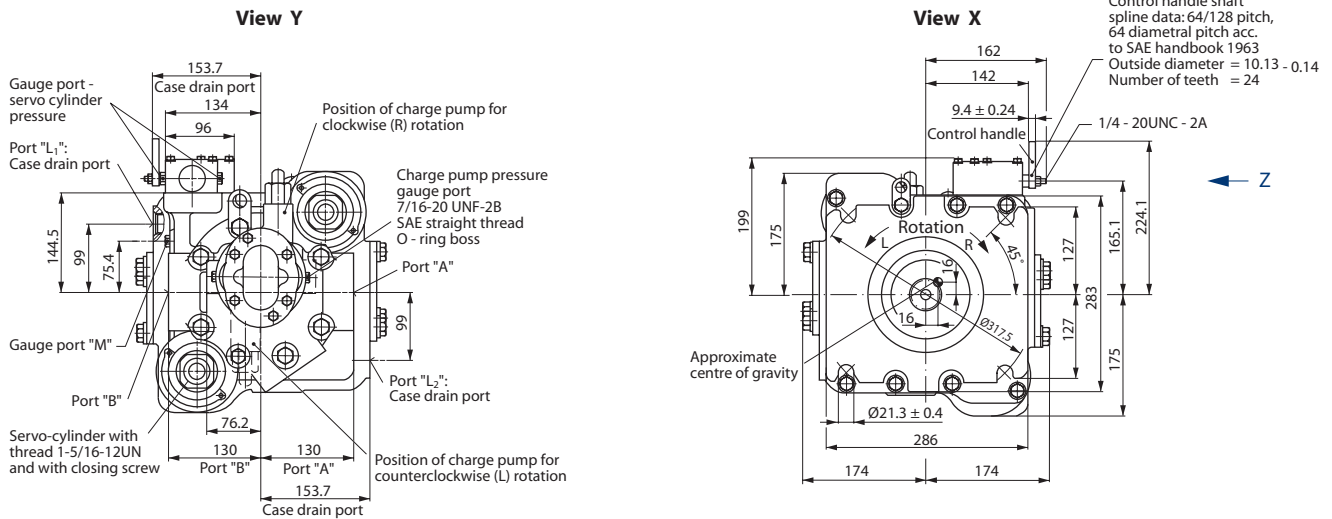
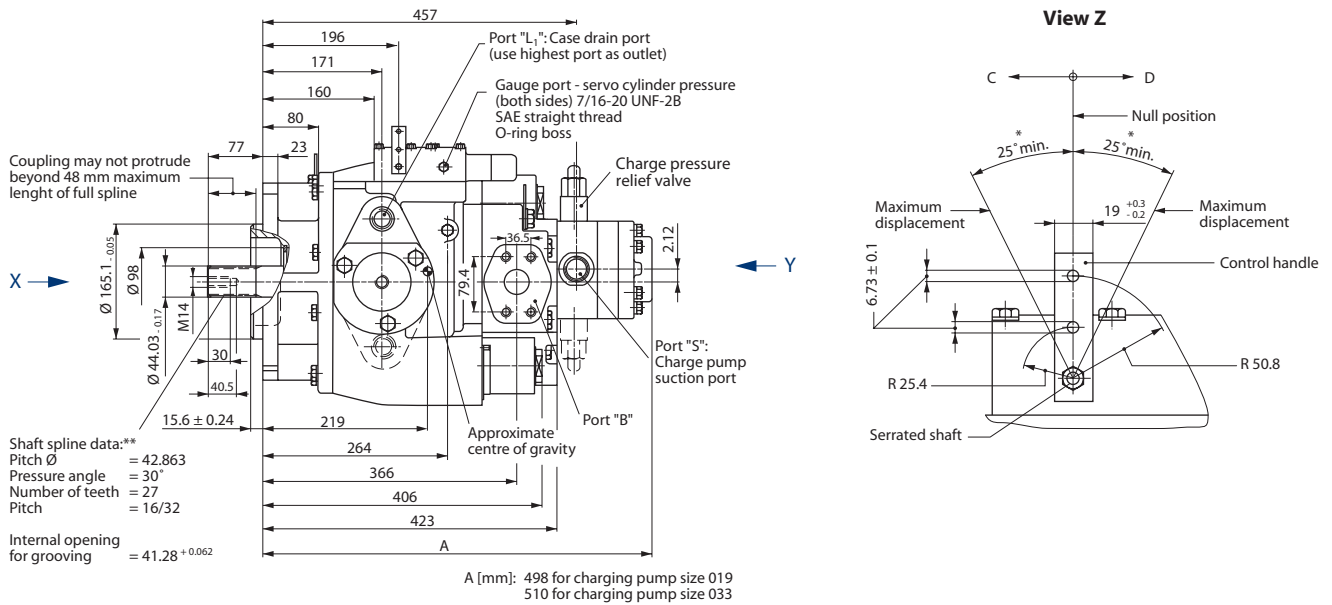

P005 110E

Frame size	Port A and B	Port L ₁ and L ₂	Port S	Port M
166	SAE flange, size 1 1/2 SAE split flange boss 6000 psi 4 threads 5/8-11 UNC-2B 35 deep	1 5/16-12 UNF-2B SAE straight thread O-ring boss	1 5/16-12 UNF-2B SAE straight thread O-ring boss	7/16-20 UNF-2B SAE straight thread O-ring boss

OUTLINE DRAWING, CONFIGURATION PS, DISPLACEMENT CONTROL VML 1

- * Minimum and maximum angle α , (see section servo displacement control).
- ** Shaft spline data: spline shaft with involute spline, according to SAE handbook, 1963, class 1, fillet root side fit.

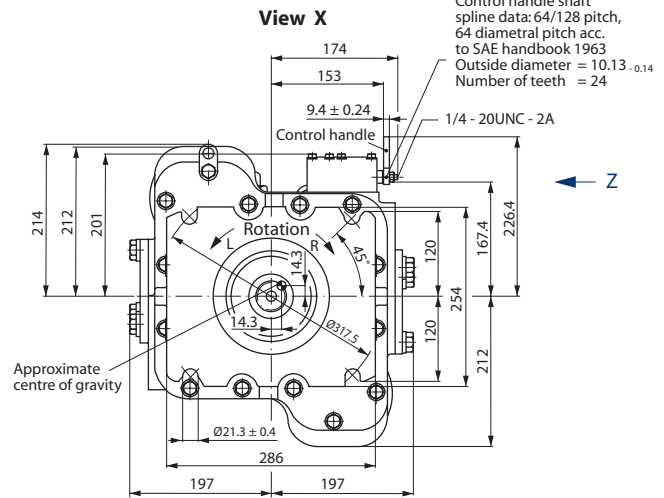
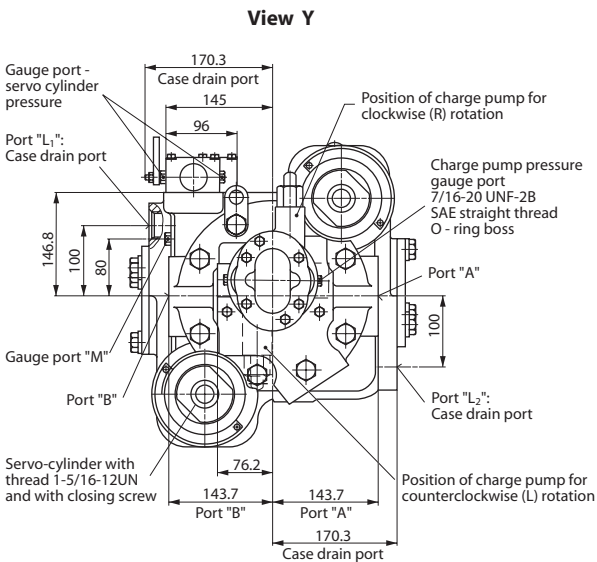
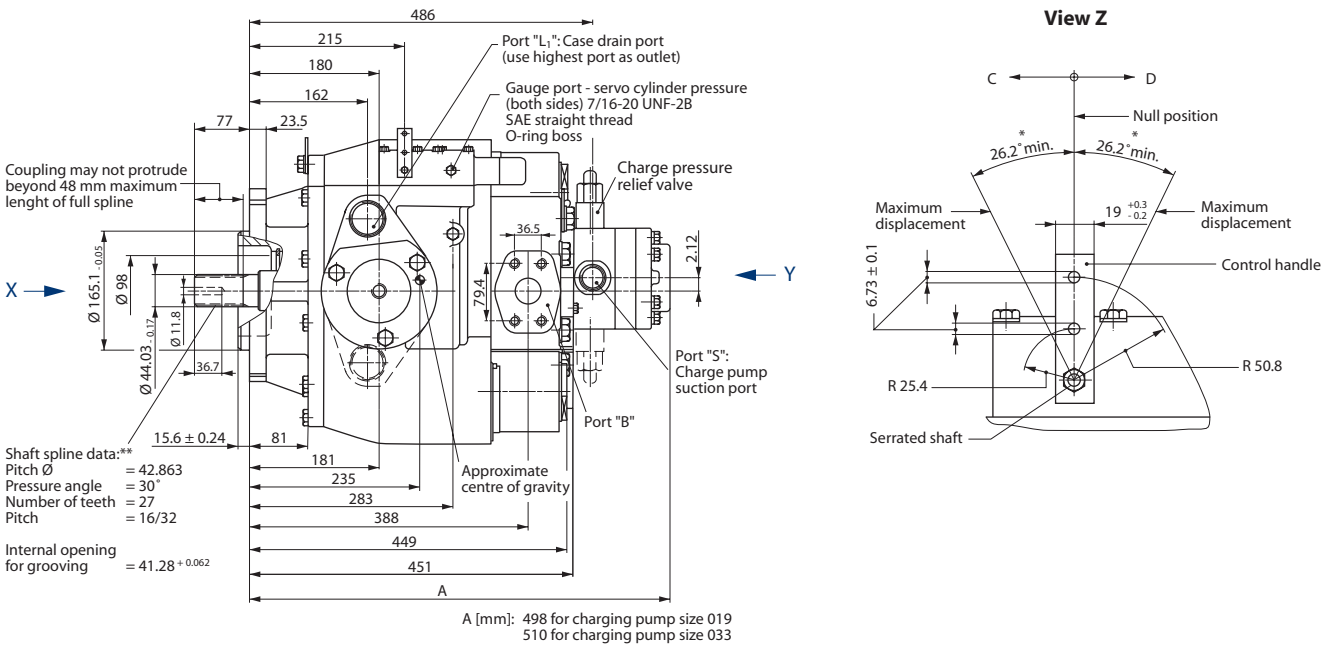

P005 111E

Frame size	Port A and B	Port L ₁ and L ₂	Port S	Port M
227	SAE flange, size 1 1/2 SAE split flange boss 6000 psi 4 threads 5/8-14 UNC-2B 35 deep	1 7/8-12 UNF-2B SAE straight thread O-ring boss	1 5/16-12 UNF-2B SAE straight thread O-ring boss	7/16-20 UNF-2B SAE straight thread O-ring boss

**PUMP CONFIGURATION
PS, DISPLACEMENT
CONTROL VML 1**

- * Minimum and maximum angle α , (see section servo displacement control).
- ** Shaft spline data: spline shaft with involute spline, according to SAE handbook, 1963, class 1, fillet root side fit.

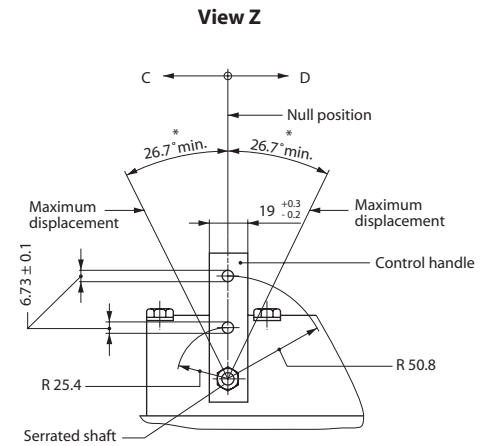

P000 026E

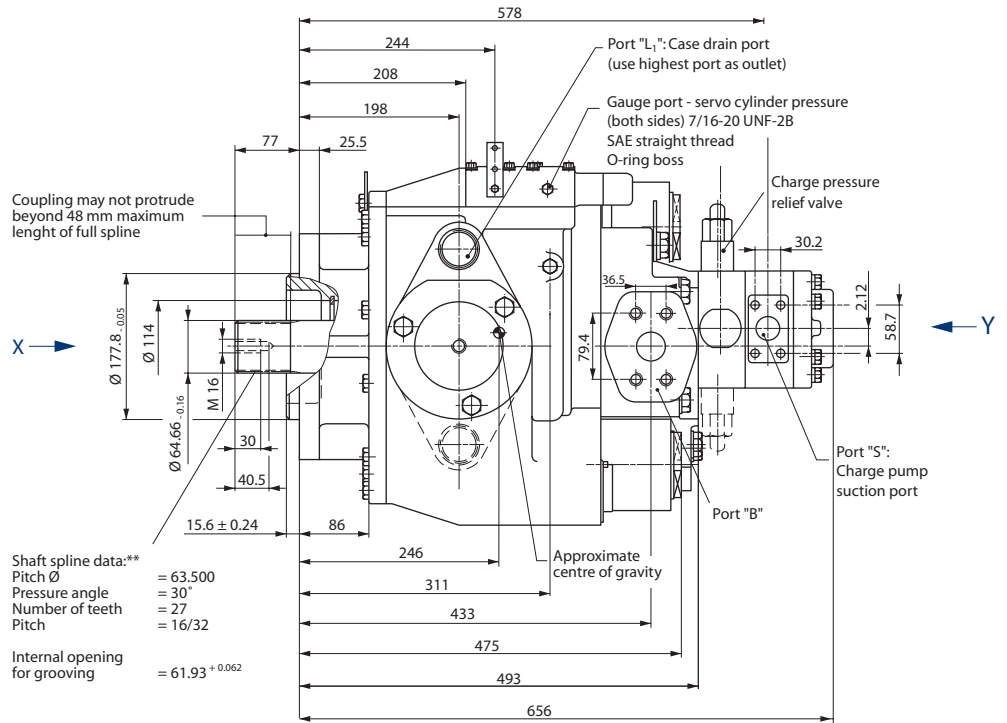

P005 115E

PUMP CONFIGURATION PS, DISPLACEMENT CONTROL VML 1 (continued)

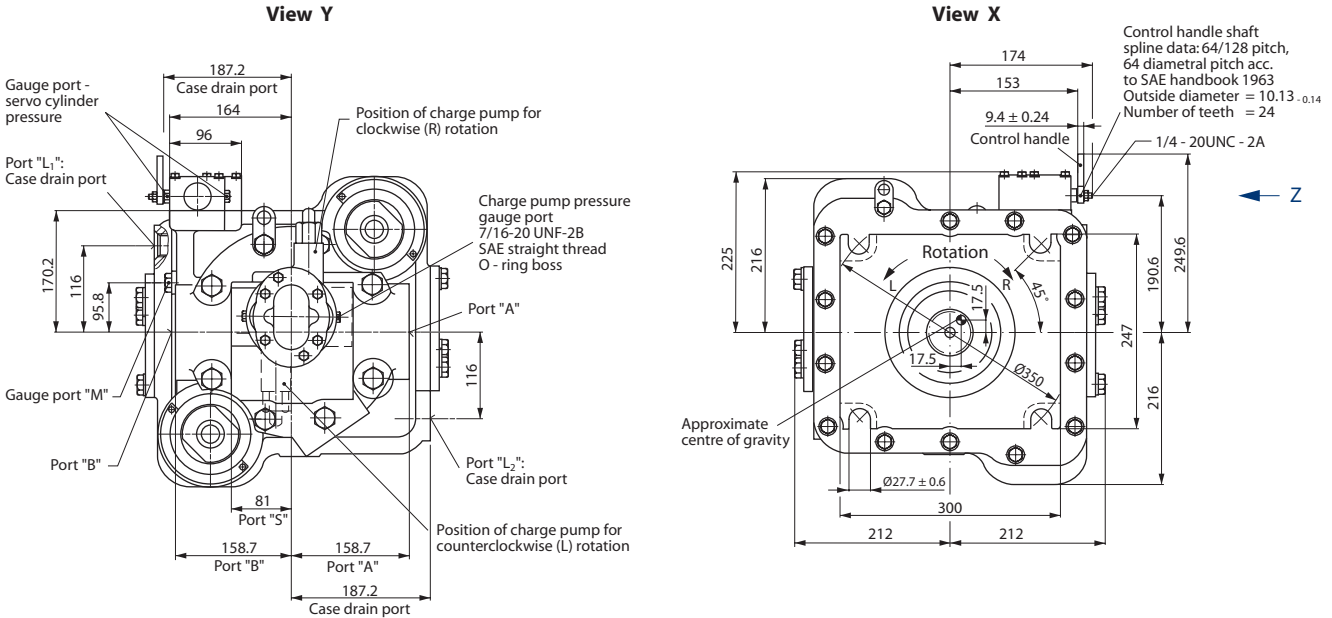

P005 111E

Frame size	Port A and B	Port L ₁ and L ₂	Port S	Port M
334	SAE flange, size 1 1/2 SAE split flange boss 6000 psi 4 threads 5/8-11 UNC-2B 35 deep	1 7/8-12 UNF-2B SAE straight thread O-ring boss	SAE flange, size 1 1/4 SAE split flange boss 3000 psi 4 threads 7/16-14 UNC-2B 28 deep	7/16-20 UNF-2B SAE straight thread O-ring boss

**PUMP CONFIGURATION
AA 010, DISPLACEMENT
CONTROL VML 1**

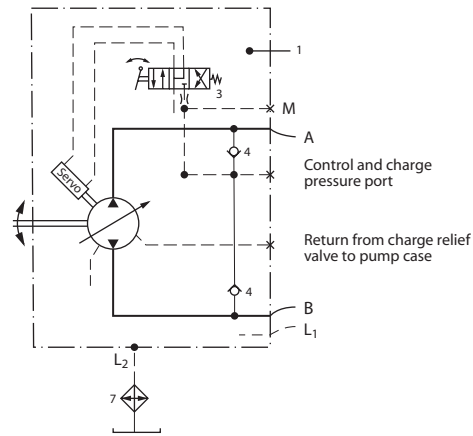

Designation:

- 1 = Variable Displacement pump
- 3 = Servo control valve
- 4 = Charge check valve
- 7 = Heat exchanger

Ports:

- A, B = Main pressure ports (working loop)
- S = Suction port - charge pump
- L1, L2 = Drain ports
- M = Gauge port - charge pressure

P000 058E

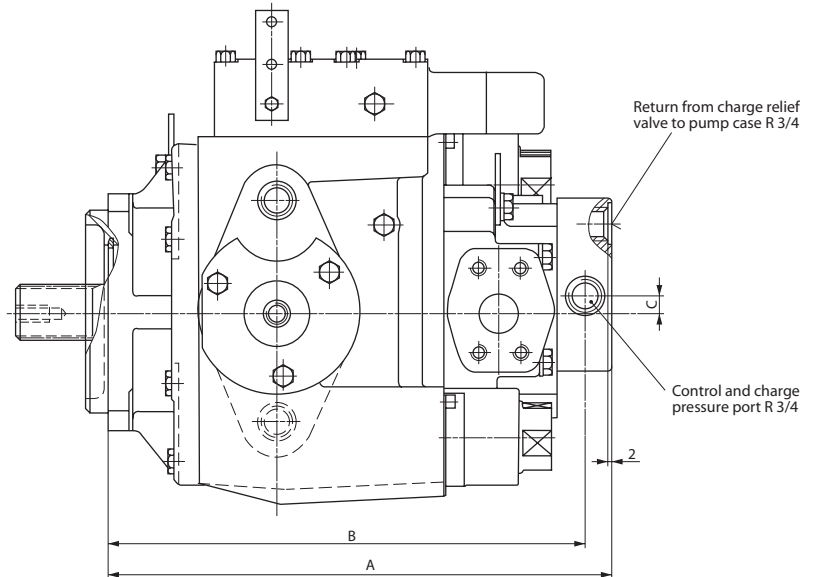
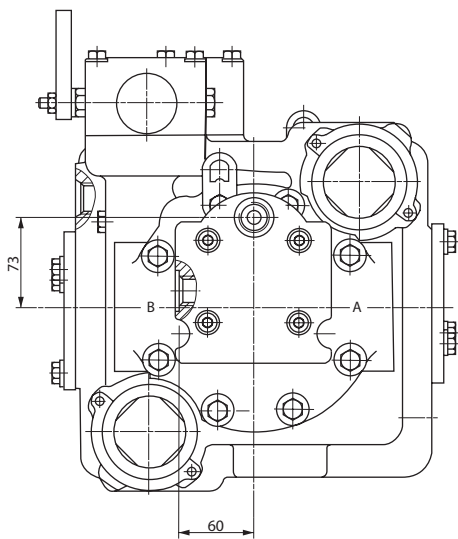

P000 010E

Dimensions				
Frame size	A mm [in]	B mm [in]	C mm [in]	Weight kg [lb]
119	422 [16.614]	401 [15.787]	14 [0.551]	128.5 [283]
166	476 [18.740]	450 [17.717]		160 [353]
227	504 [19.842]	478 [18.819]		208 [459]
334	546 [21.496]	520 [20.472]	21 [0.827]	264.5 [583]



OUR PRODUCTS

Hydrostatic transmissions
Hydraulic power steering
Electric power steering
Closed and open circuit axial piston pumps and motors
Gear pumps and motors
Bent axis motors
Radial piston motors
Orbital motors
Transit mixer drives
Planetary compact gears
Proportional valves
Directional spool valves
Cartridge valves
Hydraulic integrated circuits
Hydrostatic transaxles
Integrated systems
Fan drive systems
Electrohydraulic controls
Digital electronics and software
Battery powered inverter
Sensors

Sauer-Danfoss Hydraulic Power Systems – Market Leaders Worldwide

Sauer-Danfoss is a comprehensive supplier providing complete systems to the global mobile market.

Sauer-Danfoss serves markets such as agriculture, construction, road building, material handling, municipal, forestry, turf care, and many others.

We offer our customers optimum solutions for their needs and develop new products and systems in close cooperation and partnership with them.

Sauer-Danfoss specializes in integrating a full range of system components to provide vehicle designers with the most advanced total system design.

Sauer-Danfoss provides comprehensive worldwide service for its products through an extensive network of Authorized Service Centers strategically located in all parts of the world.

SAMT Hydraulics
Factory 19, 5 Lyn Parade
Prestons, NSW 2170 AUSTRALIA
Phone: (02) 9607 4100, Fax: (02) 9607 4200

Sauer-Danfoss (US) Company
2800 East 13th Street
Ames, IA 50010, USA
Phone: +1 515 239-6000, Fax: +1 515 239 6618

Sauer-Danfoss (Neumünster) GmbH & Co. OHG
Postfach 2460, D-24531 Neumünster
Krokamp 35, D-24539 Neumünster, Germany
Phone +49 4321 871-0, Fax: +49 4321 871 122

Sauer-Danfoss (Nordborg) A/S
DK-6430 Nordborg, Denmark
Phone: +45 7488 4444, Fax: +45 7488 4400