

Standard Pumps - UNIVERSAL ONLY

PUMP RATINGS

CAPACITY cc/rev	0,8	1,2	1,6	2,0	2,5	3,1	4,0	5,0	6,3	8,0
Max Cont. Pressure (Bar)	250	250	250	250	250	250	200	160	125	100
Max. Int. Pressure (Bar)	250	250	250	250	250	250	250	220	170	140

Pumps can be combined to give hi – lo two stage pumps

TWO STAGE PUMPS

Many applications, such as waste compactors, presses and swaging machines, require minimal pressure and high flow during the initial stage of operation and high pressure with low flow in the second stage.

Two pumps can be economically and easily combined to meet these requirements. Two stage pumps reduce the run time and power required and can result in considerable cost savings to the user.

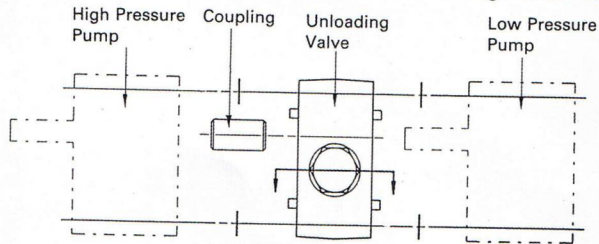

HYDRAULIC CIRCUIT

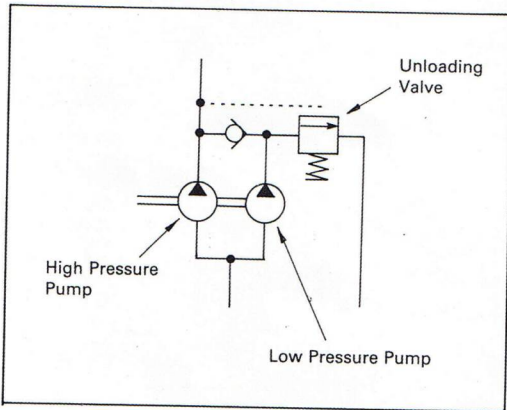

TYPICAL FLOW CURVE

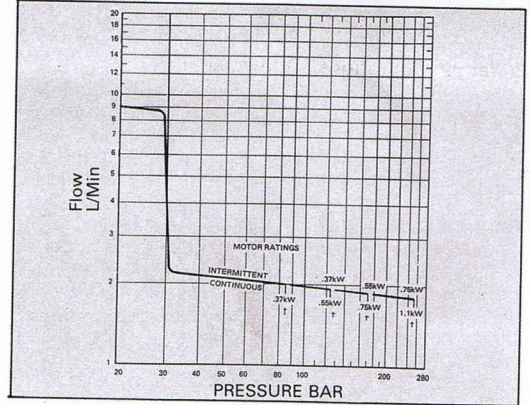

Flow Dividers

Flow dividers are available in standard ranges
0 – 25 L/Min and 0 – 50 L/Min.
Dimensions below show 0 – 25 L/Min unit.

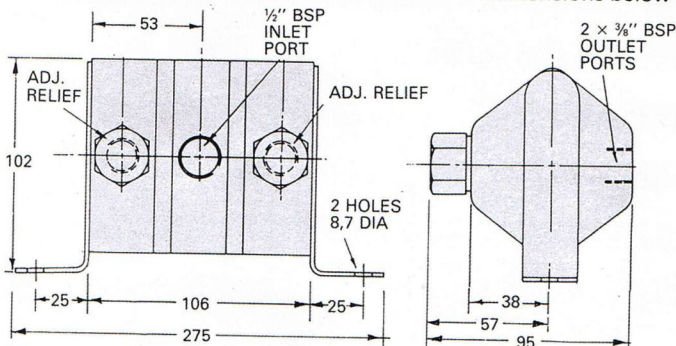

CIRCUIT DIAGRAM

