

Size 50 to 11,600 cc/rev, up to 250 bar, 36,000Nm, 240kW	Fixed Displacement Radial Piston Hydraulic Motor Staffa, Series B	Data Sheet M-1001/03.00 GB
--	---	----------------------------

Features

- ◇ Rugged, reliable, proven design.
- ◇ Unique Hydrostatic balancing provides minimum wear and extended life.
- ◇ High volumetric and mechanical efficiency.
- ◇ Capacities range from 50 to 11600 cc per rev.
- ◇ Large variety of Shaft and Porting options.
- ◇ Output torque up to 36000 Nm.
- ◇ Wide range of mounting interfaces available.
- ◇ Highly accurate electronic positional and velocity control systems also available.

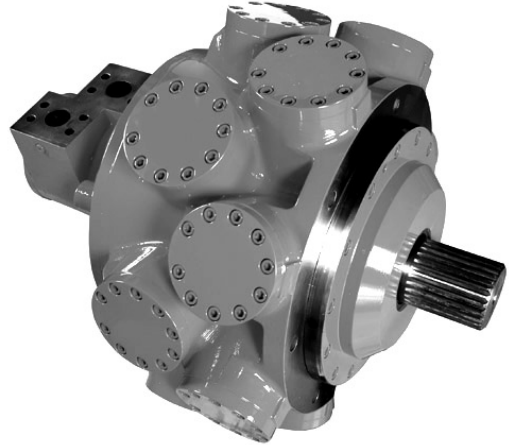

Description

The Kawasaki “Staffa” range of high torque low speed fixed displacement radial piston hydraulic motors consists of 13 frame sizes ranging from the HMB010 to HMB700. Capacity ranges from 50 to 11,600cc/rev.

The rugged, well proven design incorporates high efficiency, combined with good breakout torque and smooth running capability.

Various features and options are available including, on request, mountings to match competitors’ interfaces.

The Kawasaki “Staffa” range also includes dual and continuously variable displacement motors. To obtain details of this product range please refer to data sheet M-1002

Model Staffa B	Page 1.70	Data Sheet M-1001/03.00	
----------------	-----------	-------------------------	---

Ordering Code – Staffa Motor Series B

F11 – HM*B – 060 – S3 – FM3 – Tx – * – PL**

Fluid Type
 Blank: Mineral oil.
 F3: Phosphate ester (HFD fluid).
 F11: Water-based fluids (HFA, HFB & HFC)
 * : Consult

Model Type
 Blank: Standard (HMB)
 HD: Heavy duty (HMHDB)

Frame Size
 (See options page 7)

Shaft Type
 See shaft type option list on Page 3

Main Port Connections
 See Port Connection details on Page 4

Special Features
 PL **: Non-catalogued features, (**)= number assigned as required.
 eg:
 Stainless steel shaft sleeves.
 Alternative port connections.
 Shaft variants.
 Alternative displacement.
 Special mountings.
 Special paint.

Design Series Number

Tacho/Encoder Drive
 Blank: None
 T: Staffa original tacho drive.
 Tx: Customer specific encoder drive.



Shaft Options

MOTOR TYPE

SHAFT DESCRIPTION

HMB010	P*	=	Parallel keyed shaft Ø 40mm
HMB010	S*	=	Involute spline 13 teeth BS3550
HMB030/045	(H)S*	=	Involute spline 17 teeth to BS3550
HMB030/045	(H)P	=	Parallel keyed shaft Ø 55mm
HMB030/045	(H)Z*	=	Involute spline to DIN5480 (W55x3x17x7h)
HMB045	Q*	=	Internal involute spline 21 teeth to BS3550
HMB060/080/100	(H)P*	=	Parallel keyed shaft Ø 60mm
HMB060/080/100	(H)S*	=	Involute spline 14 teeth to BS3550
HMB060/080/100	(H)Z*	=	Involute spline to DIN5480 (W70x3x22x7h)
HMB060/080/100	(H)Q*	=	Internal involute spline 24 teeth to BS3550
HMB060/080/100/125/150/200/ HMB270/325	T*	=	Long tapered keyed shaft
HMB060/080/100/270/325	X*	=	Short tapered keyed shaft
HMB125/150/200/270/325	(H)P1*	=	Parallel keyed shaft Ø 85mm
HMHDB125/150/200/270 & 325	(H)P2*	=	Parallel keyed shaft Ø 100mm
HMB125/150/200/270/325	(H)S3*	=	Involute spline 20 teeth to BS3550
HMB125/150/200	(H)S4*	=	Involute spline 16 teeth at 20°
HMHDB125/150/200, 270/325	(H)S5*	=	Involute spline 23 teeth to BS3550
HMB125/150/200	(H)Z3*	=	Involute spline to DIN5480 (W85x3x27x7h)
HMHDB125/150/200	(H)Z5*	=	Involute spline to DIN5480 (W100x4x24x7h)
HMHDB125/150/200/270/325	(H)Q*	=	Internal involute spline 34 teeth to BS3550
HMHDB125/150/200/270/325	(H)X*	=	Short taper, keyed shaft
HMB270/325 + HMHDB270/325	(H)Z*	=	Involute spline to DIN5480 (W100x4x24x7h)
HMHDB400	P*	=	Parallel shaft with two keys Ø 100mm
HMHDB400	S*	=	Involute spline 23 teeth to BS3550
HMHDB400	Z*	=	Involute spline to DIN5480 (W100x4x24x7h)
HMHDB400	Q*	=	Internal involute spline 31 teeth to BS3550
HMHDB400	X*	=	Tapered keyed shaft
HMB700	Z*	=	Involute spline to DIN5480 (W120x4x28x7h)
HMB700	P	=	Parallel keyed shaft at 120° 120 Ø

Notes:

* - For installations where shaft is vertically upwards specify "V" after shaft type letter to ensure that additional high level drain port is provided.

(H) - Use "H" prefix code as noted to specify "hollow" shaft with through hole Ø 26.2. Hollow shafts are available only with type "S04" main port connection.

For all shaft dimensions see the motor installation drawings



Model
Staffa B

Page
3.70

Data Sheet
M-1001/03.00

Main Port Connections**Product Type****HMB010**

Blank = Two, four bolt flange ports of 20mm Ø

HMB030 Mono bloc

Blank = Rear entry ports G 3/4" (BSPF)
 F = Side port SAE 1" -4 Bolt (UNC) flange
 FM = Side port SAE 1" -4 Bolt (Metric) flange

HMB045 Mono bloc

Blank = Rear entry ports G 1" (BSPF)
 D = Dual entry ports G 1" (BSPF)

HMB030/045 Two part build (TPB)

See detail below

HMB060/080/100

F2 = SAE 1", 4 Bolt (UNC) flanges
 FM2 = SAE 1", 4 Bolt (Metric) flanges
 S03 = 6-Bolt (UNF) flange. (Staffa original valve housing)
 F3 = SAE 1 1/4" 4 Bolt (UNC) flanges
 FM3 = SAE 1 1/4" 4 Bolt (Metric) flanges
 S04 ⁽¹⁾ = 6 Bolt (UNF) flanges. (Staffa original valve housing)

HMB125/150/200 + Heavy Duty Variants Details as above, plus the following:

F4 = SAE 1 1/4" 4 Bolt (UNC) flanges
 FM4 = SAE 1 1/2" 4 Bolt (Metric) flanges

HMB270/325 + Heavy Duty Variants

F4 = SAE 1 1/2" 4 Bolt (UNC) flanges
 FM4 = SAE 1 1/2" 4 Bolt (Metric) flanges
 S04 ⁽¹⁾ = 6 Bolt (UNF) flanges. (Staffa original valve housing)

HMHDB400

Blank = Combined 6-Bolt flange and 4 Bolt SAE connection
 Ports "B" and "C" 6-Bolt UNF flange
 Ports "A" and "C" SAE, 2" 4-Bolt UNF flanges
 S045 = 2 x 6 Bolts (UNF) flanges (2 inlet and 2 outlet ports available)

HMB700

FM = Standard code 62
 SAE 2" 4 Bolt (Metric) flanges

Note:⁽¹⁾

Obligatory for hollow shafts type: HP, HS, HZ or HQ



.Functional Symbols

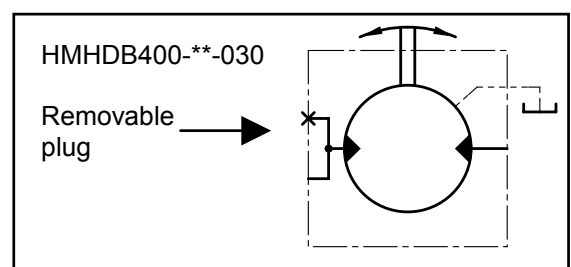
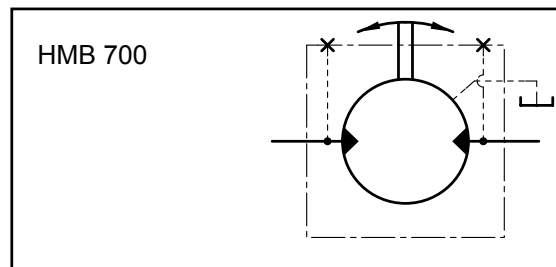
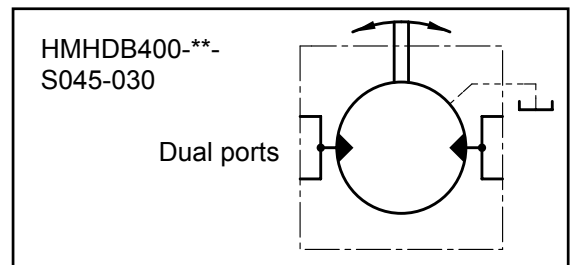
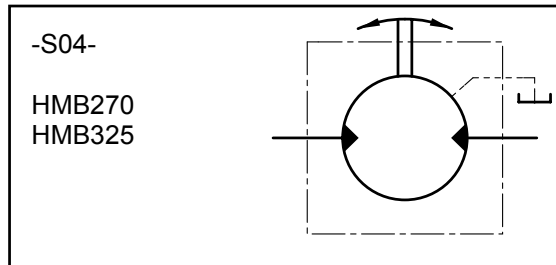
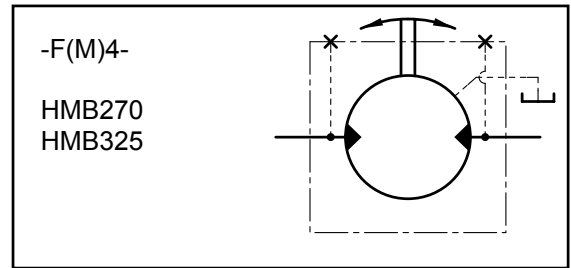
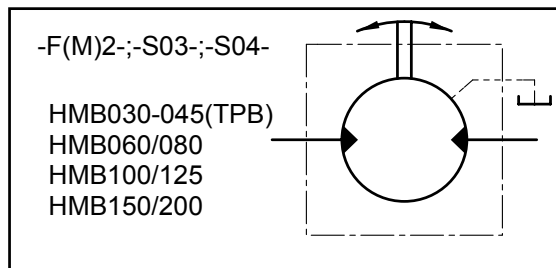
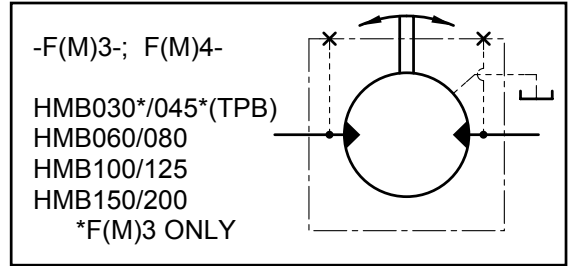
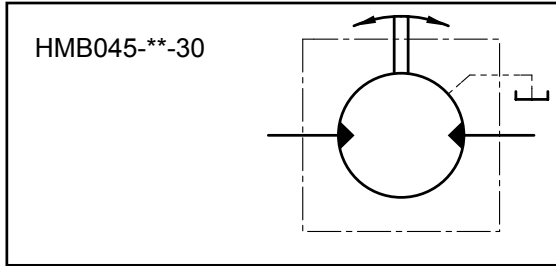
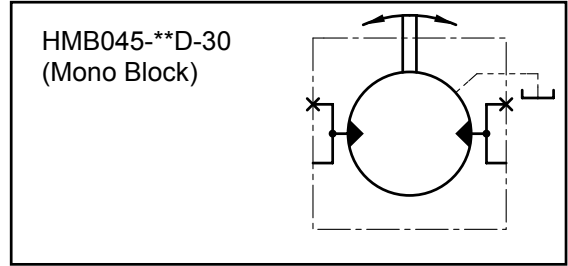
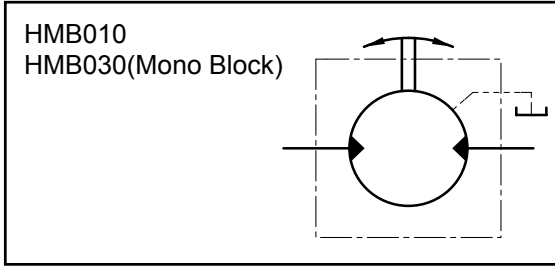

Model Staffa

Page 5.70

Data Sheet M-1001/03.00



Performance Data**Intermittent max pressure**

B010 up to 241 bar

B700 up to 250 bar

All other models to 293 bar.

These pressures are allowable on the following basis:

- (a) Up to 50 r/min: 15% duty for periods up to 5 minutes maximum.
- (b) Over 50 r/min: 2% duty for periods up to 30 seconds maximum.

Continuous rating

For continuous duty the motor must be operating within each of the maximum values for speed, pressure and power.

Intermittent rating

Operation within the intermittent power rating (up to the maximum continuous speed) is permitted on a 15% duty basis, for periods up to 5 minutes maximum .

Limits for fire resistant fluids

Fluid Type	Pressure, bar		Max Speed r/min	Model type
	Continuous	Intermittent		
HFA 5/95% oil in emulsion	103	138	50% of limits for Mineral Oil	All models
HFB 60/40 water in oil emulsion	138	172	As for Mineral Oil	All models
HFC water glycol	103	138	50% of limits or Mineral Oil	All models
HFD phosphate ester	207	241	As for Mineral Oil	B010
	207	293		B030
	250	293		B045 to B400 inc.
	210	250		B700



Performance Data Tables

Motor type	Geometric displacement (cc/rcv)	Average actual running torque (Nm/bar)	Max. continuous speed (rev/min)	Max. continuous output (kW)	Max. continuous pressure. (bar)	Max. intermittent pressure (bar)
B10	188	2.79	500	25	207	241
B030	442	6.56	450	42	207	293
B045	740	10,95	400	60	250	293
B060	983	14.5	300	80	250	293
B060 F2/FM2	983	14.5	200	75	250	293
B080	1344	19.9	300	100	250	293
B080 F2/FM2	1344	19.9	150	77	250	293
B100	1639	24.3	250	110	250	293
B100 F2/FM2	1639	24.3	125	80	250	293
B125	2050	30.66	220	100	250	293
B125 F2/FM2	2050	30.66	100	75	250	293
B150	2470	36.95	220	115	250	293
B150 F3/FM3/S03	2470	36.95	168	115	250	293
B150 F2/FM2	2470	36.95	80	75	250	293
B200	3080	46.07	175	130	250	293
B200 F3/FM3/S03	3080	46.07	135	130	250	293
B200 F2/FM2	3080	46.07	65	75	250	293
B270	4310	63.79	125	140	250	293
B325	5310	79.4	100	140	250	293
B400	6800	101	120	190	250	293
B700	11600	171.7	100	240	210	250

Model
StaffaPage
7.70Data Sheet
M-1001/03.00

Kawasaki
 Hydraulic Products

Non-Standard Displacements

Motor	Displacements cc/rev								
HMB010	177	130	94	50					
HMB030	492	477	455	330	320	300	278	251	213
HMB045	800	700	634	570	500	440			
HMB080	1250	1100	1000						
HMB100	1530	1500							
HMB125	1800								
HMB150	1880	2130							
HMB200	3630*	2870							
HMHDB200	3630*	2785							
HMB270	4588	4500	3688	3600					
HMHDB270	4000								
HMB325	6100*	5187							
HMHDB400	6137	6468	5322	4340	4000	8000*			
HMB700	10600	9600	8850						

Note:

* Reduced pressure and power rating.



Output Torque

These torque curves indicate the maximum output torque and power of a fully run-in motor for a range of pressures and speeds when operating with zero outlet pressure on Mineral Oil of 50 cSt (232 SUS) viscosity. High return line pressures will reduce torque for a given pressure differential. - x - x - x - Upper limit of continuous rating envelope.

B010

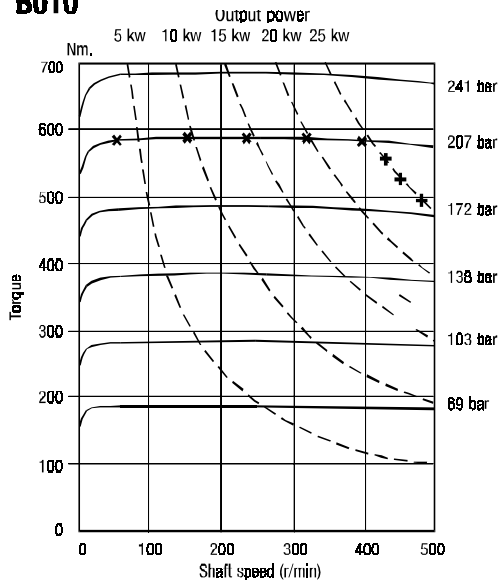

B030

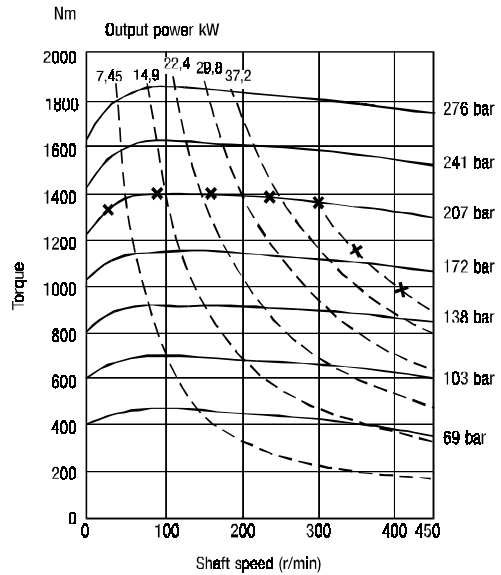

B045

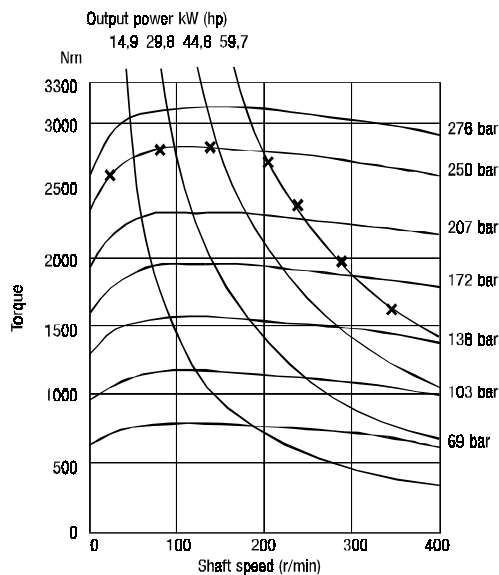

B060

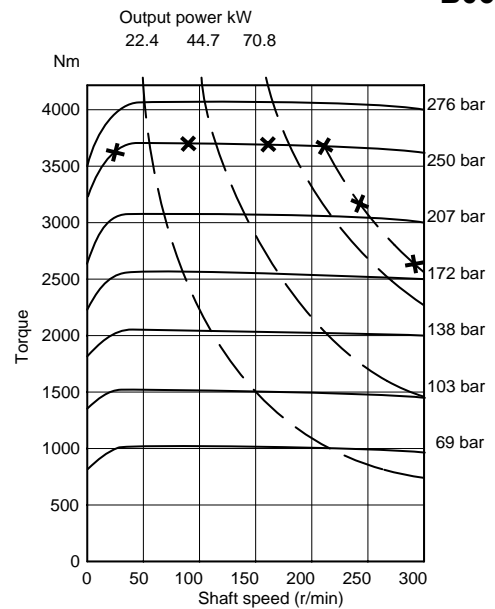

Output Torque (continued)

B080

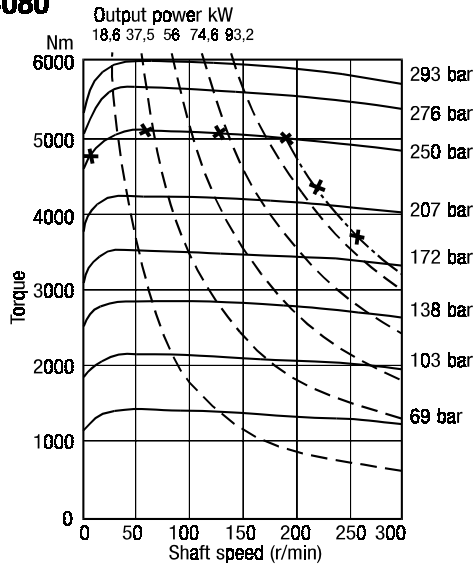

B100

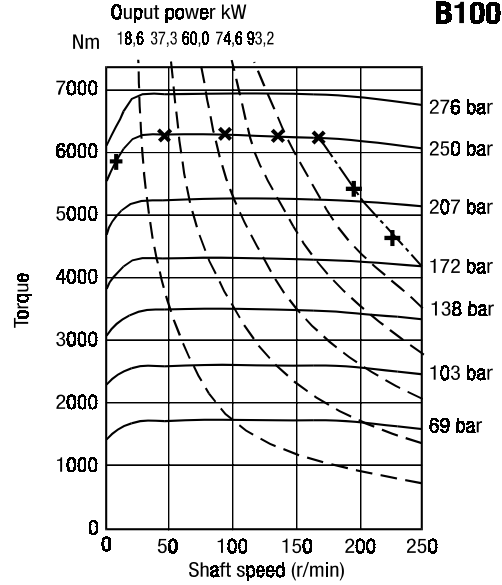

B125

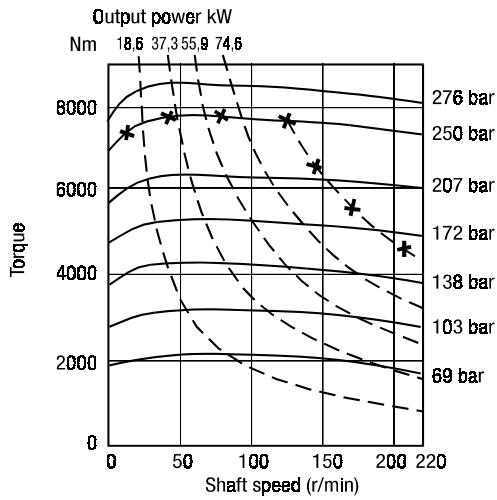

B150

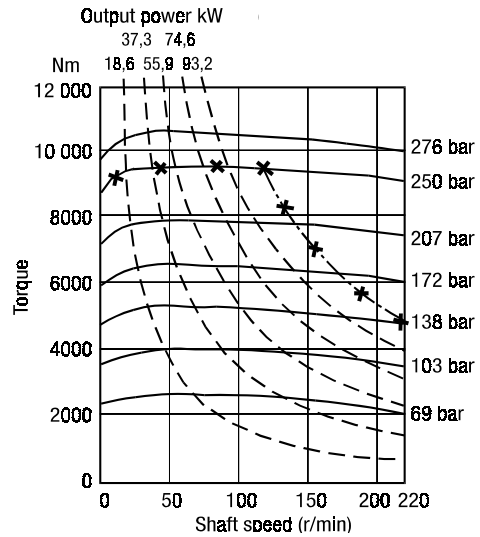

Output Torque (continued)

B200

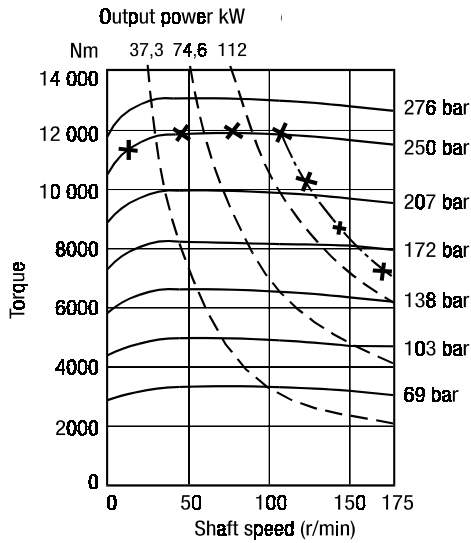

B270

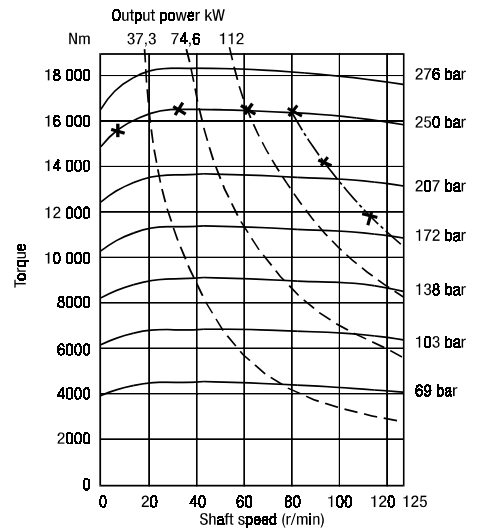

B325

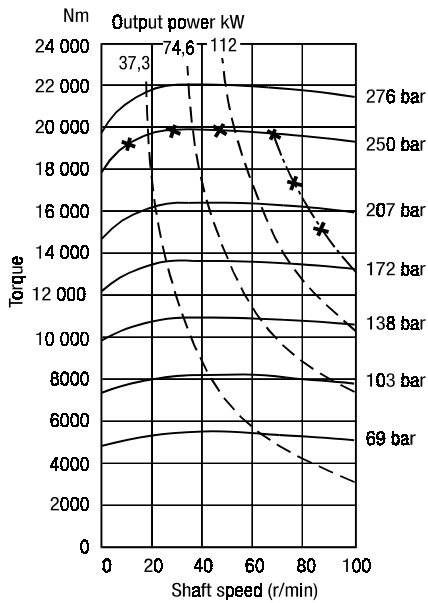

B400

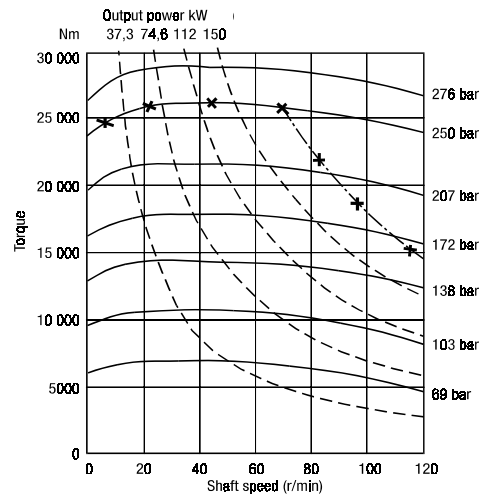

Model
Staffa

Page
11.70

Data Sheet
M-1001/03.00

Output Torque (continued)

B700

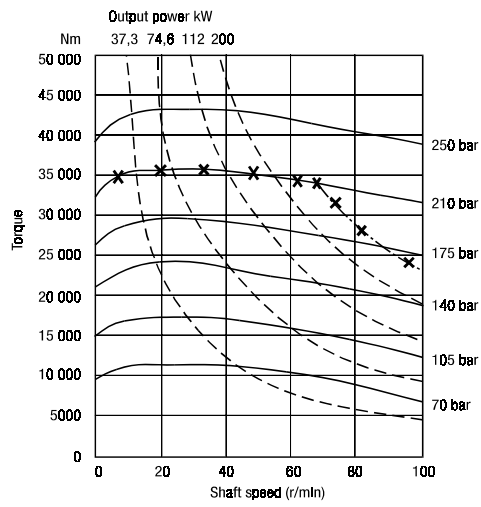

Bearing Life Graphs

HMB 010 Shaft Types P and S

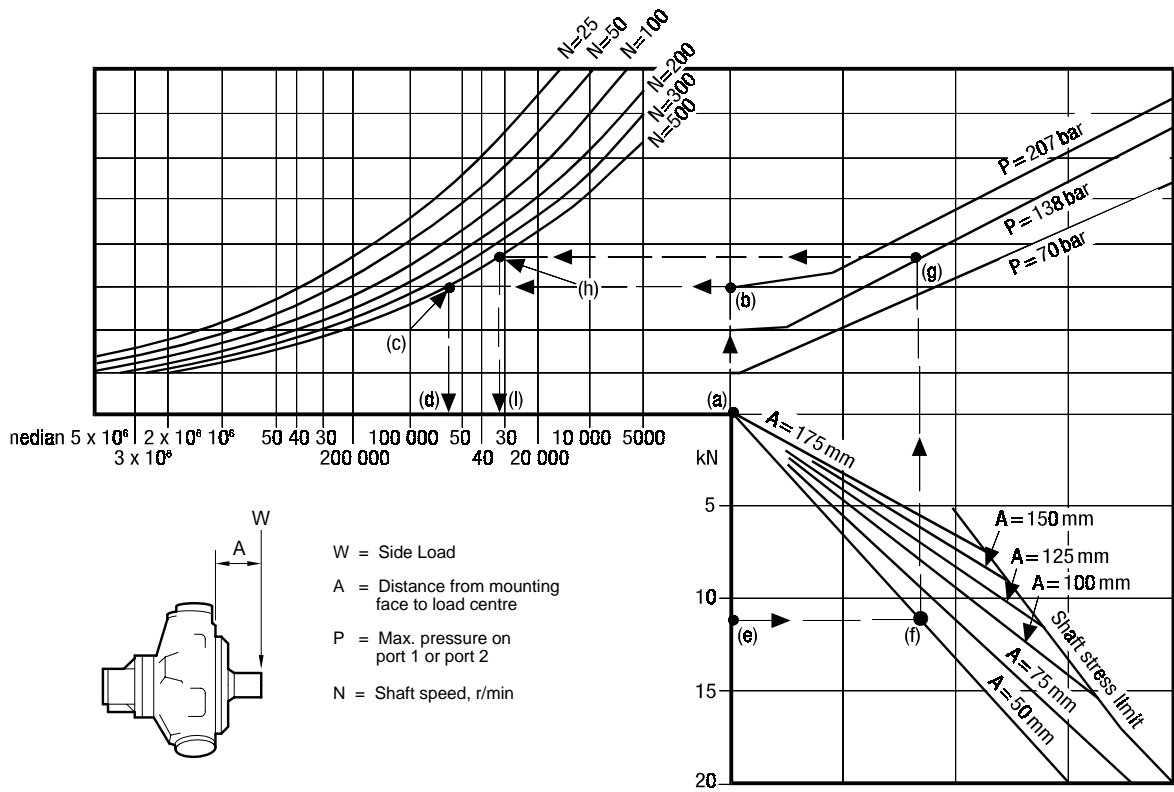

Example 1 (follow chain dotted line):

Side load (W)	(a) 0
System pressure (P)	(b) 207 bar
Speed (N)	(c) 500 r/min.
Median bearing life	(d) 55,000 hrs.
L10 bearing rating = median x 0.2	11,000 hrs.

Example 2 (follow chain dotted line):

Side load (W)	(e) 11 kN
Load offset (A) from motor mounting face	(f) 50 mm
System pressure (P)	(g) 138 bar
Speed (N)	(h) 500 r/min.
Median bearing life	(i) 31,000 hrs.
L10 bearing rating = median x 0.2	6,200 hrs



Model Staffa

Page 13.70

Data Sheet M-1001/03.00



Bearing Life Graphs (continued)

HMB030 Shaft Types P, S, and Z

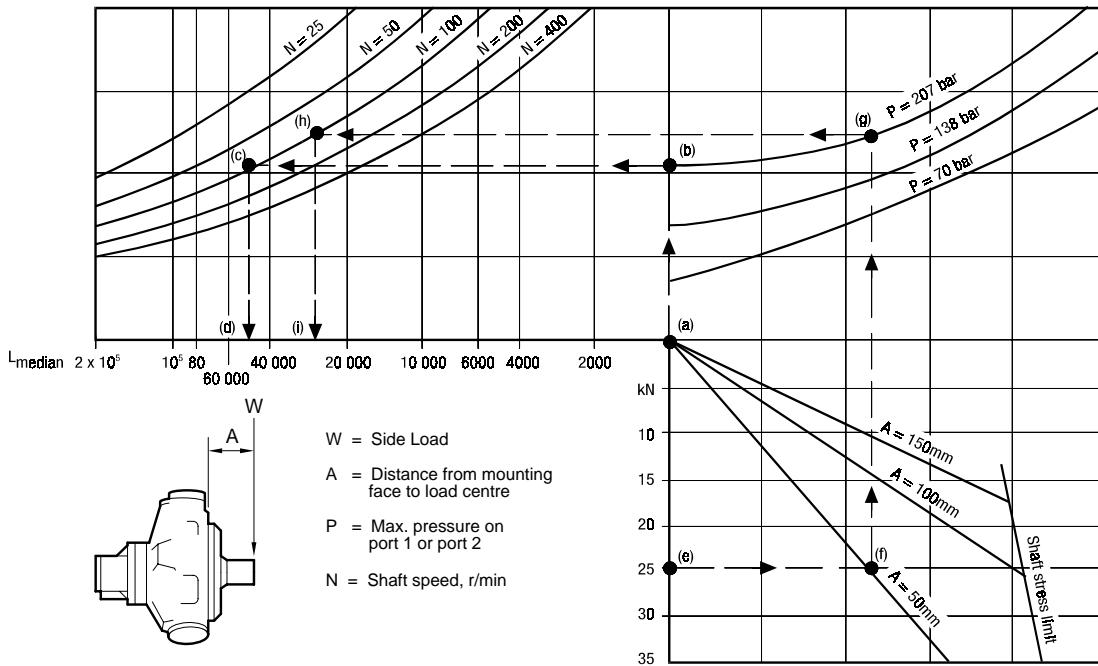

HMB045 Shaft Types P, S, and Z

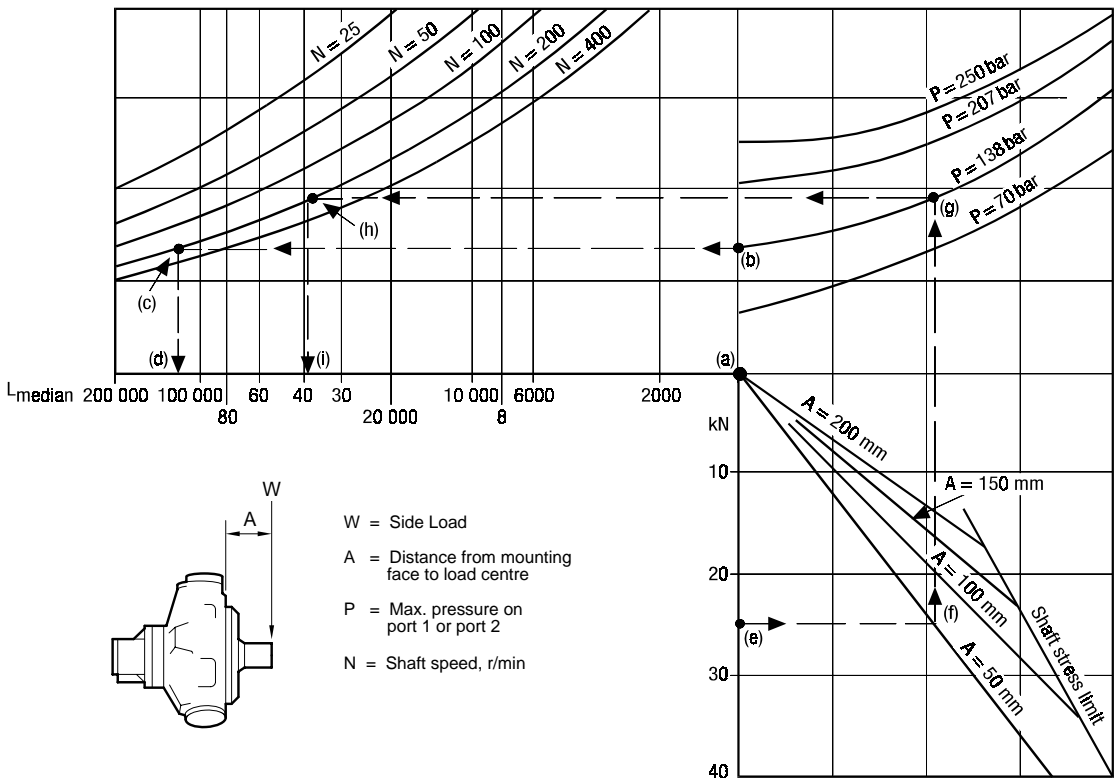

Bearing Life Graphs (continued)

HMB 060, HMB080, HMB100 Shaft Types P, S, Z, X

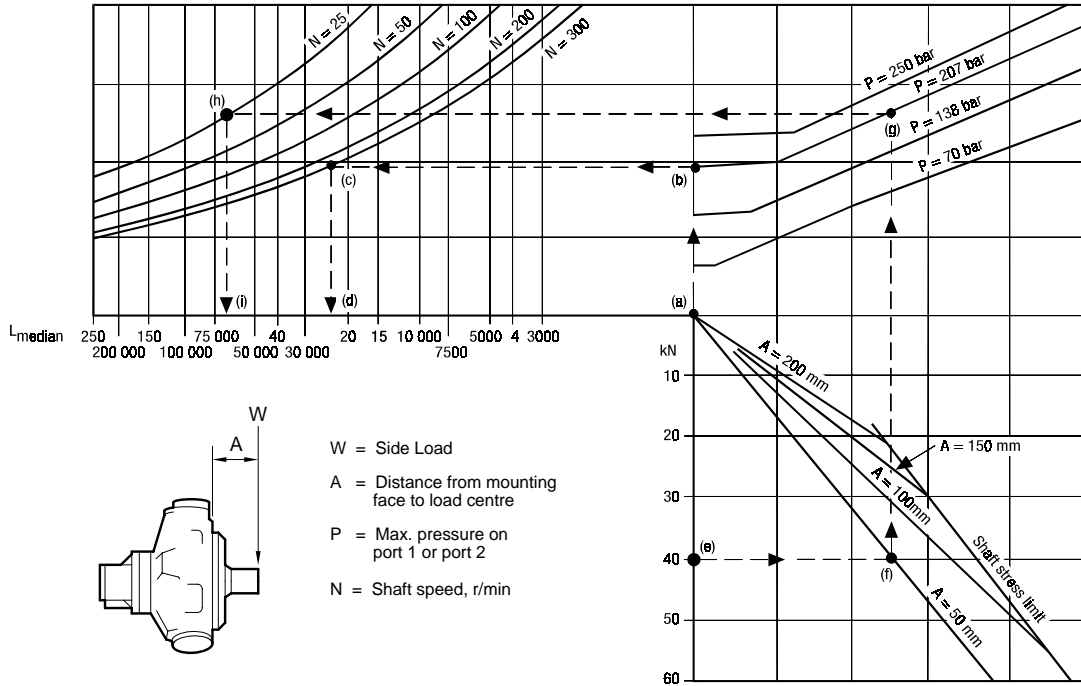

HMB125, HMB 150, HMB200 Shaft Types P1, S3, S4, Z3, T

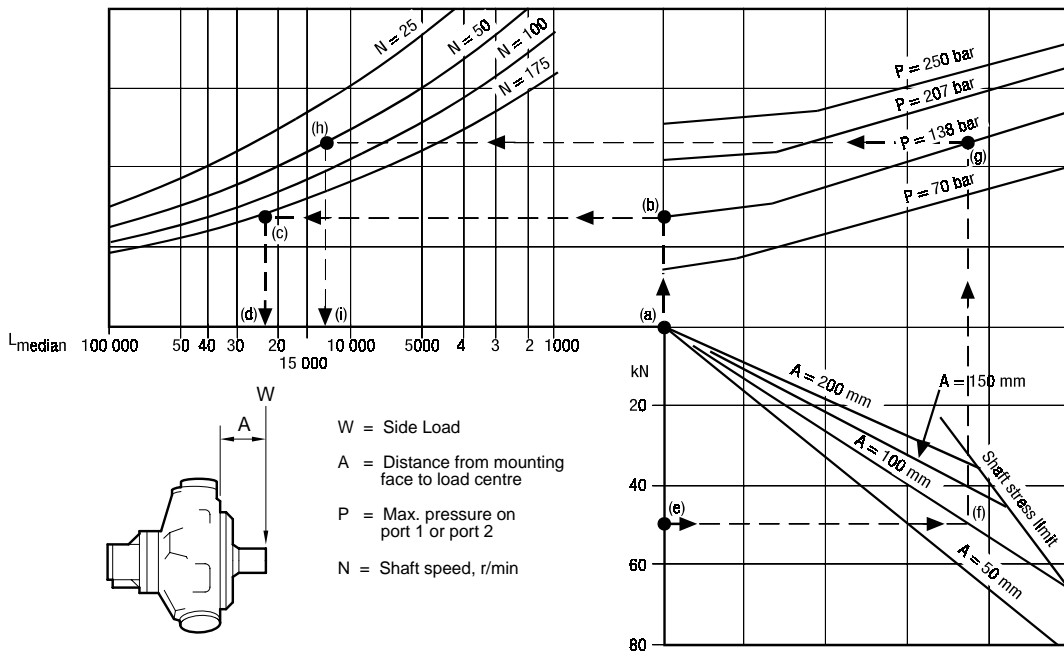

Model Staffa

Page 15.70

Data Sheet M-1001/03.00



Bearing Life Graphs (continued)

HMHDB125, 150, 200 Shaft Types S5, Z5 and P2

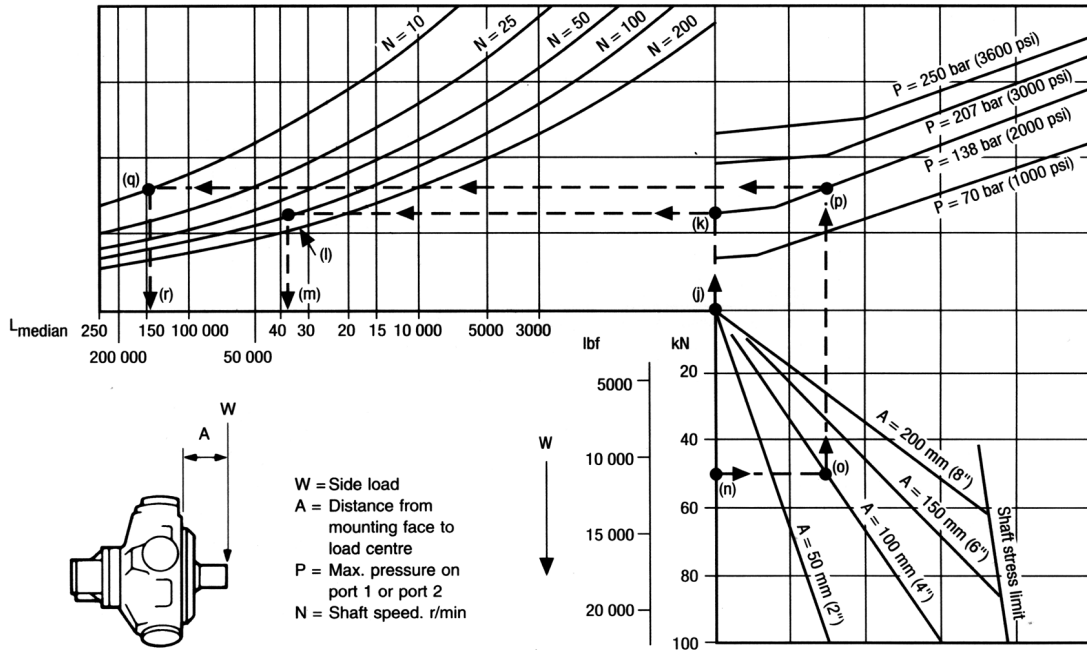

HMB270, HMB325 Shaft Types P1, S3, Z, T, X

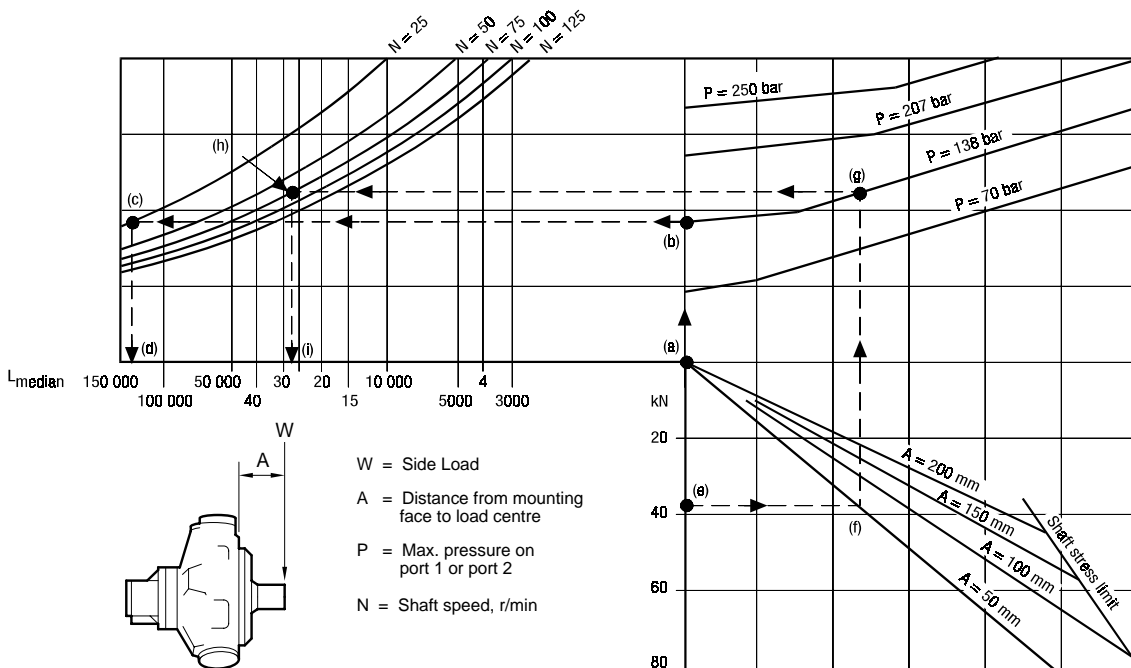

Bearing Life Graphs (continued)

HMHDB270, 325 Shaft Type P2, S5, Z and X

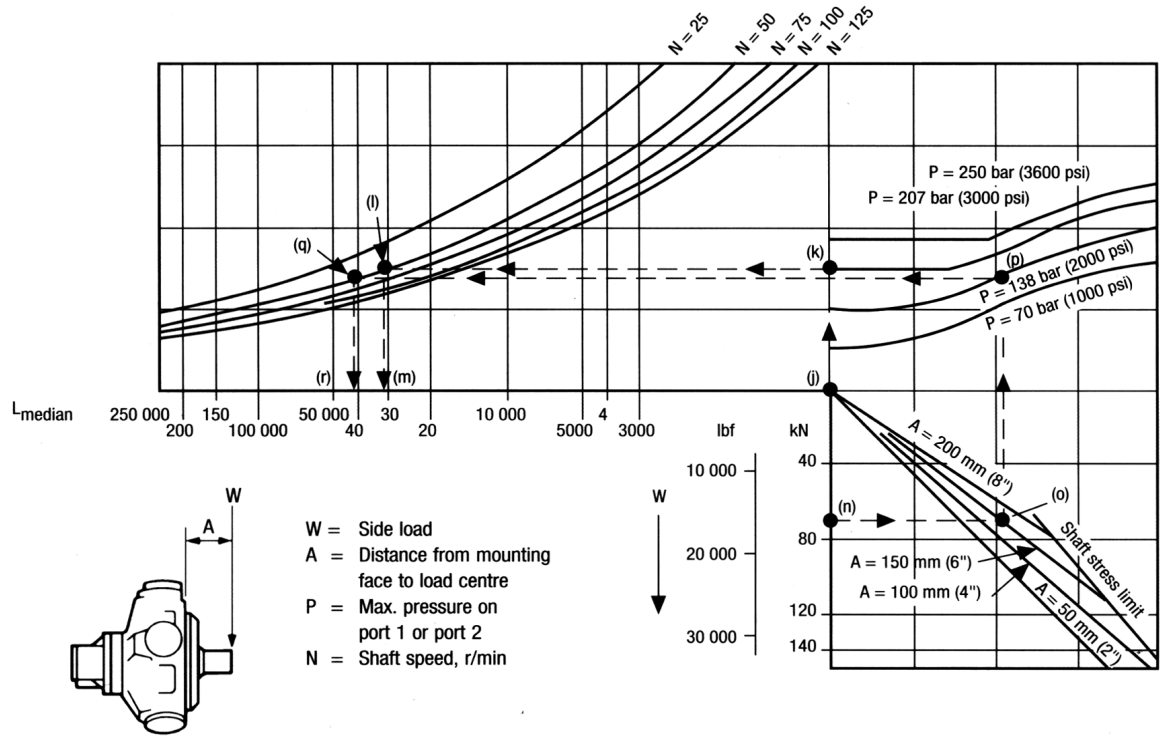

HMHDB400 Shaft Types P, S, Z, and X

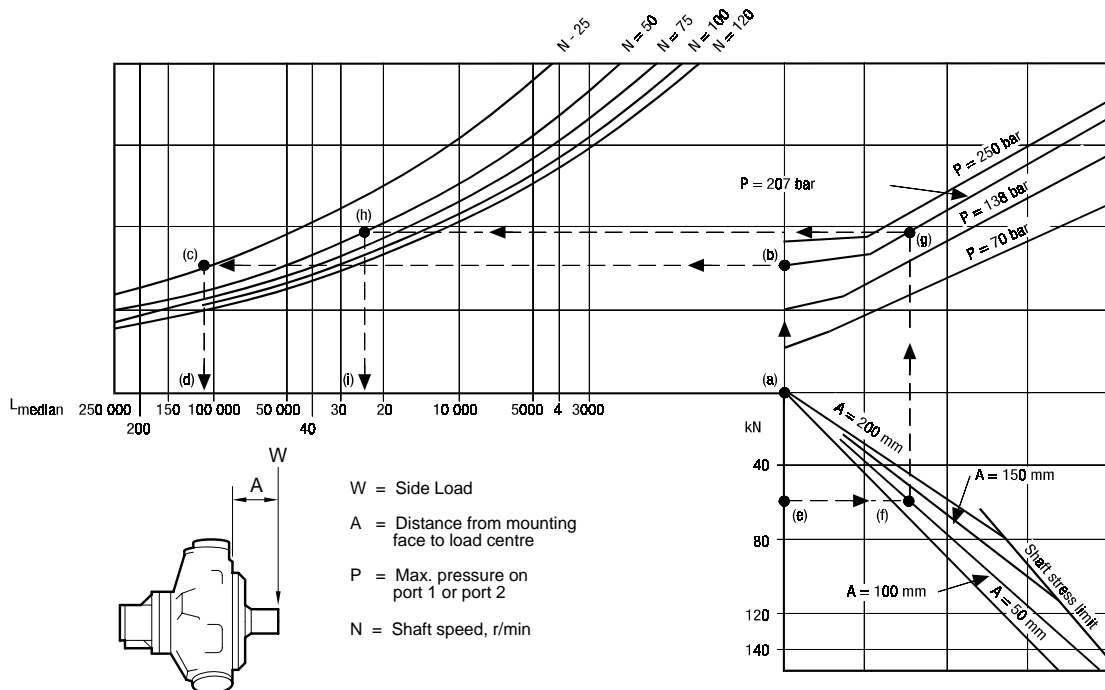

Model Staffa

Page 17.70

Data Sheet M-1001/03.00



Bearing Life Graphs (continued)

HMB700 Shaft Type P and Z

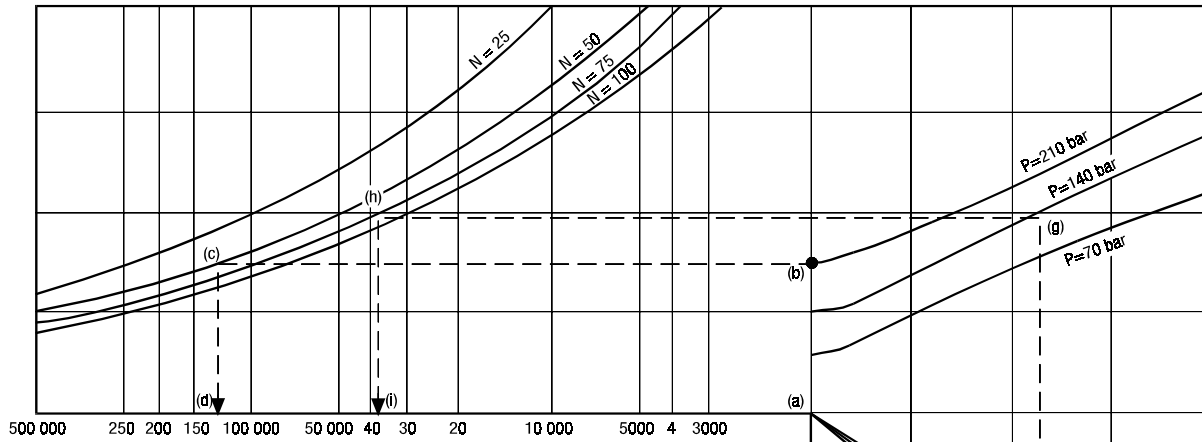

L_{median} hours life

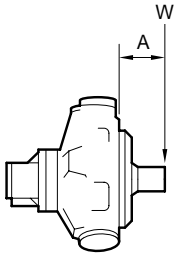

- W = Side Load
- A = Distance from mounting face to load centre
- P = Max. pressure on port 1 or port 2
- N = Shaft speed, r/min

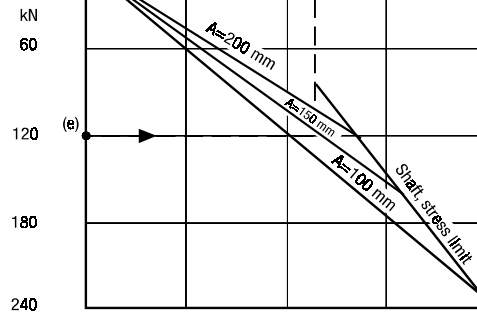

Volumetric Efficiency

These nomographs enable the average volumetric efficiency, crankcase (drain) leakage and “winch slip”/shaft creep speed to be estimated. The shaft creep occurs when the load attempts to rotate the motor against the closed ports as may occur, for example in winch applications.

B010

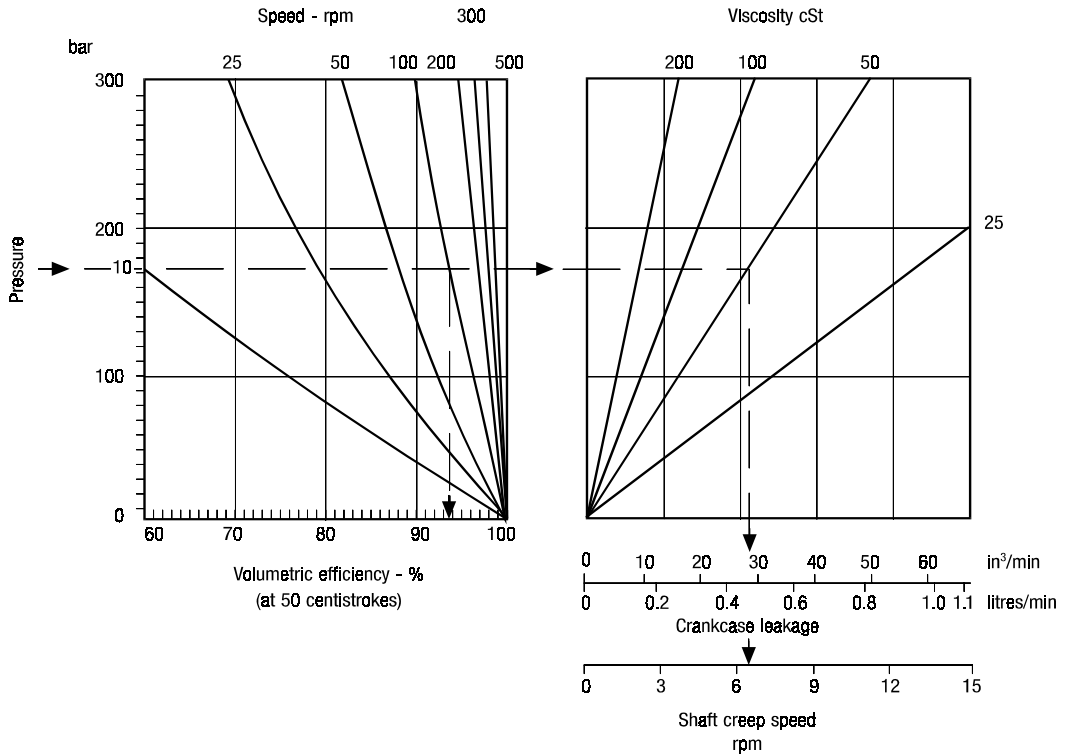

Example (follow chain dotted line):

Given:

- 1. Pressure..... 175 bar
- 2. Speed..... 100 r/min
- 3. Viscosity..... 50 cSt (232 SUS)

To obtain:

- 4. Volumetric efficiency94.2%
- 5. Crankcase leakage ...0.451 l/min (27.4 in³/min)
- 6. Shaft creep speed6.4 r/min

Model Staffa

Page 19.70

Data Sheet M-1001/03.00



Volumetric Efficiency (continued)

B030

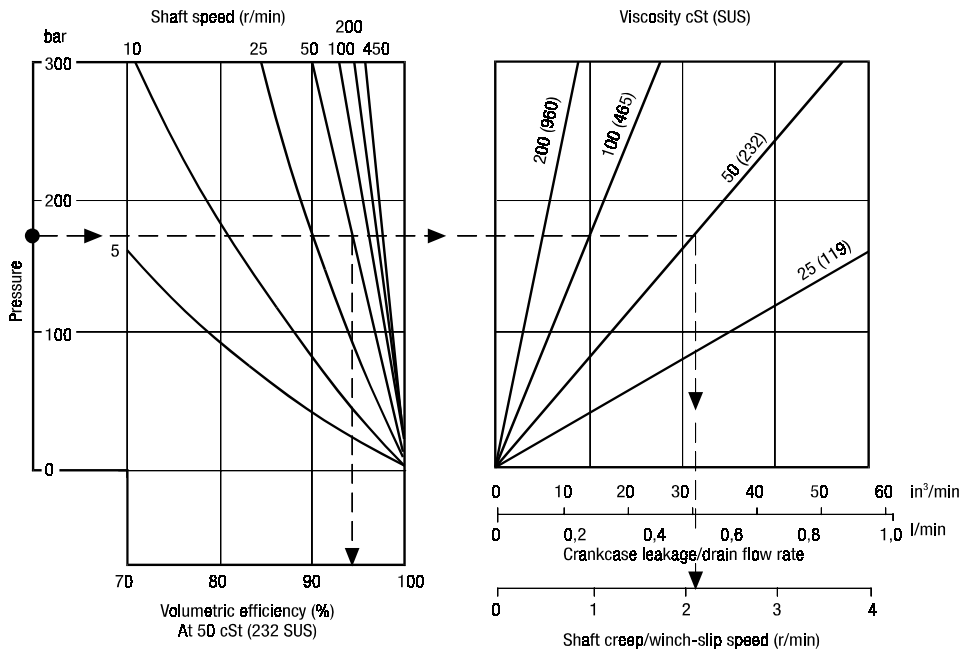

B045

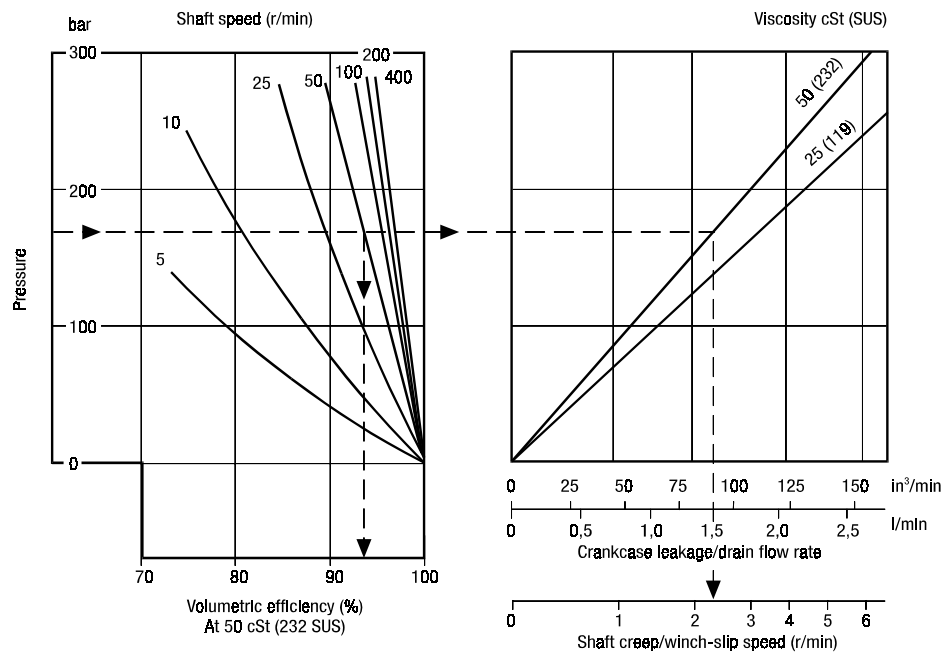

Volumetric Efficiency (continued)

B060

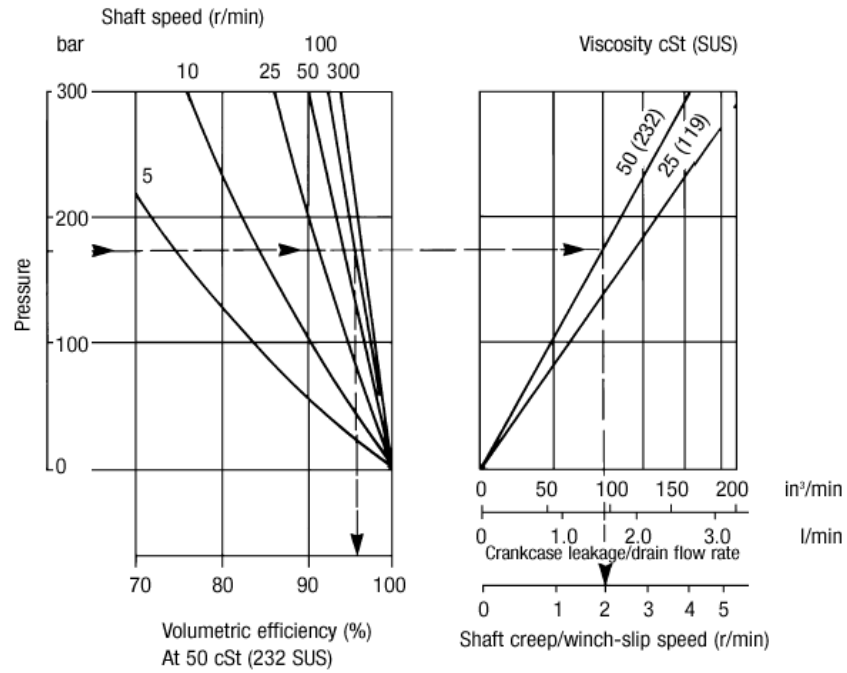

B080

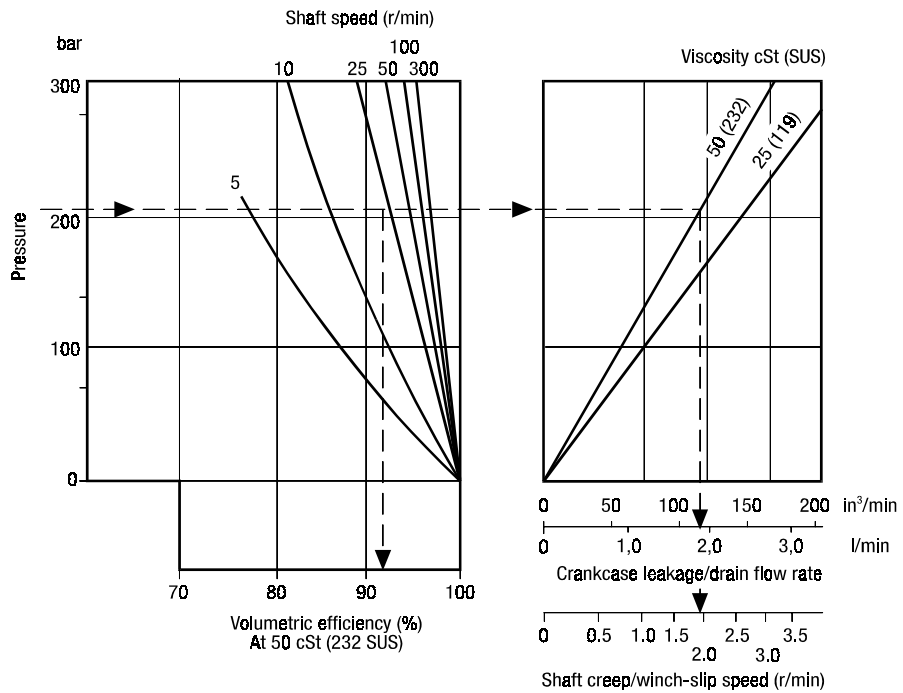

Model Staffa

Page 21.70

Data Sheet M-1001/03.00



Volumetric Efficiency (continued)

B100

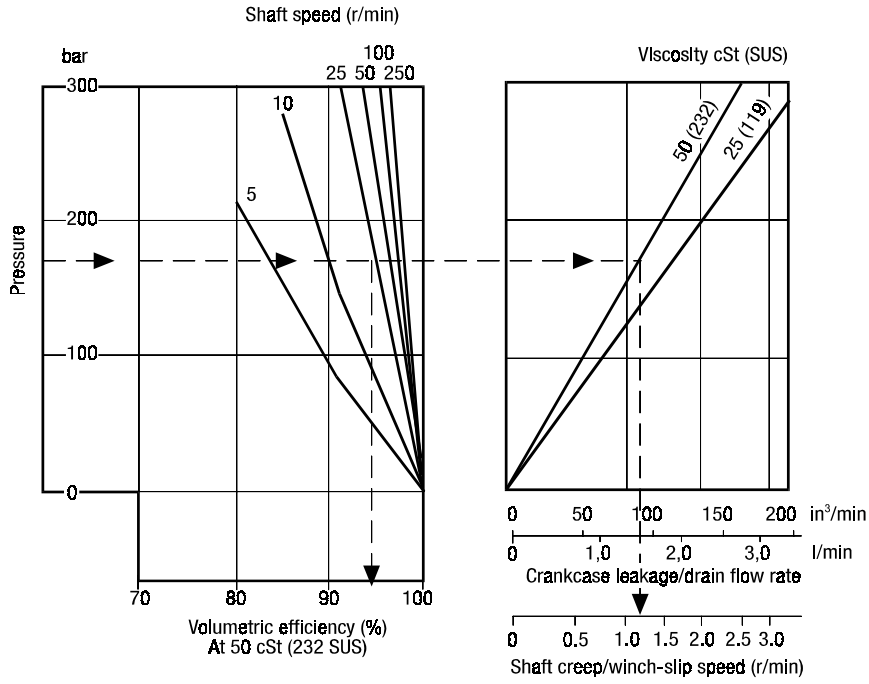

B125

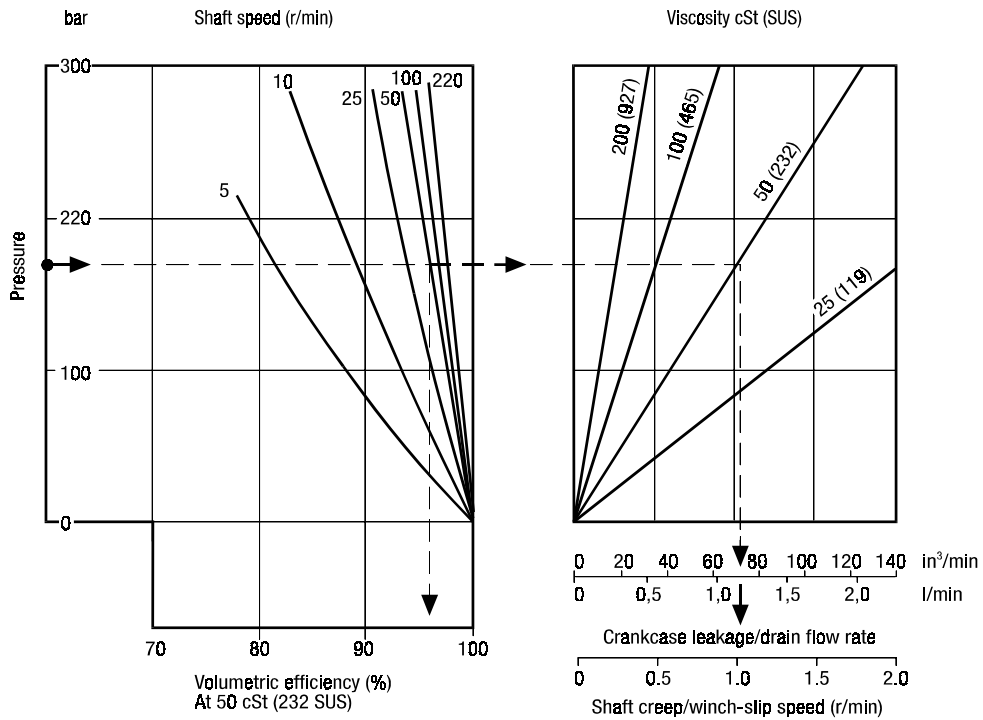

Volumetric Efficiency (continued)

B150

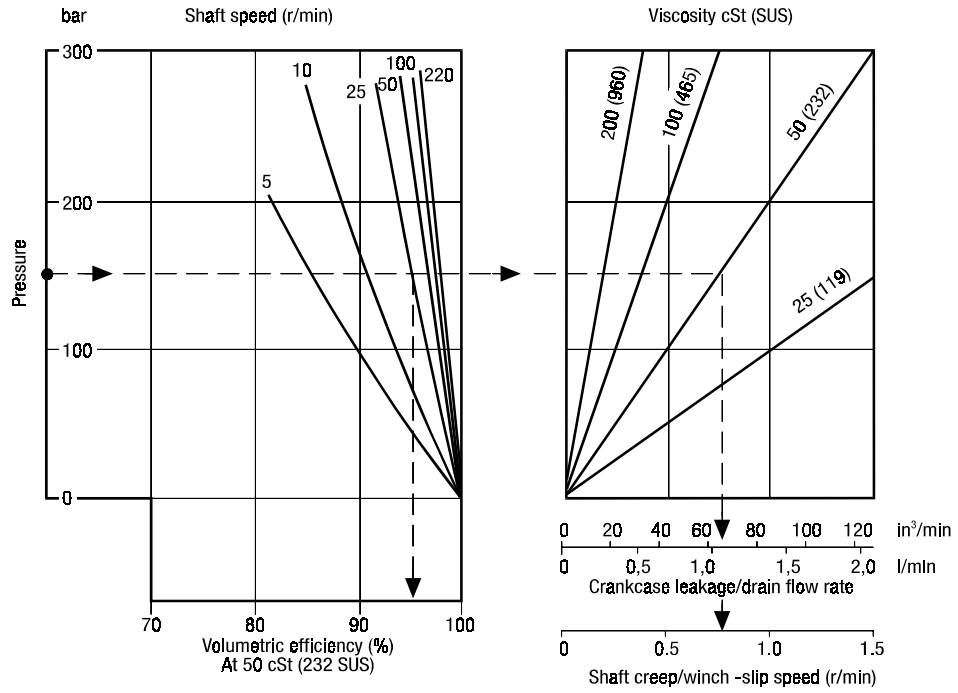

B200

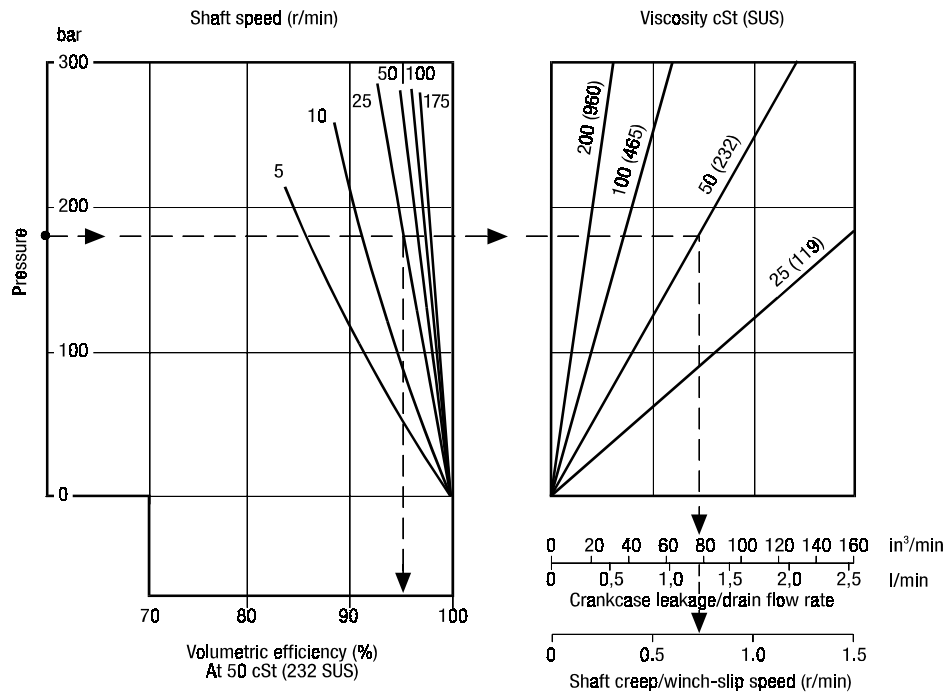

Model Staffa

Page 23/70

Data Sheet M-1001/03.00



Volumetric Efficiency (continued)

B270

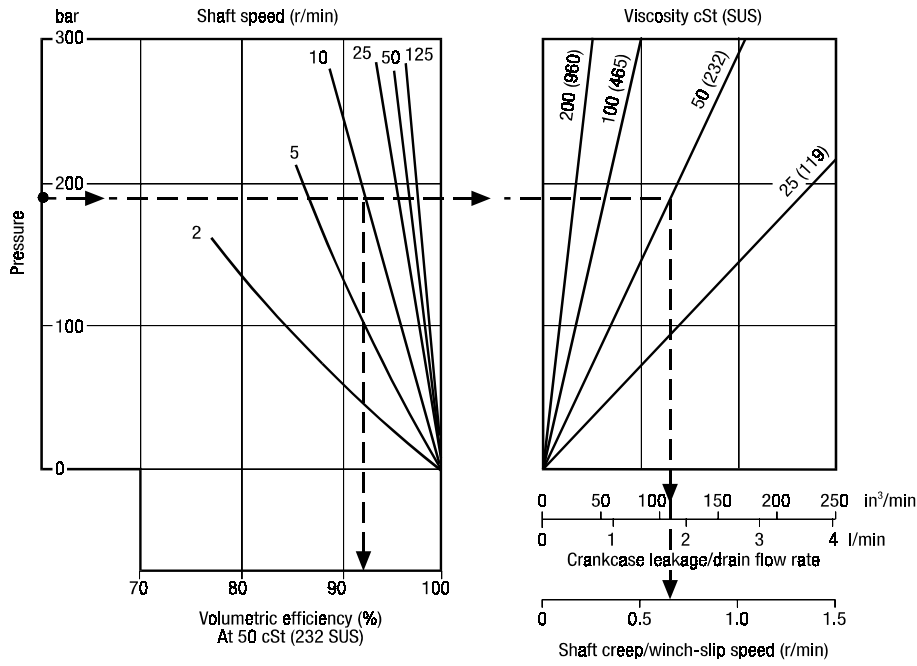

B325

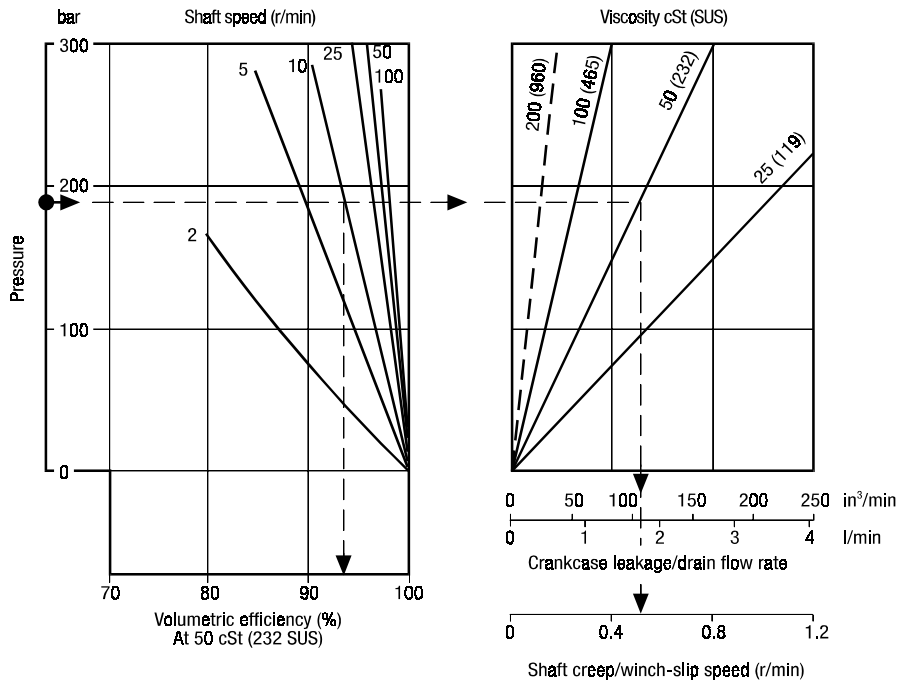

Volumetric Efficiency (continued)

B400

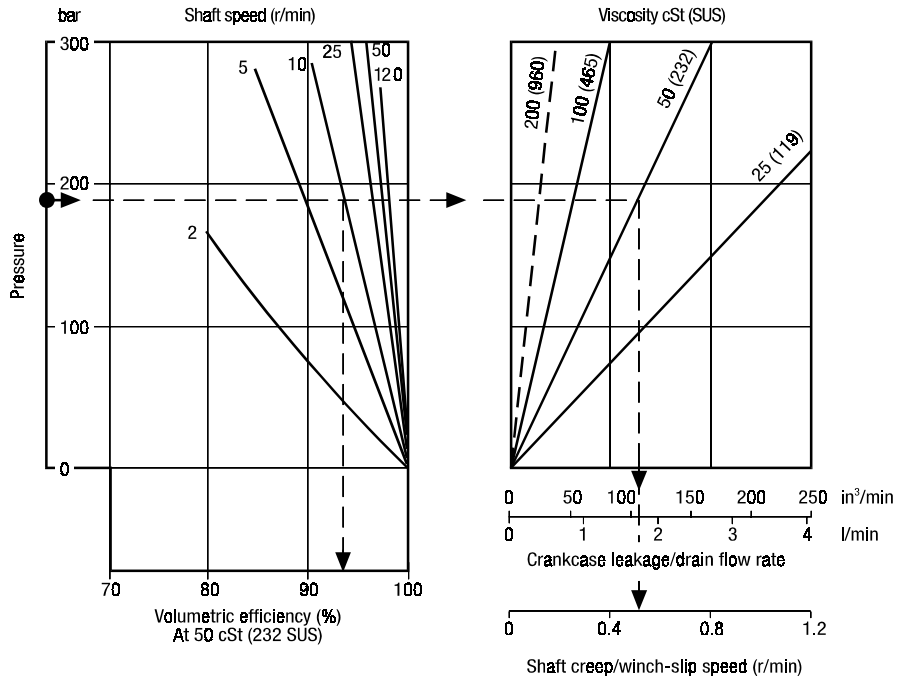

B700

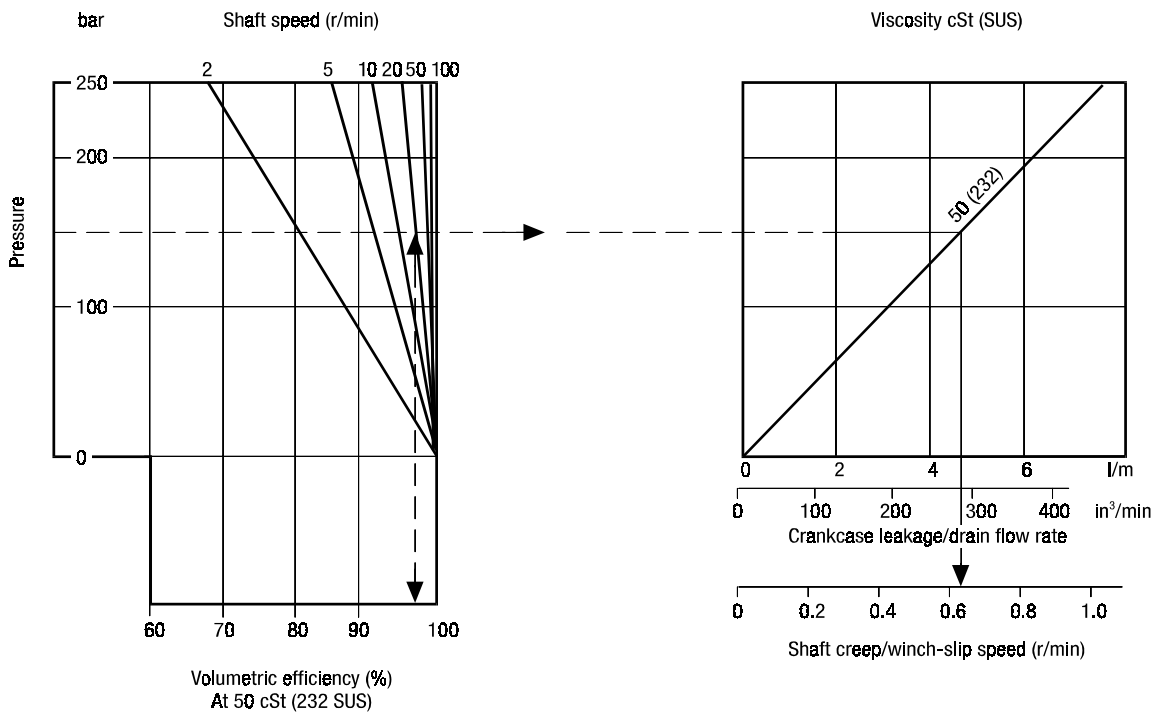

Model Staffa

Page 25.70

Data Sheet M-1001/03.00



Circuit and Application Notes**Starting Torque**

The starting torques shown on the graphs on pages 9 to 12 are average and will vary with system parameters.

Low Speed Operations

Minimum operating speeds are determined by the hydraulic system and load conditions (load inertia, drive elasticity, etc.) Recommended minimum speeds are shown below:

Model Type	r/min
B010	20
B030	5
B045	6
B06080/100/125/150/200	3
B270/B325/HMB400	2
B700	1

Note: Speed as low as 0.025 rpm can be accurately achieved using electronic control systems. For operation at speeds below these figures please contact Kawasaki Precision Machinery (UK) Ltd.

High Back Pressure

When both inlet and outlet ports are pressurised continuously, the lower port pressure must not exceed 70 bar at any time.

Note: High back pressure reduces the effective torque output of the motor.

Boost Pressure

When operating as a motor the outlet pressure should equal or exceed the crankcase pressure. If pumping occurs (i.e. overrunning loads) then a positive pressure, "P", is required at the motor ports. Calculate "P" (bar) from the operating formula

$$\text{Boost Formula } P = 1 + \frac{N^2 \times V^2}{K} + C$$

Where P is in Bar, N = motor speed (RPM), V = motor displacement (cc/rev.), C=Crankcase pressure (BAR) and K=a constant from the table below:

MOTOR	PORTING	CONSTANT
HMB010	Standard	8×10^8
HMB030	Standard	3.7×10^9
	SO3, F(M)3	7.5×10^9
HMB045	Standard	1.3×10^{10}
	SO3, F(M)3	1.6×10^{10}
HMB060/080/100	F(M)2	2.7×10^9
	F(M)3, S03	1.8×10^{10}
HM(HD)B125/150/200	F(M)2	4.2×10^9
	F(M)3, S03	4.0×10^{10}
	F(M)4, S04	8.0×10^{10}
HM(HD)B270/325	F(M)4, S04	7.2×10^{10}
HMHDB400	Standard	6.0×10^{10}
	S045	7.2×10^{10}
HMB700	Standard	1.3×10^{11}



Circuit and Application Notes (continued)

The flow rate of oil needed for the make-up system can be estimated from the crankcase leakage figure (see Volumetric Efficiency graphs pages 19 to 29) Allowances should be made for other system losses and also for “fair wear and tear” during the life of the motor, pump and system components.

Cooling Flow

Operating within the continuous rating does not require any additional cooling.
 For operating conditions above “continuous”, up to the “intermittent” rating, additional cooling oil may be required.
 This can be introduced through the spare crankcase drain holes, or in special cases through the valve spool end cap. Consult Kawasaki about such applications.

Motor Casing Pressure

With the standard shaft seal fitted, the motor casing pressure should not exceed 3.5 bar.

Notes:

1. The casing pressure at all times must not exceed either the motor inlet or outlet pressure.
2. High pressure shaft seals are available for casing pressures of:
 - 6 Bar for HMB700
 - 9 Bar for HMB 010
 - 10 Bar for all remaining frame sizes.
3. Check installation dimensions for maximum crankcase drain fitting depth.

Hydraulic Fluids

Dependent on motor (see Ordering Code.) suitable fluids include:

- (a) Antiwear hydraulic oils.
- (b) Phosphate ester (HFD fluids)
- (c) Water glycols (HFC fluids)
- (d) 60/40% water-in-oil emulsions (HFB fluids).
- (e) 5/95% oil-in-water emulsions (HFA fluids)

Reduce pressure and speed limits, see page 6.

Viscosity limits when using any fluid except oil-in-water (5/95) emulsions are;

Max. off load	2000cSt (9270 SUS)
Max. on load	150 cSt (695 SUS)
Optimum	50 cSt (232 SUS)
Minimum	25cSt (119 SUS)



Model Staffa	Page 27.70	Data Sheet M-1001/03.00
--------------	------------	-------------------------



Circuit and Application Notes (continued)**Mineral Oil recommendations**

The fluid should be a good hydraulic grade, non-detergent Mineral Oil. It should contain anti-oxidant, anti-foam and demulsifying additives. It should contain antiwear or EP additives. Automatic transmission fluids and motor oils are not recommended.

Temperature limits

Ambient min.	-30°C (-22°F)
Ambient max.	+ 70°C (158°F)
Max. operating temperature range.	
Mineral Oil	Water- containing
Min -20°C (-4°F)	+10°C (50°F)
Max. + 80°C (175°F)	+54°C (130°F)

Note: To obtain optimum services life from both fluid and hydraulic systems components, a fluid operating temperature of 40°C is recommended.

Filtration

Full flow filtration (open circuit), or full boost flow filtration (close circuit) to ensure system cleanliness to ISO4406/1986 code 18/14 or cleaner.

Noise levels

The airborne noise level is less than 66.7 dB(A) DIN (&) dB (A) NFPA) through the “continuous” operating envelope. Where noise is a critical factor, installation resonances can be reduced by isolating the motor by elastomeric means from the structure and the return line installation. Potential return line resonances originating from liquid borne noise can be further attenuated by providing a return line back pressure of 2 to 5 bar.

Polar Moment of Inertia & Mass:

Model Type	Polar moment of Inertia (kg.m ²) (Typical data)	Mass (kg) (Approx. all models)
HMB010	0.0076	40
HMB030	0.015	73
HMB045	0.047	120
HMB060	0.055	144
HMB080	0.060	144
HMB100	0.076	144
HMB125	0.22	217
HMB150	0.25	265
HMB200	0.27	265
HMB270	0.91	420
HMB325	0.95	429
HMHDB400 (With 4" valve)	0.54	481
HMHDB400 (With 4.5" valve)	0.54	510
HMB700	2.38	1050



Crankcase Drain

Motor axis horizontal.

The crankcase drain must be taken from a position above the horizontal centre line of the motor to ensure lubrication of the shaft bearing

Axis vertical, shaft down.

Use either drain position. The drain line should be run above the level of the uppermost bearing. If there is a risk of syphoning then a syphon breaker should be fitted.

Axis vertical, shaft up.

An additional G 1/4" (BSPF) drain port is provided when "V" (shaft vertically upwards) designator is given after the shaft type (see Ordering Code). This additional drain should be connected into the main motor casing drain line downstream of a 0.35 bar check valve to ensure lubrication of the upper bearing, see diagram.

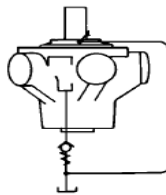

Installation Data

GENERAL

Spigot:

The motor should be located by the mounting spigot on a flat, robust surface using correctly sized bolts. The diametrical clearance between the motor spigot and the mounting must not exceed 0.15mm. If the application incurs shock loading, frequent reversing or high speed running , then high tensile bolts should be used , including one fitted bolt.

Bolt Torque:

The recommended torque wrench setting for bolts are as follows:

M12	97 +/- 7Nm
M14	160 +/- 21Nm
M18	312 +/- 14Nm
M20	407 +/- 14Nm
M24	690 +/- 27Nm
1/2" UNF	97 +/- 7Nm
5/8"	265 +/- 14 Nm
3/4" bolts	393 +/- 14 Nm
1"	810 +/- 27Nm

Shaft Coupling:

Where the motor is solidly coupled to a shaft having independent bearings the shaft must be aligned to within 0.13mm TIR



Model Staffa

Page 29.70

Data Sheet M-1001/03.00

Installation Drawings HMB010 Motor

(See additional views for shaft types)

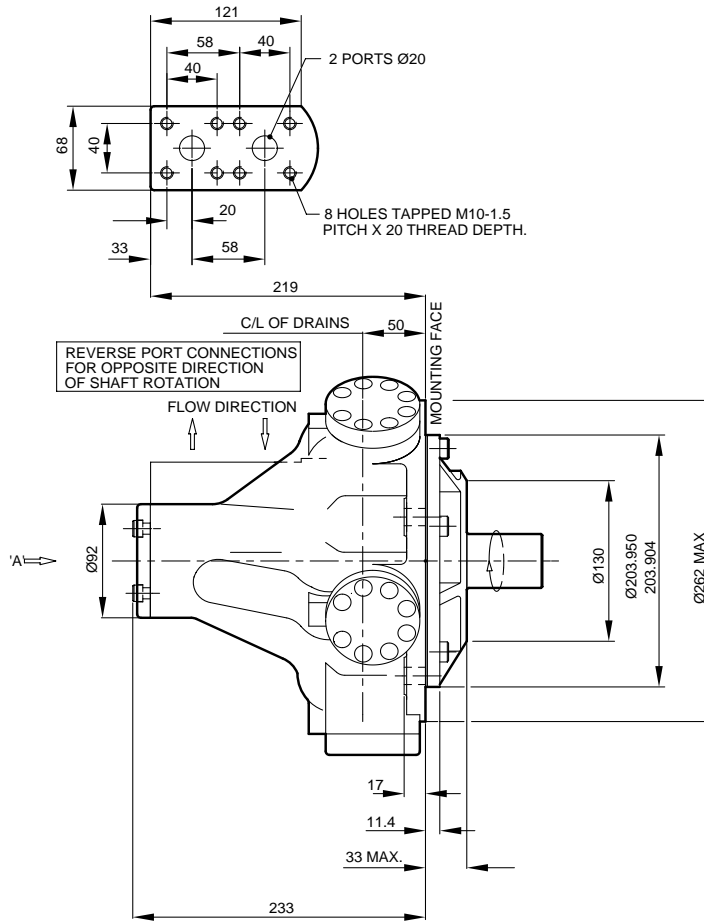

3/8-BSP DRAIN (CHOICE OF 3 POSITIONS)
(2 NORMALLY PLUGGED)

NOTE:
ENSURE ON INSTALLATION DRAIN IS
TAKEN FROM ABOVE MOTOR C
DO NOT EXCEED 12 DEPTH OF
COUPLING INTO DRAIN PORT

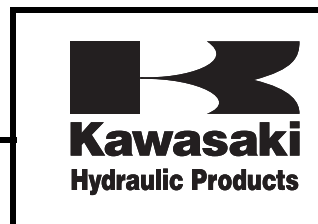
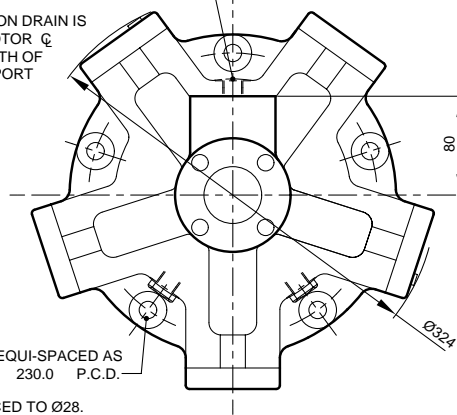

Shaft Specification HMB010

SHAFT TYPE 'S'
13 SPLINES TO BS 3550-

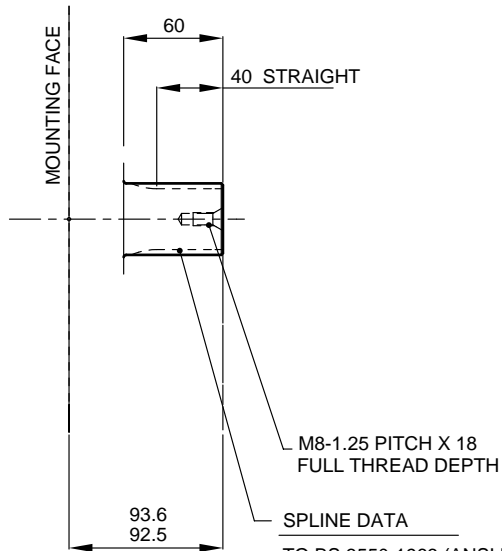

SPLINE DATA	
TO BS 3550-1963 (ANSI B92.1, 1970 CLASS 5)	
FLAT ROOT SIDE FIT, CLASS 1	
PRESSURE ANGLE	30°
NUMBER OF TEETH	13
PITCH	8/16
MAJOR DIAMETER	43.71/43.59
FORM DIAMETER	38.136
MINOR DIAMETER	37.36/36.91
PIN DIAMETER	6.096
DIAMETER OVER PINS	50.104/50.152

**SHAFT TYPE 'P'
CYLINDRICAL SHAFT WITH KEY**

KEY (SUPPLIED):
10.030/10.015 WIDE
8.000/7.964 THICK

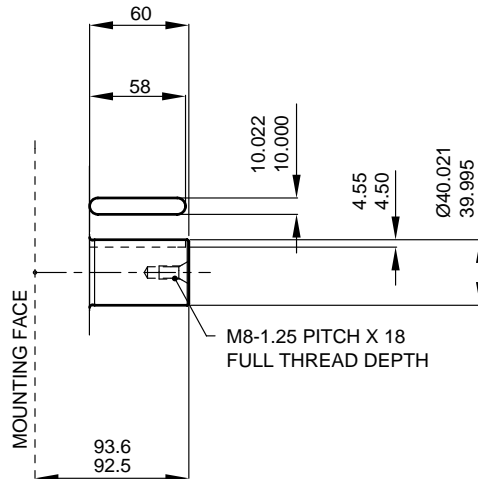

Model
Staffa

Page
31.70

Data Sheet
M-1001/03.00



Installation Drawings

HMB030 motor with rear entry ports (Mono block)

See additional views for side entry model and for shaft types

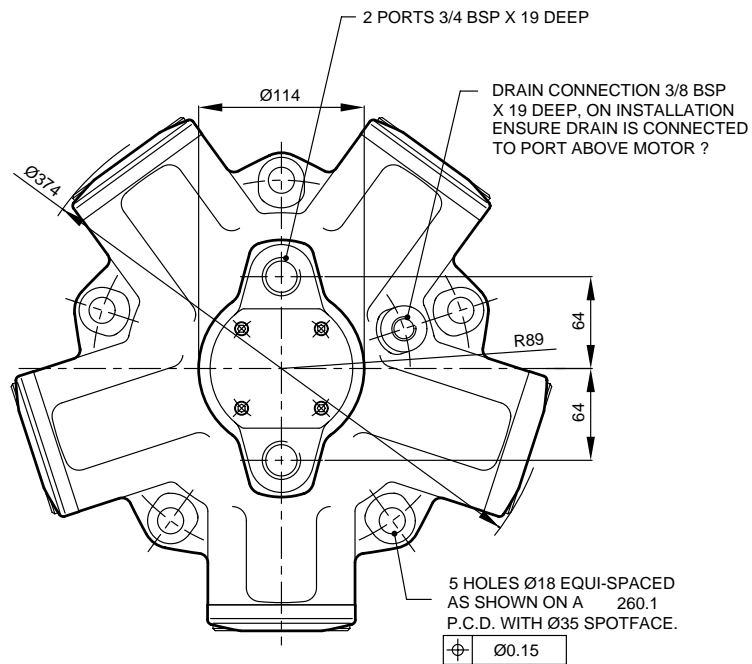
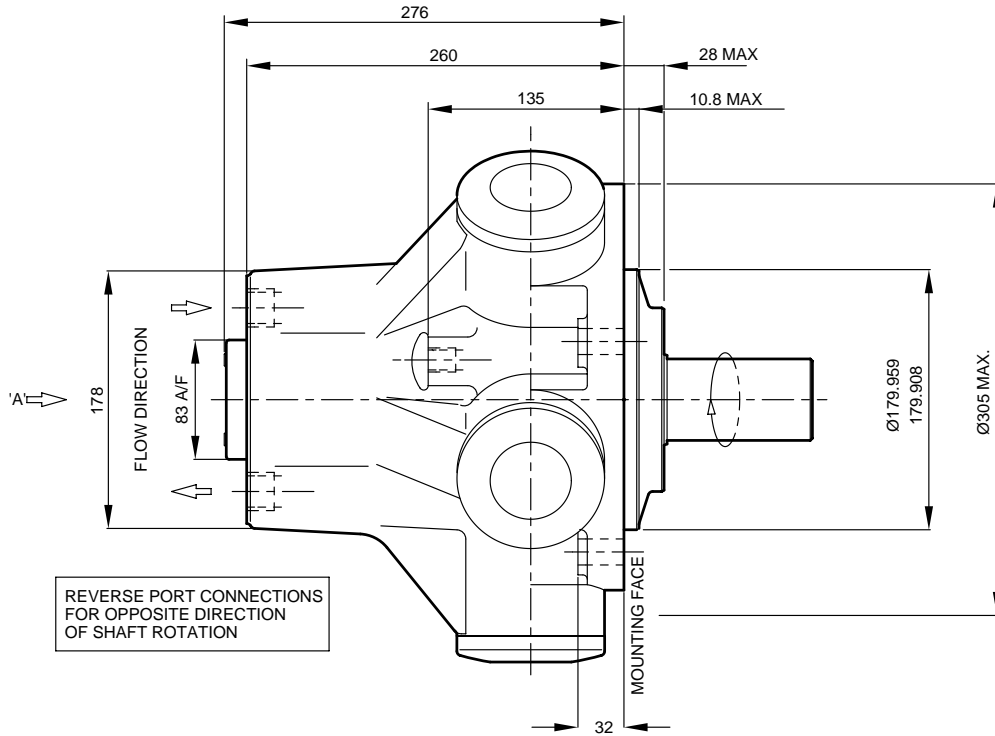

VIEW ON ARROW 'A'



HMB030 Motor

HMB030 motor with side entry ports (Mono block)

See view of rear entry motor for additional shaft types.

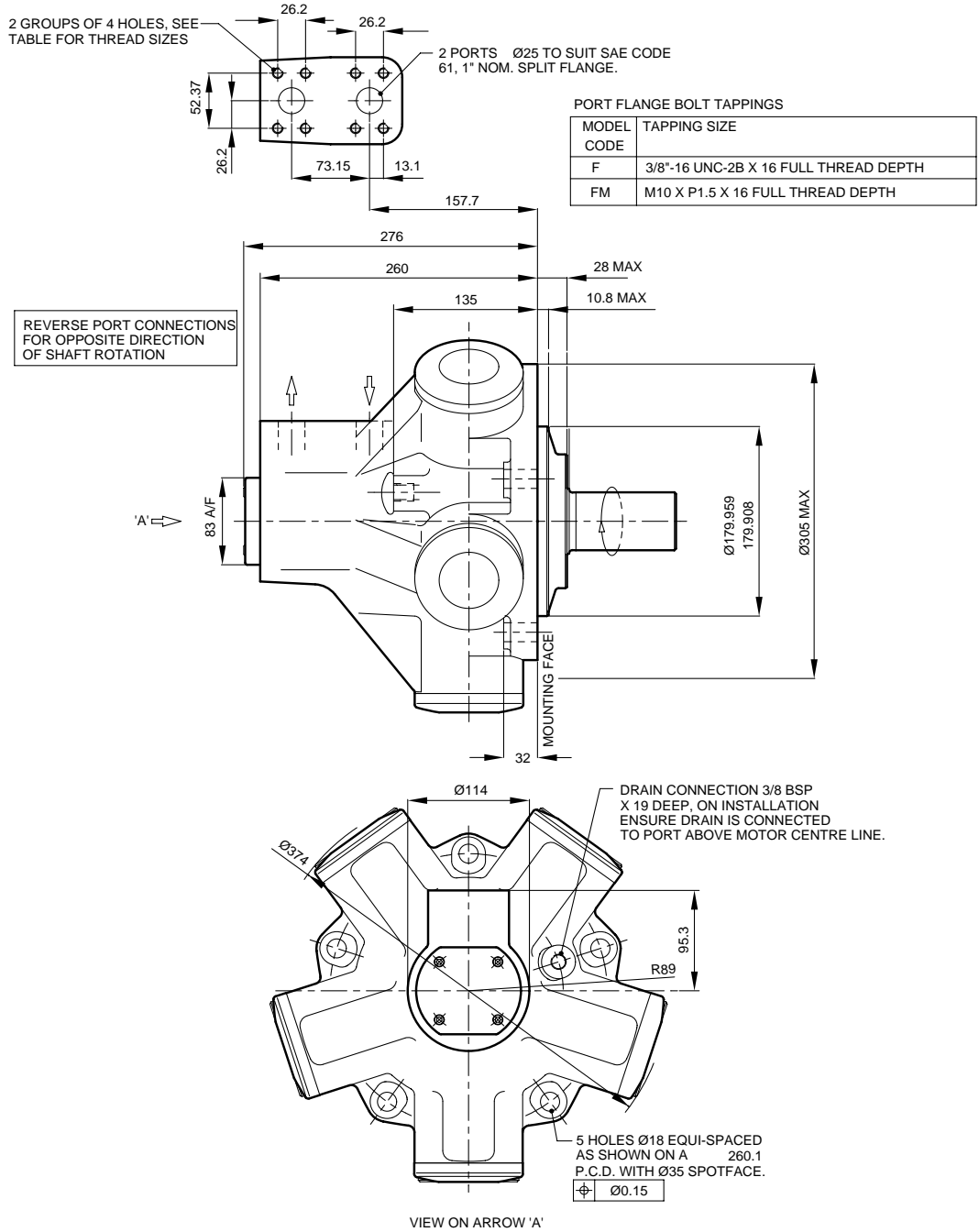

Model Staffa

Page 33.70

Data Sheet M-1001/03.00



Installation Drawing

HMB030 with F3/FM3 Main Port Connections

PORT FLANGE BOLT TAPPINGS

MODEL CODE	TAPPING SIZE	GAUGE CONNECTIONS
F3	7/16"-14 UNC-2B X 27 FULL THREAD DEPTH	19/16"-18 UNF-2B, SAE J475
FM3	M12 X P1.75 X 27 FULL THREAD DEPTH	G1/4" (BSPF)

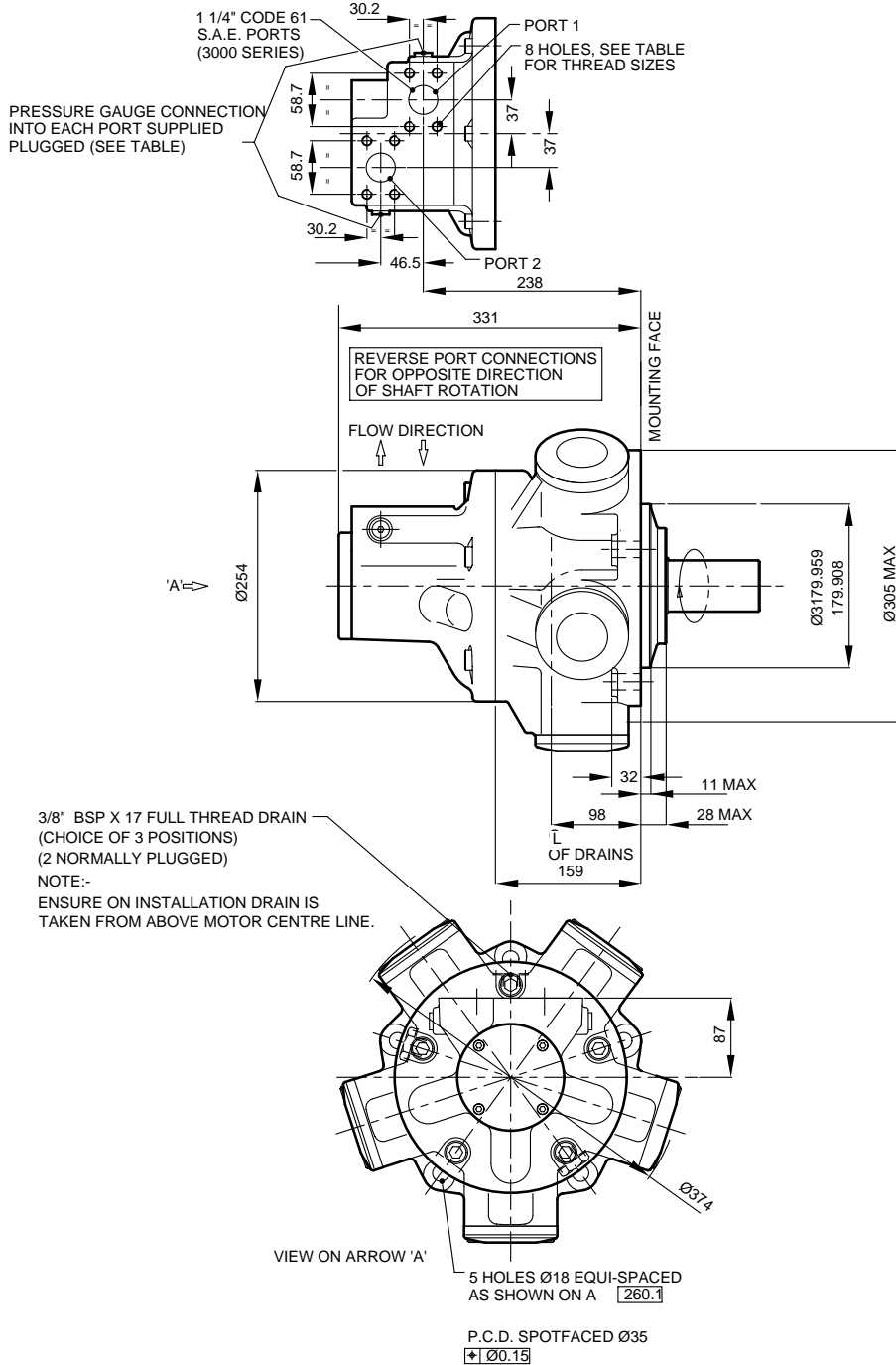

HMB30 Shaft Specification

Shaft Type "P" Parallel keyed shaft

Shaft Type "S" Involute spline, 17 teeth to BS3550

Shaft Type "Z" Involute spline, 17 teeth to DIN 5480

SHAFT TYPE 'S'
17 SPLINES TO BS 3550-1963

SHAFT TYPE 'Z'
17 SPLINES TO DIN 5480

FOR SHAFT TYPE 'Z'
DIN 5480, W55 X 3 X 17 X 7h

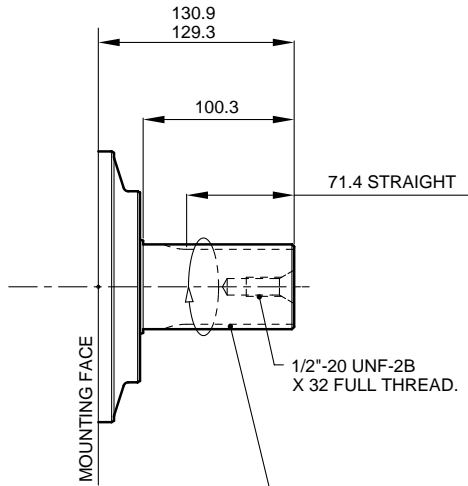

SPLINE DATA

FOR SHAFT TYPE 'S'
TO BS 3550-1963 (ANSI B92.1, 1970 CLASS 5)
FLAT ROOT SIDE FIT, CLASS 1

PRESSURE ANGLE	30°
NUMBER OF TEETH	17
PITCH	8/16
MAJOR DIAMETER	56.41/56.28
FORM DIAMETER	50.703
MINOR DIAMETER	50.07/49.60
PIN DIAMETER	6.096
DIAMETER OVER PINS	62.985/62.931

SHAFT TYPE 'P'
CYLINDRICAL SHAFT WITH KEY

KEY (SUPPLIED):
14.046/14.028 WIDE
9.037/8.961 THICK

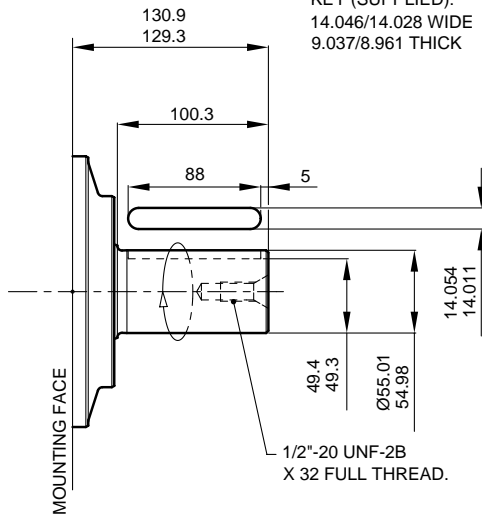

Model
Staffa

Page
35.70

Data Sheet
M-1001/03.00



Installation Drawings

HMB045--3* Motor with rear entry ports**
HMB045--D-3* Motor with dual entry ports**

SEE VIEWS FOR ADDITIONAL SHAFT TYPES

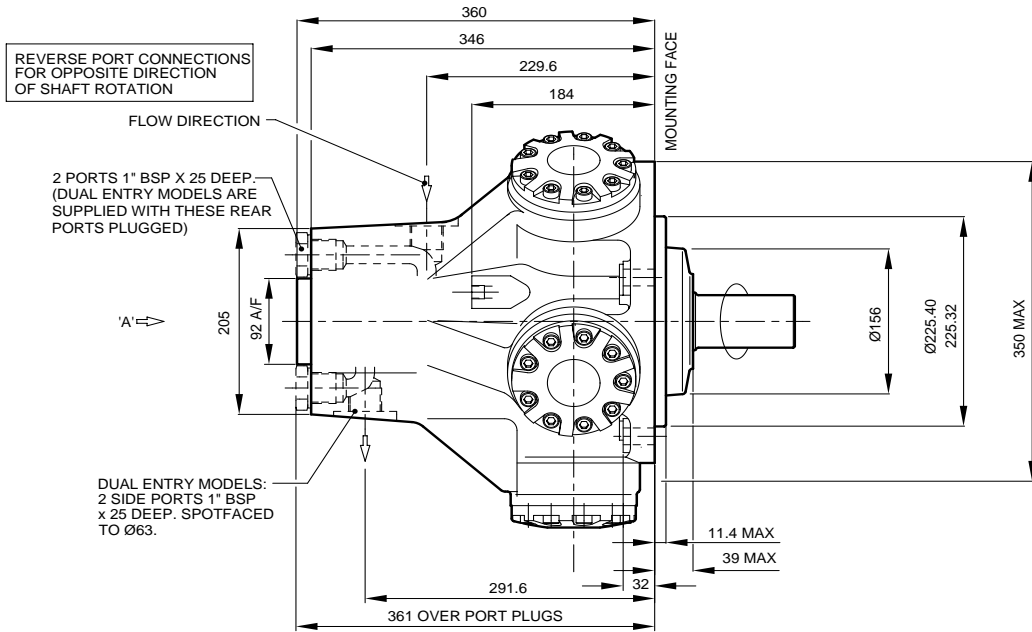

DRAIN CONNECTION 3/8 BSP x 19 DEEP SPOTFACED TO Ø28. CHOICE OF TWO POSITIONS ONE NORMALLY PLUGGED. ON INSTALLATION ENSURE DRAIN IS CONNECTED TO PORT ABOVE MOTOR C/L

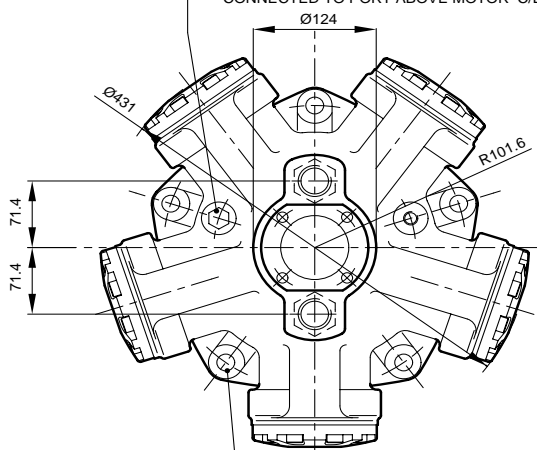

5 HOLES Ø18 EQUI-SPACED AS SHOWN ON A [305] P.C.D. SPOTFACED TO Ø38.

⊕ Ø0.15

VIEW ON ARROW 'A'

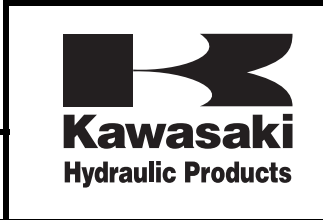

Installation Drawing

HMB045-FM3 Motor

PORT FLANGE BOLT TAPPINGS

MODEL CODE	TAPPING SIZE	GAUGE CONNECTIONS
F3	7/16"-14 UNC-2B X 27 FULL THREAD DEPTH	9/16"-18 UNF-2B, SAE J475
FM3	M12 X P1.75 X 27 FULL THREAD DEPTH	G1/4 (BSPF)

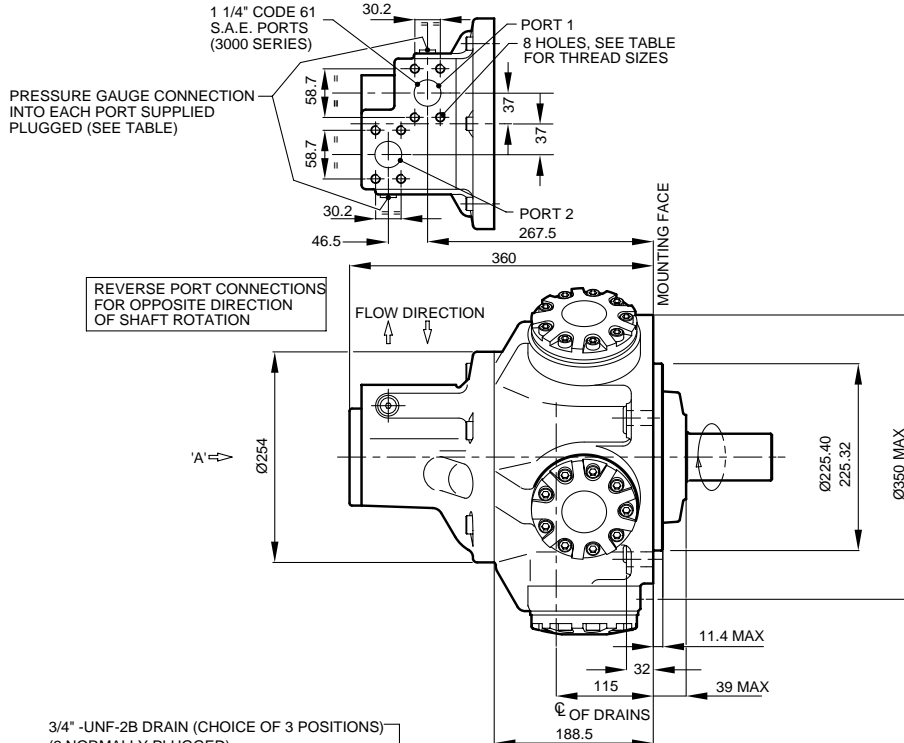

3/4" -UNF-2B DRAIN (CHOICE OF 3 POSITIONS)
(2 NORMALLY PLUGGED)

NOTE:-
ENSURE ON INSTALLATION DRAIN IS
TAKEN FROM ABOVE MOTOR C/L
DO NOT EXCEED 12 DEPTH OF
COUPLING INTO DRAIN PORT

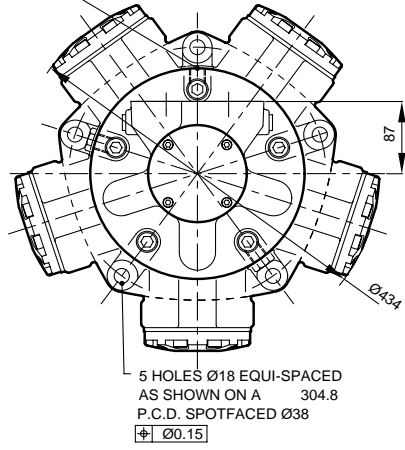

VIEW ON ARROW 'A'



Model
Staffa

Page
37.70

Data Sheet
M-1001/03.00



B045 Shaft Specification

Shaft type "P", Parallel keyed shaft

Shaft type "S", Involute spline, 17 teeth to BS3550

Shaft type "Z", Involute spline to DIN 5480

Shaft type "Q", Internal Involute spline, 21 teeth to BS 3550

B045 SHAFT VARIATIONS

SHAFT TYPE 'P'
CYLINDRICAL SHAFT WITH KEY

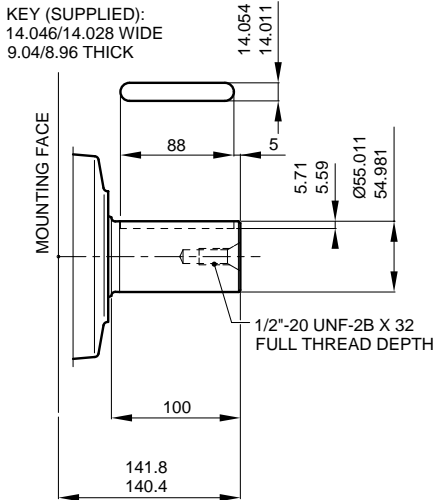

SHAFT TYPES 'S'
17 SPLINES TO BS 3550-1963

SHAFT TYPES 'Z'
17 SPLINES TO DIN 5480

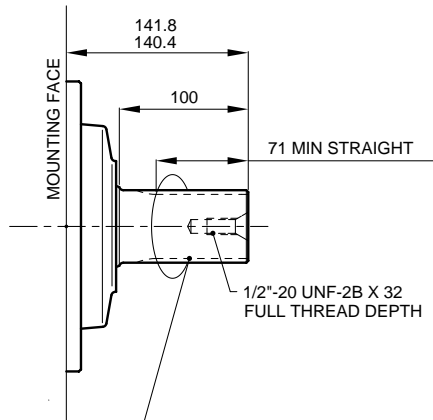

SPLINE DATA

FOR SHAFT TYPE 'S'
TO BS 3550-1963 & ANSI B92.1,1970
FLAT ROOT SIDE FIT, CLASS 1
PRESSURE ANGLE 30°
NUMBER OF TEETH 17
PITCH 8/16
MAJOR DIAMETER 56.41/56.28
FORM DIAMETER 50.703
MINOR DIAMETER 50.07/49.60
PIN DIAMETER 6.096
DIAMETER OVER PINS 62.985/62.931

SHAFT TYPE 'Q'
FEMALE SHAFT WITH 21 SPLINES TO BS 3550

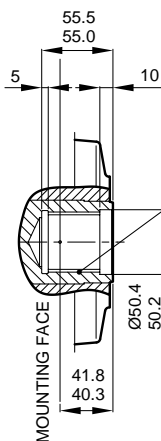

SPLINE DATA

INTERNAL SPLINE TO BS 3550-1963
FLAT ROOT SIDE FIT
PRESSURE ANGLE 30°
NUMBER OF TEETH 21
PITCH 12/24
MAJOR DIAMETER 46.566/46.896
FORM DIAMETER 46.144
MINOR DIAMETER 42.334/42.461
PIN DIAMETER 3.658
PIN FLATTED TO 3.556
DIMENSION BETWEEN PINS 39.169/39.103

FOR SHAFT TYPE 'Z'
DIN 5480, W55 X 3 X 17 X 7h



HMB030/HMB045 Valve Housings

**3" VALVE HOUSING WITH 6-BOLT FLANGE, 'S03'
SUPPLIED WITH 2 'O' RING SEALS**

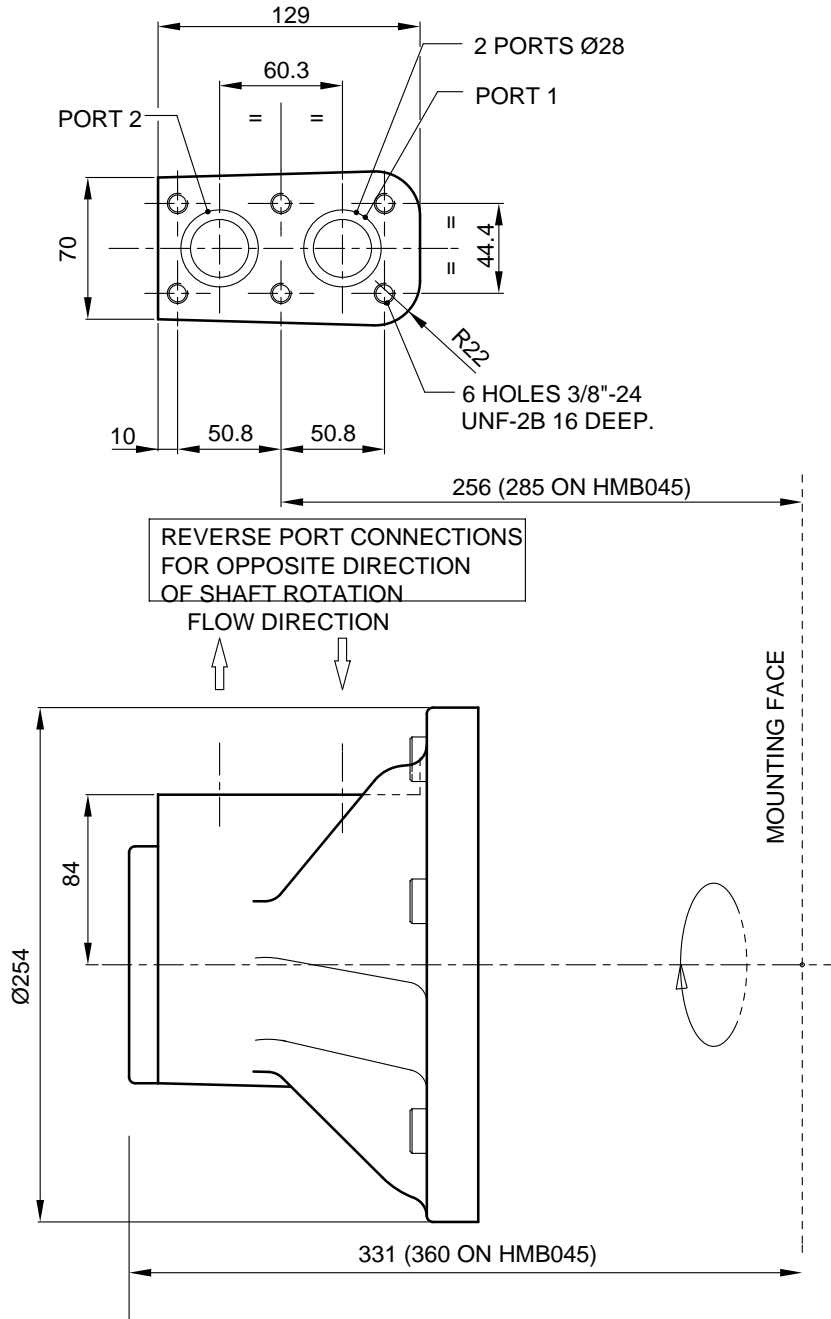

Model Staffa

Page 39.70

Data Sheet M-1001/03.00



HMB030/HMB045 Valve Housings (continued)

1" SAE 4-BOLT FLANGE, 'F2'/'FM2'

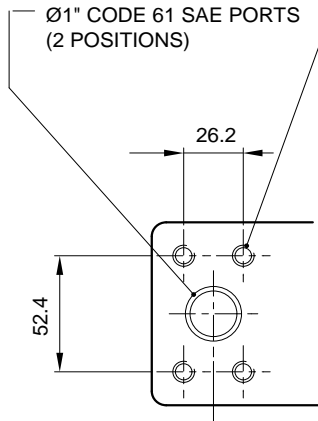

Ø1" CODE 61 SAE PORTS
(2 POSITIONS)

4 HOLES (2 POSITIONS) SEE
TABLE FOR BOLT TAPPINGS

PORT FLANGE BOLT TAPPINGS

MODEL CODE	TAPPING SIZE
F2	3/8"-16 UNC-2B X 22 FULL THREAD DEPTH
FM2	M10 X P1.5 X 22 FULL THREAD DEPTH

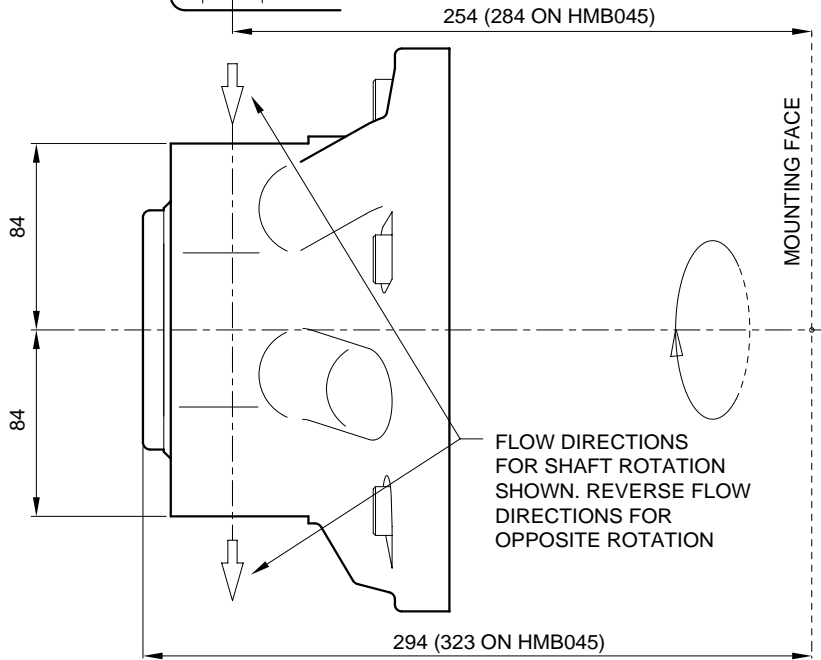

FLOW DIRECTIONS
FOR SHAFT ROTATION
SHOWN. REVERSE FLOW
DIRECTIONS FOR
OPPOSITE ROTATION



Installation Drawings

HMB060/80 motors with type "F3"/"FM3" (1 1/4" SAE) port connection

See additional views for shaft types and for types "S03" and "S04" port connection.
See drawing of dual-mount model for details of types "F2" and FM2" port connection.

PORT FLANGE BOLT TAPPINGS

MODEL CODE	TAPPING SIZE	GAUGE CONNECTIONS
F3	7/16"-14 UNC-2B X 27 FULL THREAD DEPTH	9/16"-18 UNF-2B, SAE J475
FM3	M12 X P1.75 X 27 FULL THREAD DEPTH	G1/4" (BSPF)

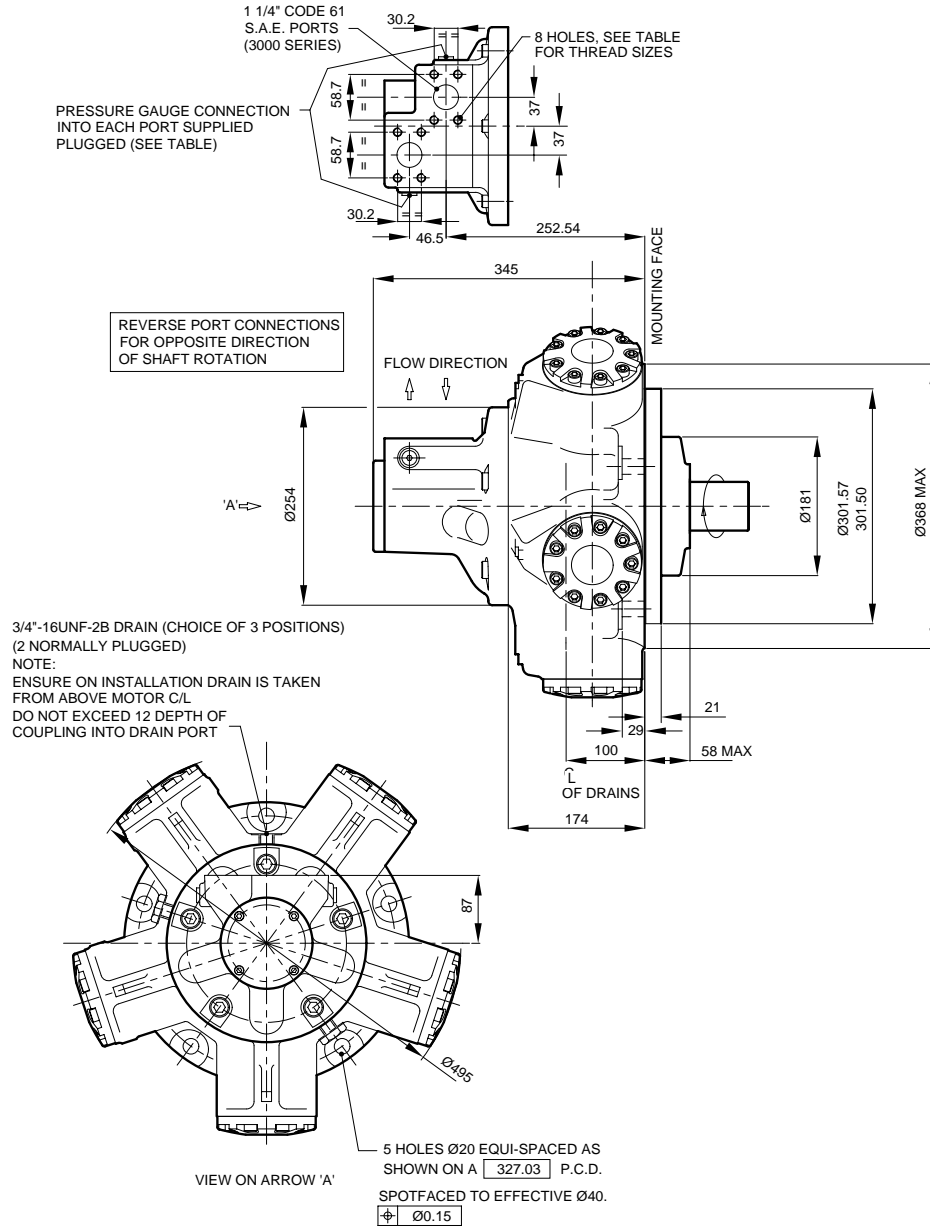

Model Staffa

Page 41.70

Data Sheet M-1001/03.00



HMB060/080/100 Shaft Specification

**SHAFT TYPES 'P' & 'HP'
CYLINDRICAL SHAFT WITH KEY**

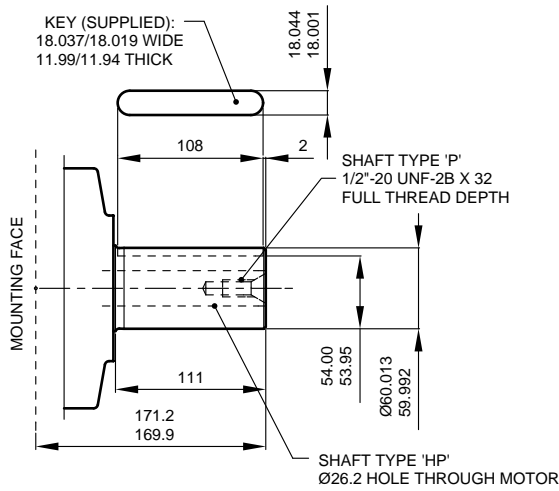

**SHAFT TYPE 'X'
SHORT TAPER WITH KEY**

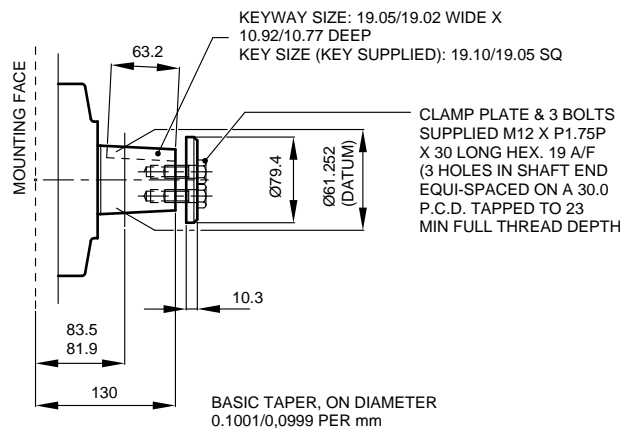

**SHAFT TYPE 'T'
LONG TAPER WITH KEY**

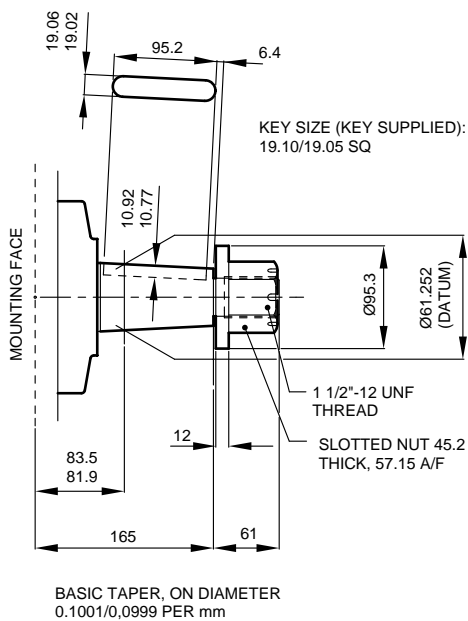

HMB060/080/100 Shaft Specification (continued)

SHAFT TYPES 'S' & 'HS'
14 SPLINES TO BS 3550-1963

SHAFT TYPES 'Z' & 'HZ'
22 SPLINES TO DIN 5480

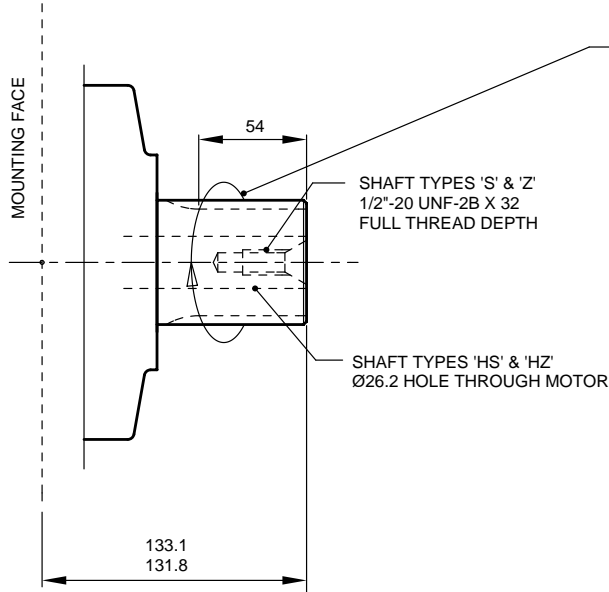

SPLINE DATA

FOR SHAFT TYPES 'S' & 'HS'
TO BS 3550/ANSI B92.1 1970 CLASS 5
FLAT ROOT SIDE FIT, CLASS 1

PRESSURE ANGLE	30°
NUMBER OF TEETH	14
PITCH	6/12
MAJOR DIAMETER	62.553/62.425
FORM DIAMETER	55.052
MINOR DIAMETER	54.084/53.525
PIN DIAMETER	8.128
DIAMETER OVER PINS	71.593/71.544

FOR SHAFT TYPES 'Z' & 'HZ'
DIN 5480 W70 X 3 X 30 X 22 X 7h

SHAFT TYPE 'Q' & 'HQ'
FEMALE SHAFT WITH 24 SPLINES TO BS 3550

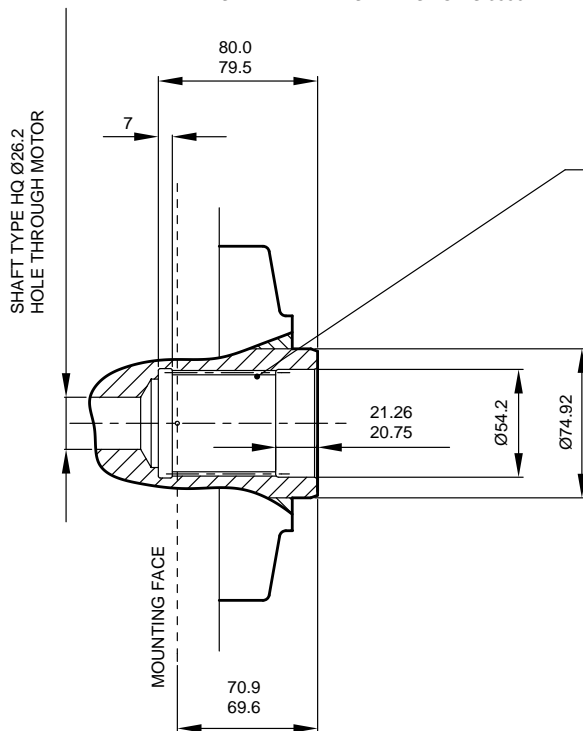

SPLINE DATA

TO BS 3550
FLAT ROOT SIDE FIT, MODIFIED

PRESSURE ANGLE	30°
NUMBER OF TEETH	24
PITCH	12/24
MAJOR DIAMETER	53.246/52.916
MINOR DIAMETER	48.811/48.684
PIN DIAMETER	3.658
PIN FLATTED TO	3.560
DIAMETER BETWEEN PINS	45.626/45.550



Model
Staffa

Page
43.70

Data Sheet
M-1001/03.00



Installation Drawings
HMB125 Motor with type "F3"/FM3 (1 1/4" SAE) Port Connection

SEE VIEWS FOR SHAFT TYPES & 'F2', 'FM2', 'S03', 'S04', 'F4' & 'FM4' PORT CONNECTION.

PORT FLANGE BOLT TAPPINGS

MODEL CODE	TAPPING SIZE	GAUGE CONNECTIONS
F3	7/16"-14 UNC-2B X 27 FULL THREAD DEPTH	9/16"-18 UNF-2B, SAE J475
FM3	M12 X P1.75 X 27 FULL THREAD DEPTH	G1/4" (BSPF)

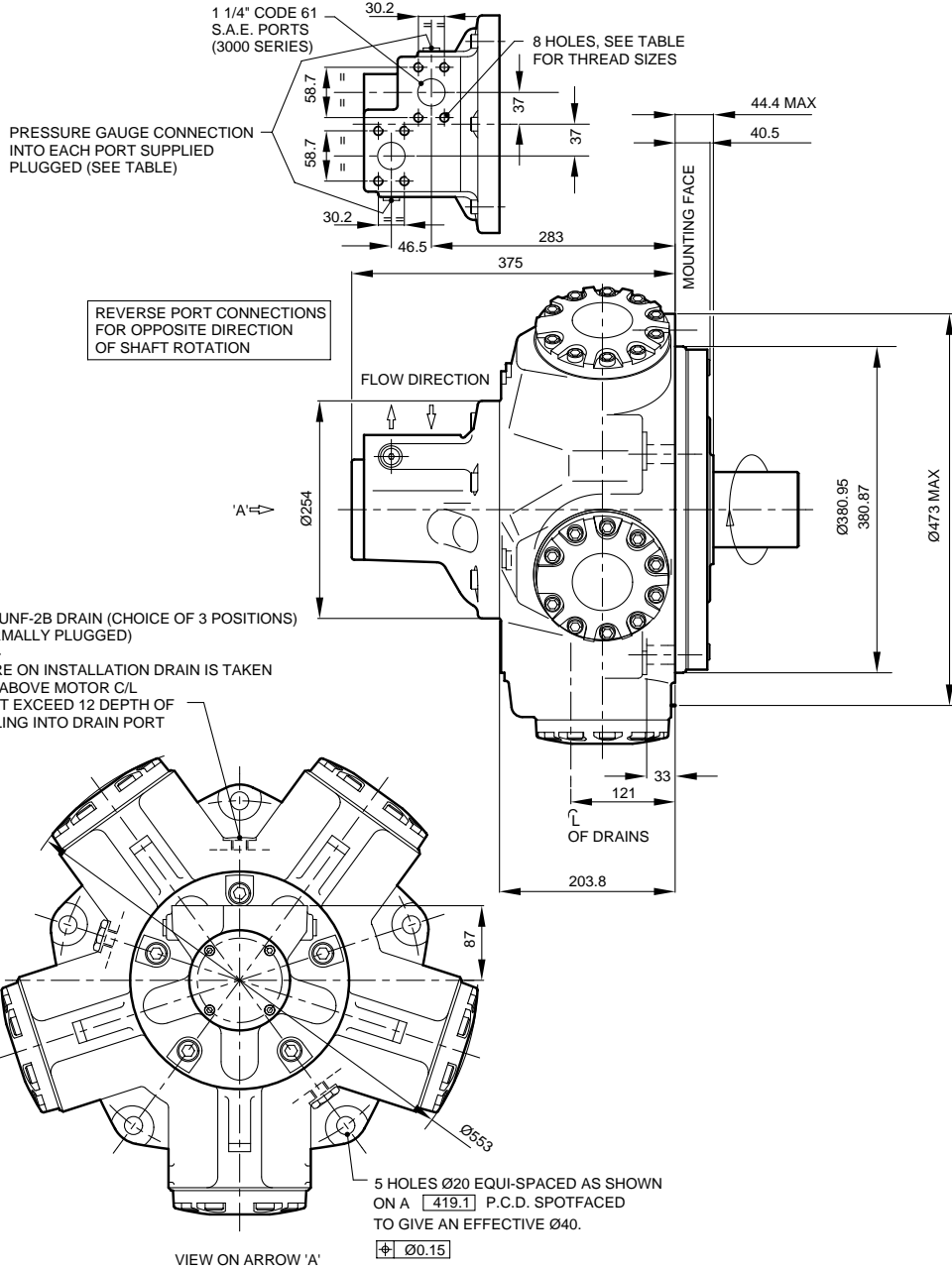

Installation Drawings HDB125 Motor with type "F3"/FM3 (1 1/4" SAE) Port Connection

SEE VIEWS FOR SHAFT TYPES & 'F2', 'FM2', 'S03', 'S04', 'F4' & 'FM4' PORT CONNECTION.

PORT FLANGE BOLT TAPPINGS

MODEL CODE	TAPPING SIZE	GAUGE CONNECTIONS
F3	7/16"-14 UNC-2B X 27 FULL THREAD DEPTH	9/16"-18 UNF-2B, SAE J475
FM3	M12 X P1.75 X 27 FULL THREAD DEPTH	G1/4" (BSPF)

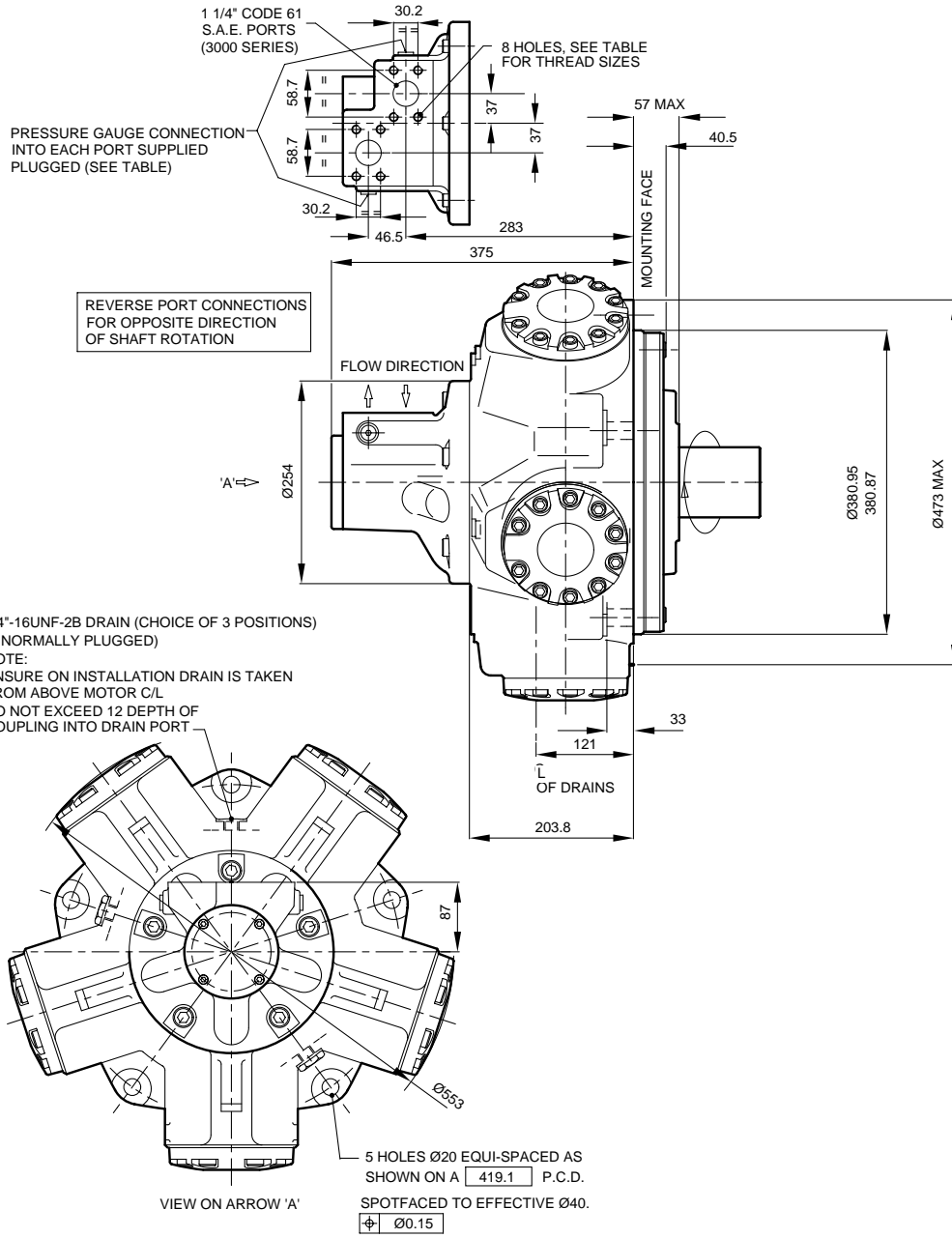

Model Staffa

Page 45.70

Data Sheet M-1001/03.00



Motor HMB125 Shaft Specification

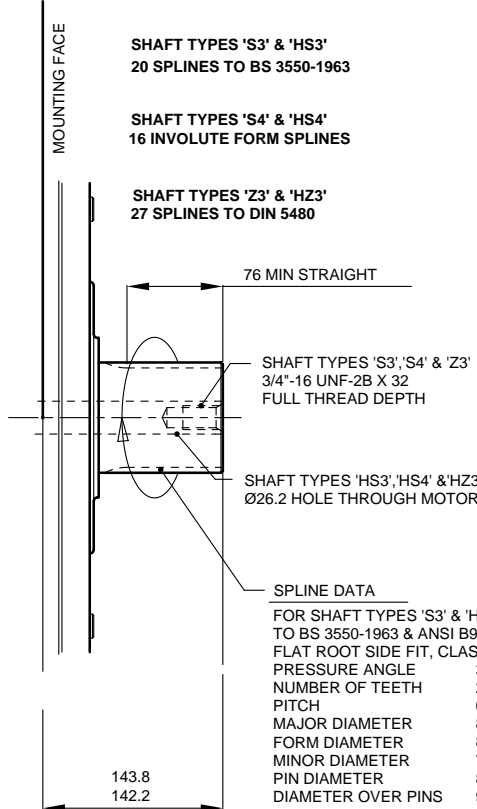

FOR SHAFT TYPES 'Z3' & 'HZ3'
DIN 5480 W85 X 3 X 27 X 7H

**SHAFT TYPE 'T'
LONG TAPER WITH KEY**

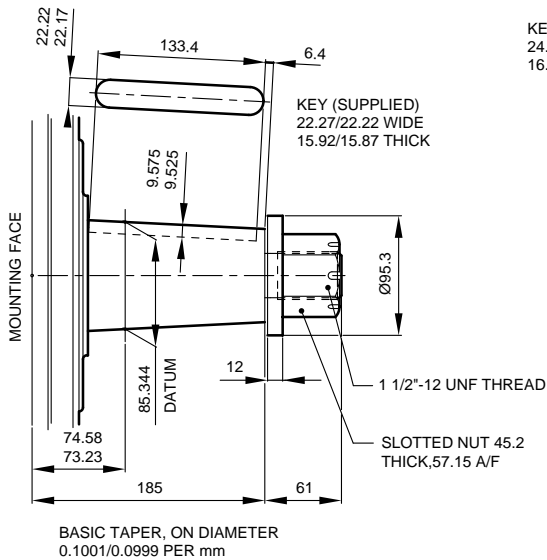

**SHAFT TYPES 'P1' & 'HP1'
CYLINDRICAL SHAFT WITH KEY**

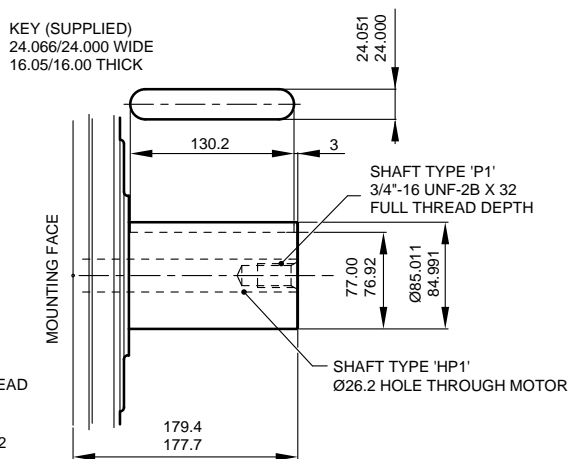

Motor HDB125 Shaft Specification

SHAFT TYPES 'S5' & 'HS5'
23 SPLINES TO BS 3550-1963

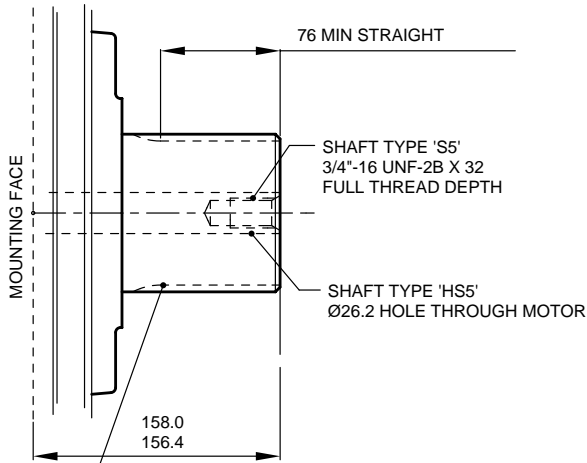

SPLINE DATA

FOR SHAFT TYPES 'S5' & 'HS5'
TO BS 3550-1963 & ASA.B5.15-1960
FLAT ROOT SIDE FIT, CLASS 1

PRESSURE ANGLE	30°
NUMBER OF TEETH	23
PITCH	6/12
MAJOR DIAMETER	100.652/100.526
FORM DIAMETER	92.939
MINOR DIAMETER	92.184/91.626
PIN DIAMETER	8.128
DIAMETER OVER PINS	109.573/109.517

SHAFT TYPES 'S3' & 'HS3'
20 SPLINES TO BS 3550-1963

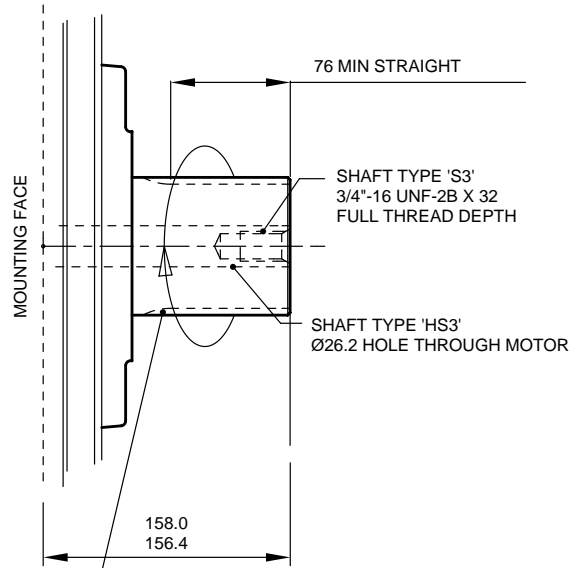

SPLINE DATA

FOR SHAFT TYPES 'S3' & 'HS3'
TO BS 3550-1963 & ASA.B5.15-1960
FLAT ROOT SIDE FIT, CLASS 1

PRESSURE ANGLE	30°
NUMBER OF TEETH	20
PITCH	6/12
MAJOR DIAMETER	87.953/87.825
FORM DIAMETER	80.264
MINOR DIAMETER	79.485/78.925
PIN DIAMETER	8.128
DIAMETER OVER PINS	97.084/97.030

SHAFT TYPES 'Z5' & 'HZ5'
24 SPLINES TO DIN 5480

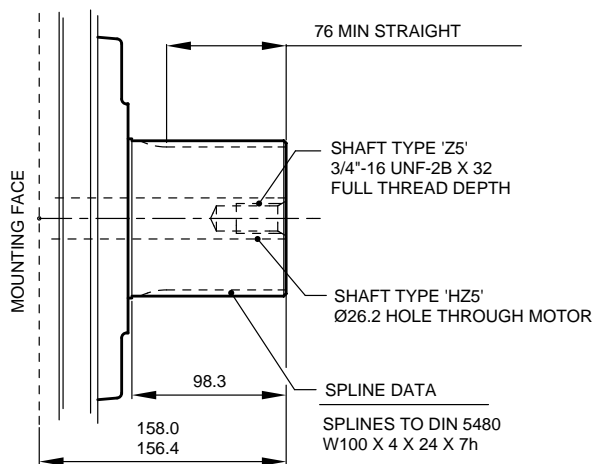

SPLINE DATA

SPLINES TO DIN 5480
W100 X 4 X 24 X 7h



Model Staffa

Page 47.70

Data Sheet M-1001/03.00



Motor HDB125 Shaft Specification (continued)

**SHAFT TYPES 'P1' & 'HP1'
CYLINDRICAL SHAFT WITH KEY**

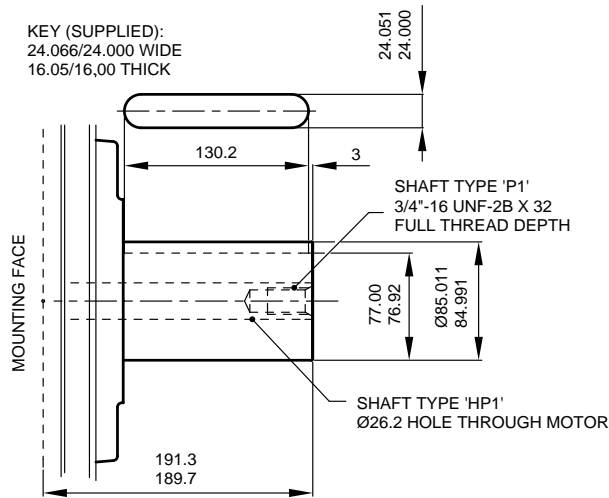

**SHAFT TYPE 'Q' & 'HQ'
FEMALE SHAFT WITH 34 SPLINES TO BS 3550**

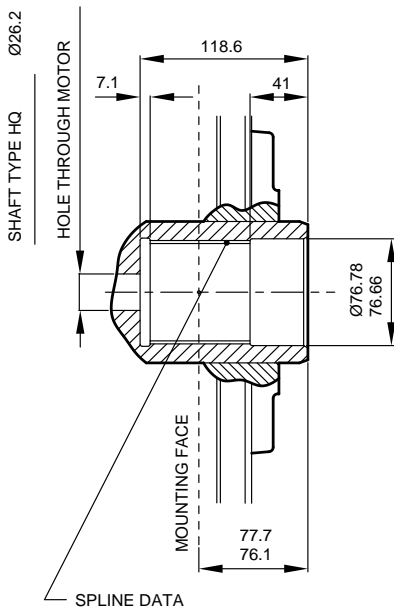

TO BS 3550-1963 & ASA,B5.15-1960	
FLAT ROOT SIDE FIT,	
PRESSURE ANGLE	30°
NUMBER OF TEETH	34
PITCH	12/24
MAJOR DIAMETER	74.414/74.084
MINOR DIAMETER	69.977/69.850
PIN DIAMETER	3.658
PIN FLATTED TO	3.556
DIAMETER BETWEEN PINS	66.815/66.744

**SHAFT TYPES 'P2' & 'HP2'
CYLINDRICAL SHAFT WITH KEY**

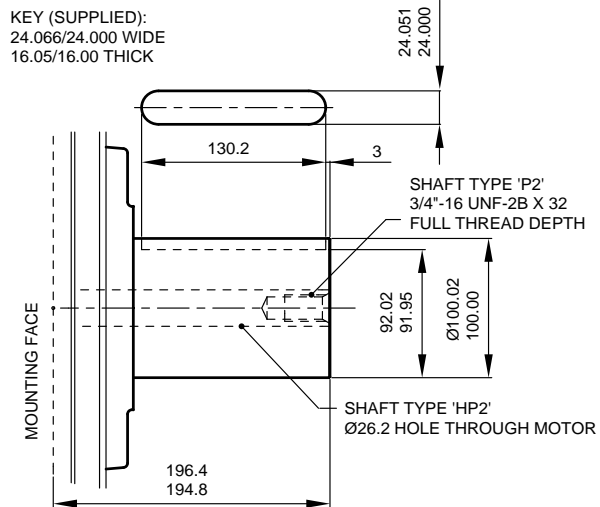

Motor HDB125 Shaft Specification (continued)

**SHAFT TYPE 'X' & 'HX'
SHORT TAPER WITH KEY**

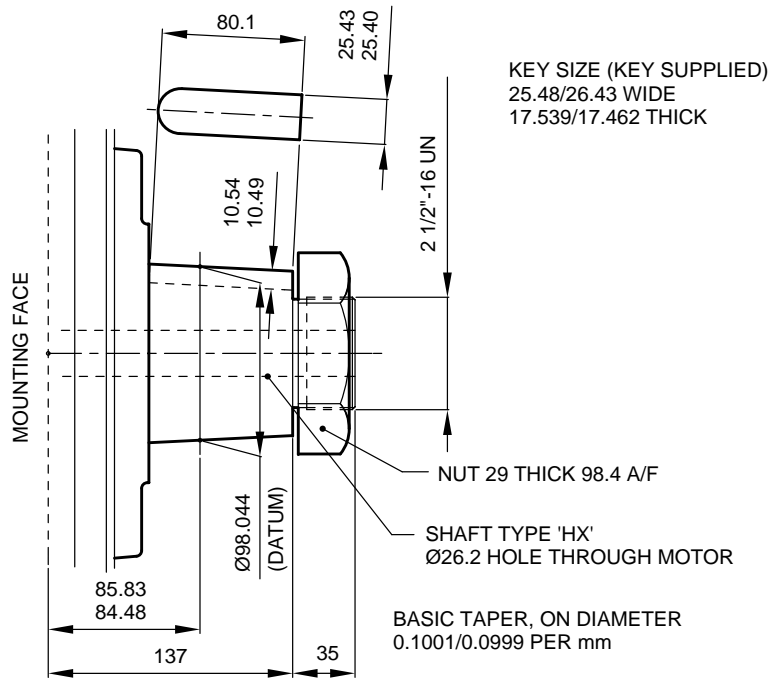

**SHAFT TYPE 'T'
LONG TAPER WITH KEY**

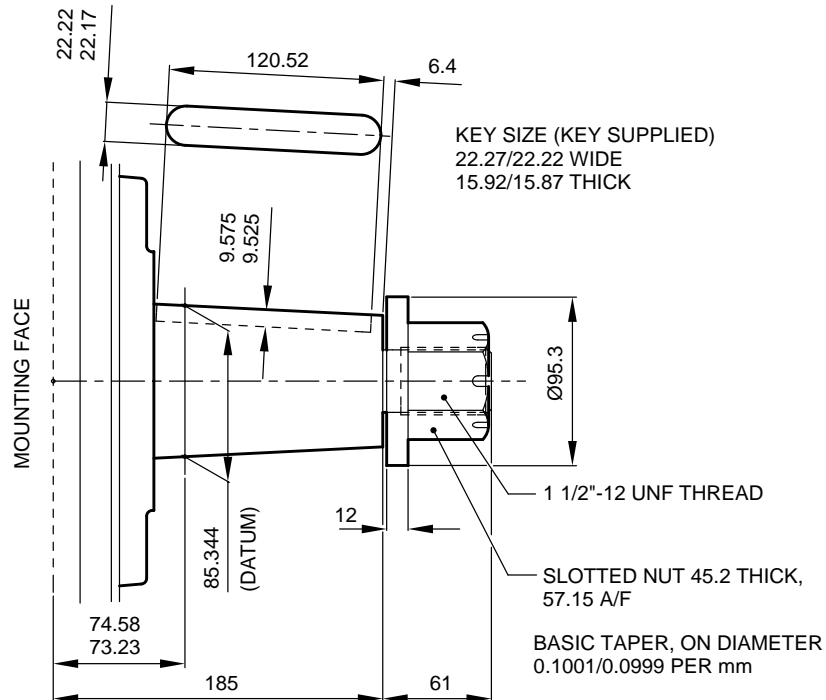

Model
Staffa

Page
49.70

Data Sheet
M-1001/03.00



Motor HMB125/HDB125 Valve Housings

**3" VALVE HOUSING WITH 6-BOLT FLANGE, 'S03'
SUPPLIED WITH 2 'O' RING SEALS**

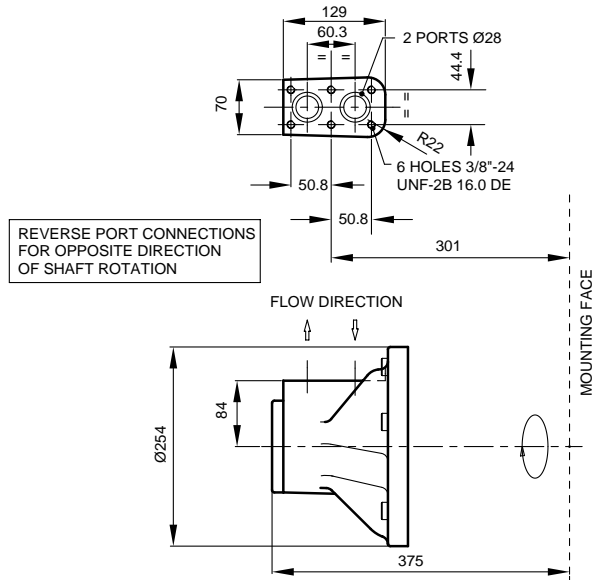

4" VALVE HOUSING WITH 1 1/2" SAE 4-BOLT FLANGES, 'F4'/FM4'

IN MODEL CODE POSITION **[4]**

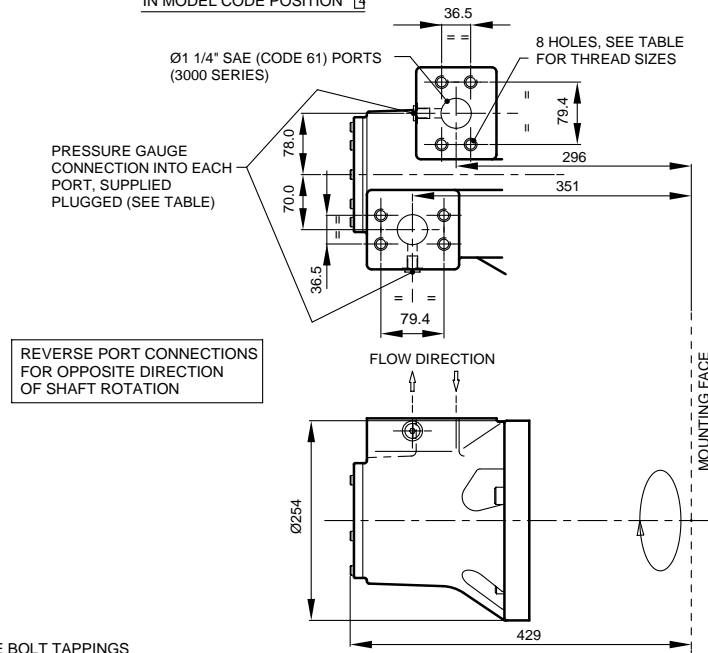

PORT FLANGE BOLT TAPPINGS

MODEL CODE	TAPPING SIZE	GAUGE CONNECTIONS
F4	5/8"-11 UNC-2B X 35 FULL THREAD DEPTH	9/16"-18 UNF-2B, SAE J475
FM4	M16 X P2 X 35 FULL THREAD DEPTH	G1/4" (BSPF)



Motor HMB125/HDB125 Valve Housings (continued)

**4" VALVE HOUSING WITH 6-BOLT FLANGE, 'S04'
SUPPLIED WITH 2 'O' RING SEALS**

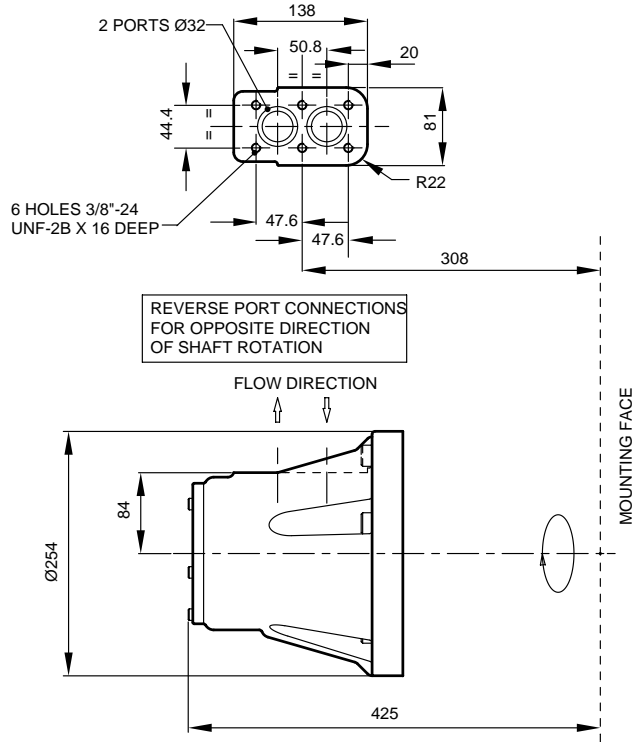

**2 1/4" VALVE HOUSING WITH 1" SAE 4-BOLT FLANGES,
F2'/FM2'**

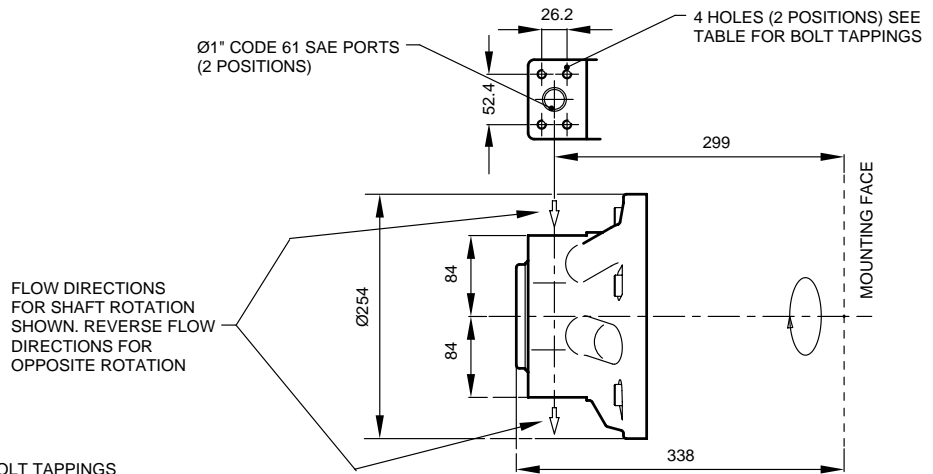

PORT FLANGE BOLT TAPPINGS

MODEL CODE	TAPPING SIZE
F2	3/8"-16 UNC-2B X 22 FULL THREAD DEPTH
FM2	M10 X P1.5 X 22 FULL THREAD DEPTH



Model Staffa

Page 51.70

Data Sheet M-1001/03.00



Installation Drawings

HMB150/200 Motors with type "F4"/"FM4" (1½" SAE) port connection

See additional views for shaft types and for types "S04", "F3", "FM3" and "S03" port connection

PORT FLANGE BOLT TAPPINGS

MODEL CODE	TAPPING SIZE	GAUGE CONNECTIONS
F4	5/8"-11 UNC-2B X 35 FULL THREAD DEPTH	9/16"-18 UNF-2B, SAE J475
FM4	M16 X P2.0 X 35 FULL THREAD DEPTH	G1/4" (BSPF)

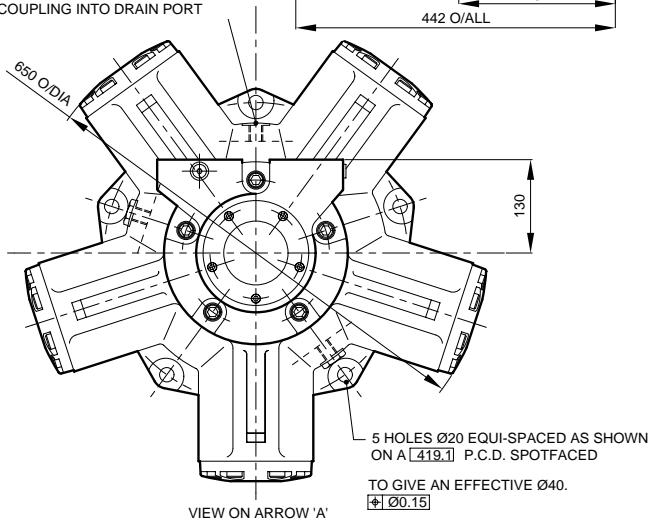
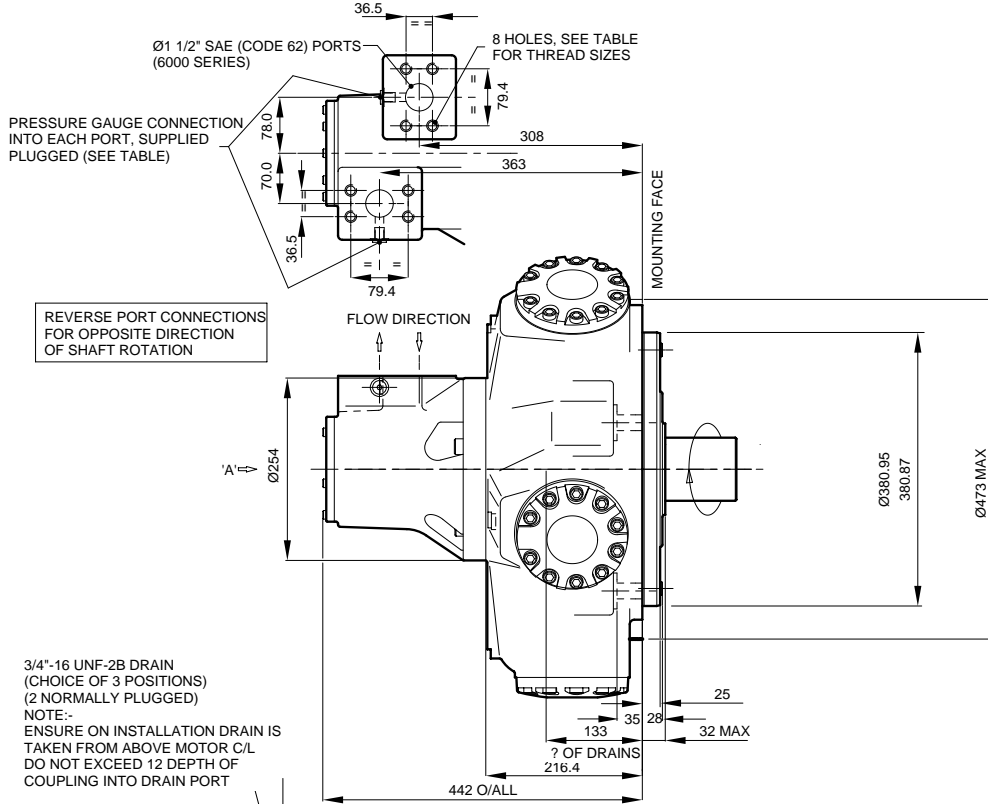

Installation Drawings

HMHDB 150/200 Motors with type "F4"/...(1 1/2" SAE) Port Connection

SEE VIEWS FOR SHAFT TYPES & 'F2', 'FM2', 'F3', 'FM3', 'S03' & 'S04' PORT CONNECTION.

PORT FLANGE BOLT TAPPINGS

MODEL CODE	TAPPING SIZE	GAUGE CONNECTIONS
F4	5/8"-11 UNC-2B X 35 FULL THREAD DEPTH	9/16"-18 UNF-2B, SAE J475
FM4	M16 X P2.0 X 35 FULL THREAD DEPTH	G1/4" (BSPF)

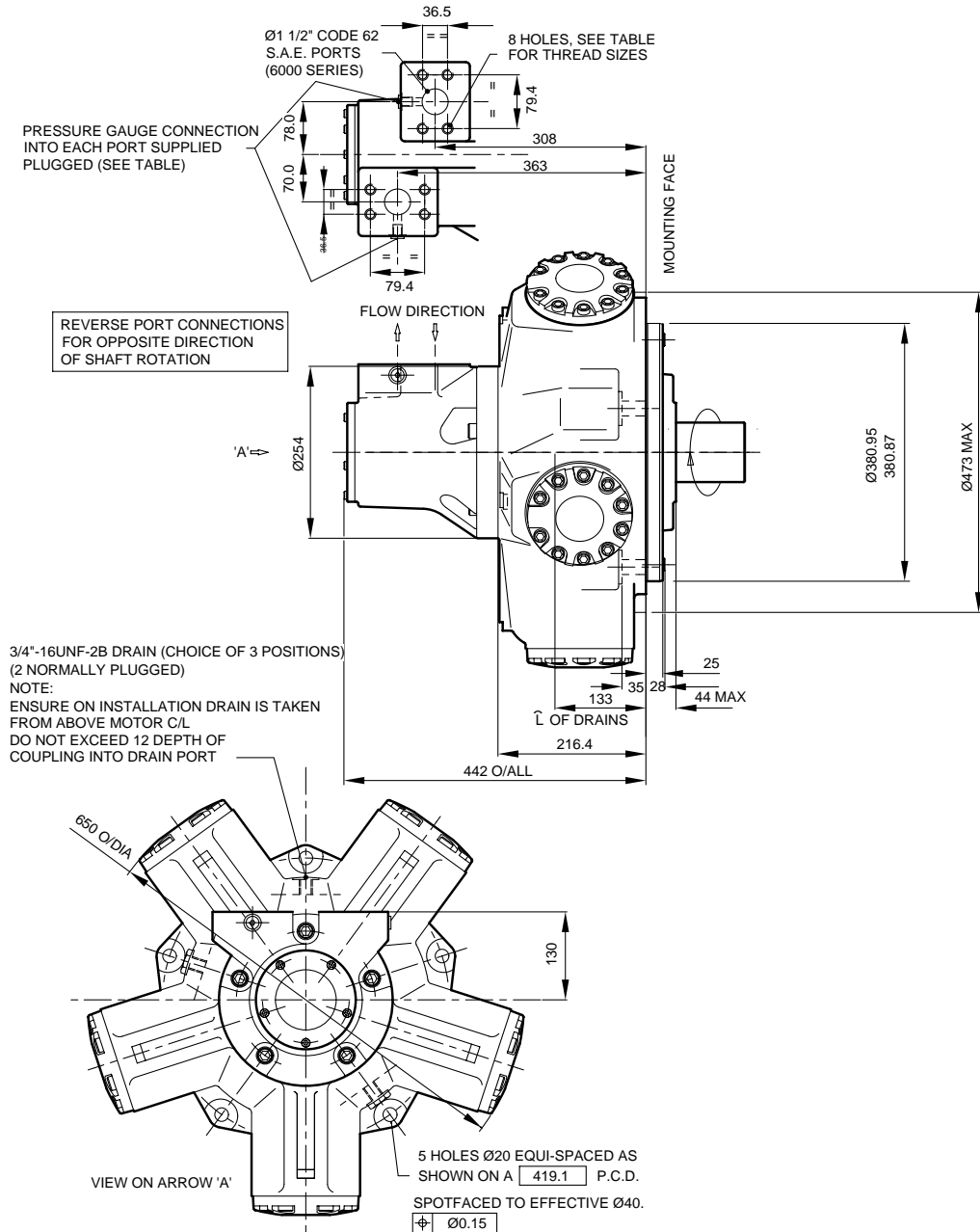

Model Staffa

Page 53.70

Data Sheet M-1001/03.00



HMB150 Shaft Specification

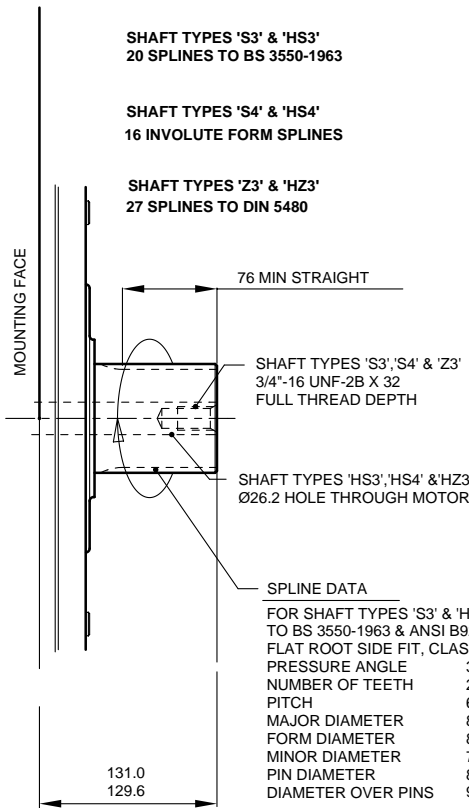

SPLINE DATA

FOR SHAFT TYPES 'S3' & 'HS3'
TO BS 3550-1963 & ANSI B92.1, 1970
FLAT ROOT SIDE FIT, CLASS 1
PRESSURE ANGLE 30°
NUMBER OF TEETH 20
PITCH 6/12
MAJOR DIAMETER 87.953/87.825
FORM DIAMETER 80.264
MINOR DIAMETER 79.485/78.925
PIN DIAMETER 8.128
DIAMETER OVER PINS 97.084/97.030

FOR SHAFT TYPES 'Z3' & 'HZ3'
DIN 5480 W85 X 3 X 27 X 7H

SPLINE DATA

FOR SHAFT TYPES 'S4' & 'HS4'
INVOLUTE GEAR TOOTH FORM

PRESSURE ANGLE	20°
NUMBER OF TEETH	16
PITCH	5/10
MAJOR DIAMETER	86.360/86.233
FORM DIAMETER	76.124
MINOR DIAMETER	74.93/72.39
PIN DIAMETER	8.636
DIAMETER OVER PINS	92.710/92.581

**SHAFT TYPE 'T'
LONG TAPER WITH KEY**

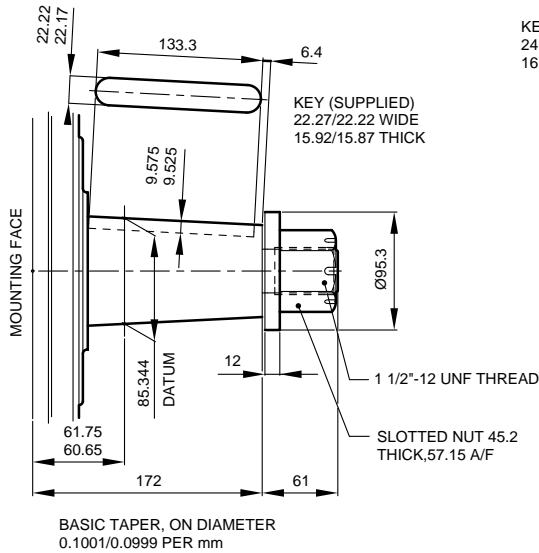

**SHAFT TYPES 'P1' & 'HP1'
CYLINDRICAL SHAFT WITH KEY**

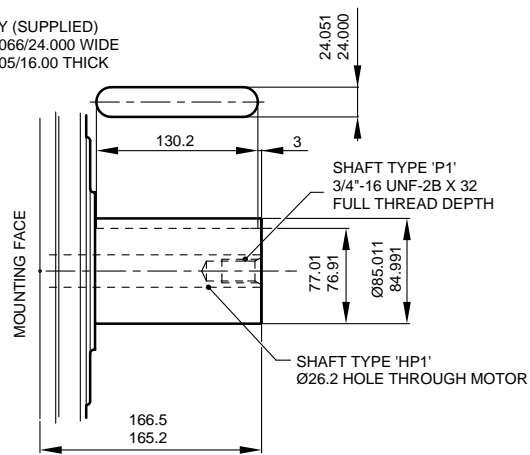

HDB 150/200 Shaft Specifications

SHAFT TYPES 'S5' & 'HS5'
23 SPLINES TO BS 3550-1963

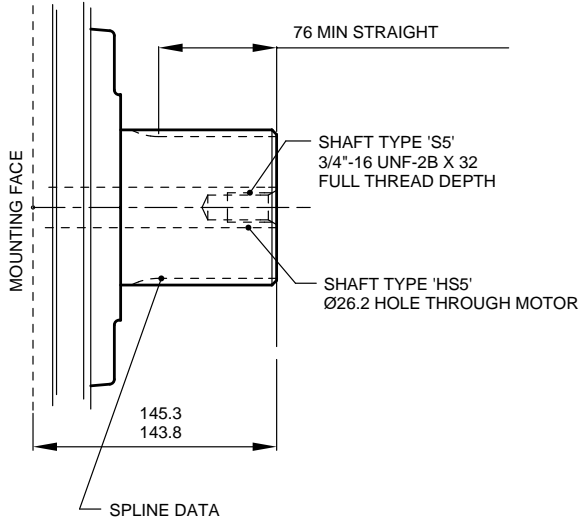

FOR SHAFT TYPES 'S5' & 'HS5'
TO BS 3550-1963 & ASA, B5.15-1960
FLAT ROOT SIDE FIT, CLASS 1
PRESSURE ANGLE 30°
NUMBER OF TEETH 23
PITCH 6/12
MAJOR DIAMETER 100.652/100.526
FORM DIAMETER 92.939
MINOR DIAMETER 92.184/91.626
PIN DIAMETER 8.128
DIAMETER OVER PINS 109.573/109.517

SHAFT TYPES 'S3' & 'HS3'
20 SPLINES TO BS 3550-1963

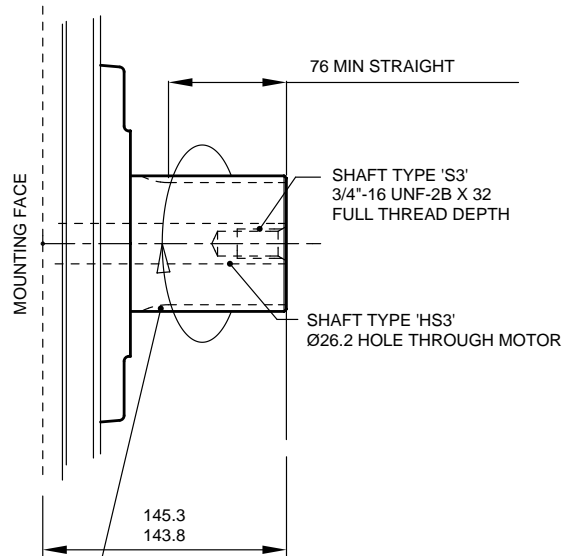

FOR SHAFT TYPES 'S3' & 'HS3'
TO BS 3550-1963 & ASA, B5.15-1960
FLAT ROOT SIDE FIT, CLASS 1
PRESSURE ANGLE 30°
NUMBER OF TEETH 20
PITCH 6/12
MAJOR DIAMETER 87.953/87.825
FORM DIAMETER 80.264
MINOR DIAMETER 79.485/78.925
PIN DIAMETER 8.128
DIAMETER OVER PINS 97.084/97.030

SHAFT TYPES 'Z5' & 'HZ5'
24 SPLINES TO DIN 5480

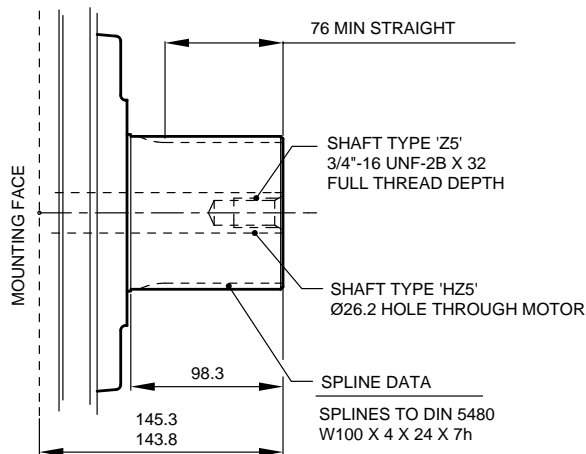

SPLINES TO DIN 5480
W100 X 4 X 24 X 7h



Model Staffa

Page 55.70

Data Sheet M-1001/03.00



HDB 150/200 Shaft Specifications (continued)

SHAFT TYPE 'Q' & 'HQ'
FEMALE SHAFT WITH 34 SPLINES TO BS 3550

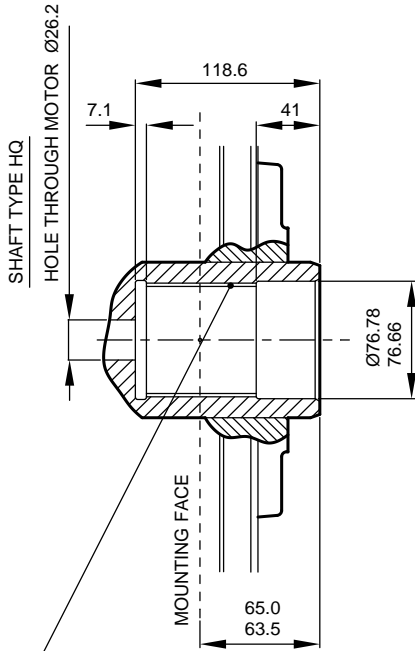

SPLINE DATA

TO BS 3550-1963 & ASA, B5.15-1960

FLAT ROOT SIDE FIT,	
PRESSURE ANGLE	30°
NUMBER OF TEETH	34
PITCH	12/24
MAJOR DIAMETER	74.414/74.084
MINOR DIAMETER	69.977/69.850
PIN DIAMETER	3.658
PIN FLATTED TO	3.556
DIAMETER BETWEEN PINS	66.815/66.744

SHAFT TYPES 'P2' & 'HP2'
CYLINDRICAL SHAFT WITH KEY

KEY (SUPPLIED):
 24.066/24.000 WIDE
 16.05/16.00 THICK

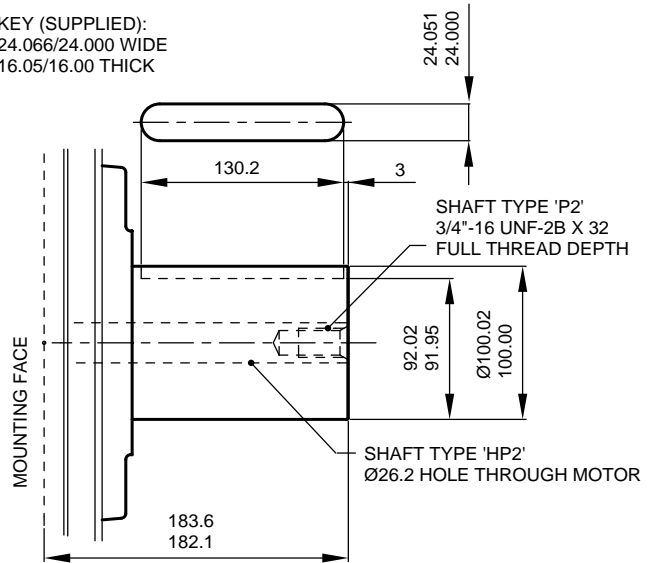

HDB 150/200 Shaft Specifications (continued)

SHAFT TYPE 'X' & 'HX'
SHORT TAPER WITH KEY

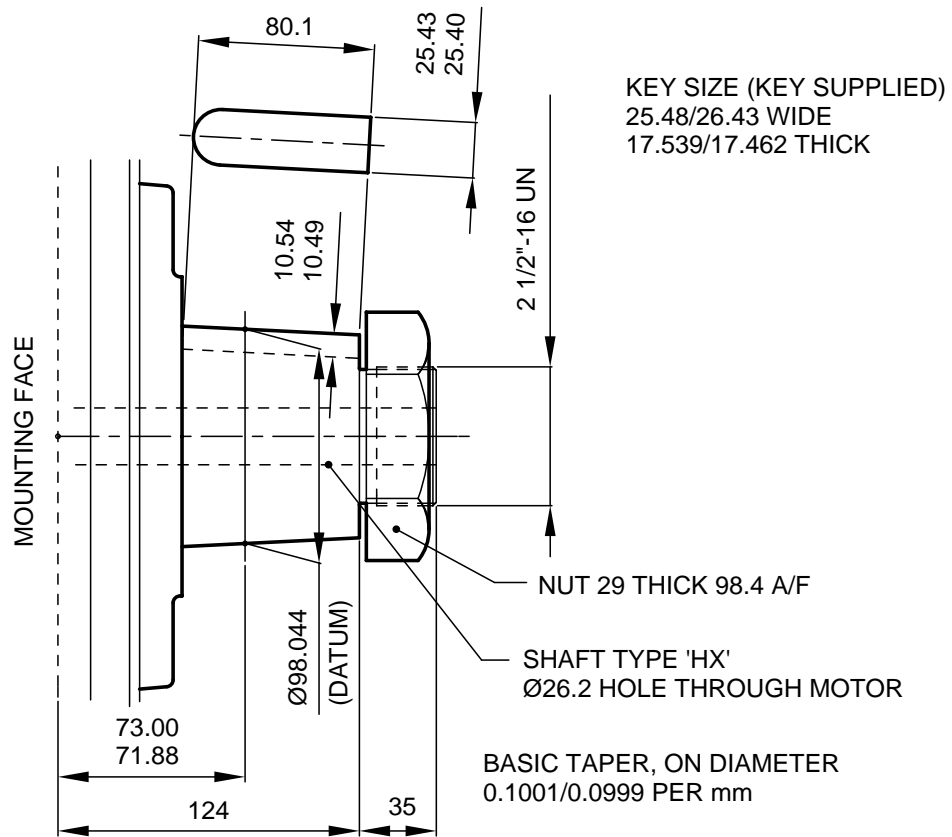

Model Staffa

Page 57.70

Data Sheet M-1001/03.00



HMB150/200 Valve Housings
3" Valve Housing with 6-Bolt Flange, "S03"

3" VALVE HOUSING WITH 6-BOLT FLANGE, 'S03'
 SUPPLIED WITH 2 'O' RING SEALS

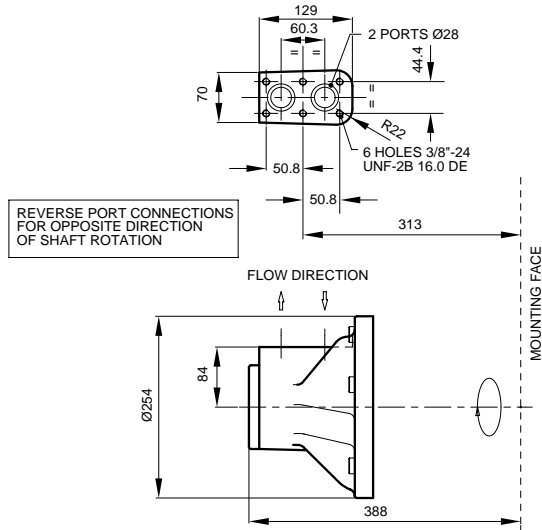

3" VALVE HOUSING WITH 1 1/4" SAE 4-BOLT FLANGES, 'F3'/FM3'

IN MODEL CODE POSITION 4

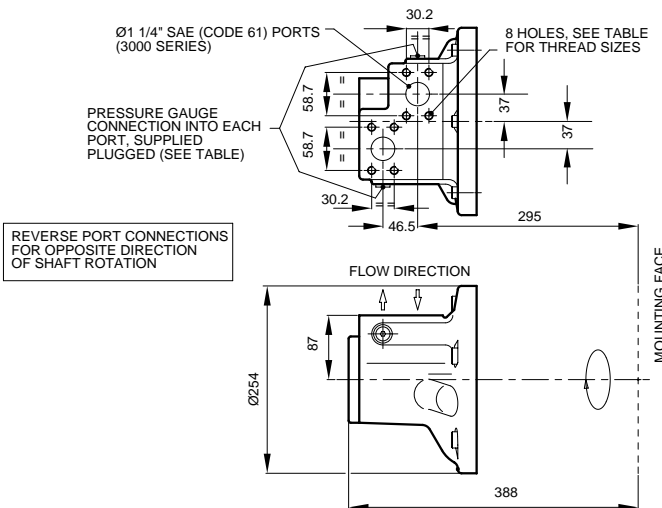

PORT FLANGE BOLT TAPPINGS

MODEL CODE	TAPPING SIZE	GAUGE CONNECTIONS
F3	7/16"-14 UNC-2B X 27 FULL THREAD DEPTH	9/16"-18 UNF-2B, SAE J475
FM3	M12 X R1.75 X 27 FULL THREAD DEPTH	G1/4" (BSPF)



Installation Drawings

HMB270 Motor with Type F4/FM4 (1 1/2 SAE) Port Connection (HMHDB270 Dimensions in brackets)

SEE ADDITIONAL VIEWS FOR SHAFT TYPES & 'SO4' PORT CONNECTION.

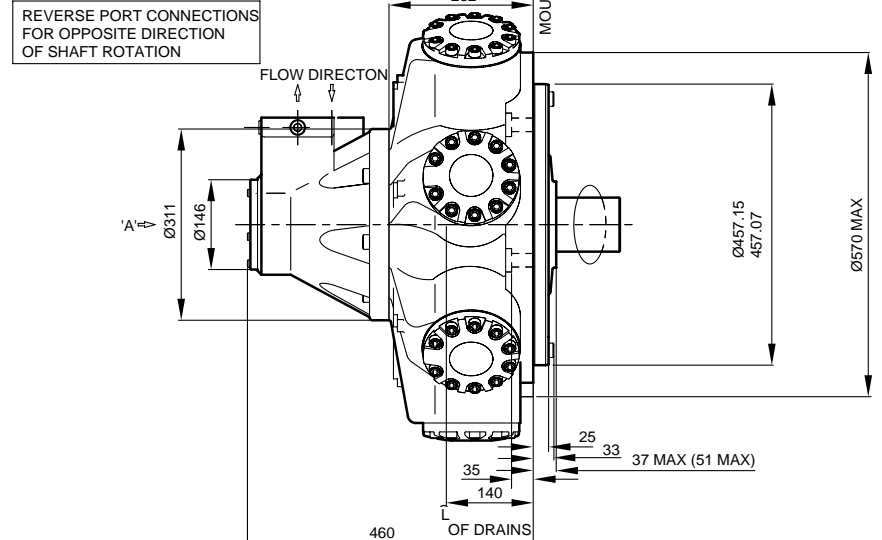
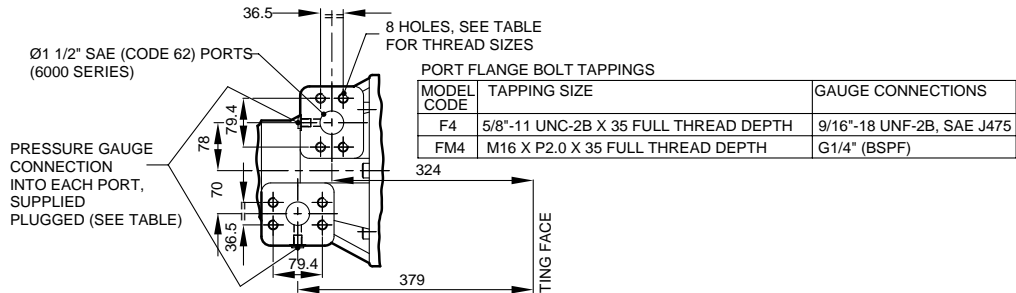

3/4"-16 UNF-2B DRAIN (CHOICE OF 3 POSITIONS)
 NOTE:-
 ENSURE ON INSTALLATION DRAIN IS TAKEN FROM ABOVE MOTOR C/L
 DO NOT EXCEED 12 DEPTH OF COUPLING INTO DRAIN PORT

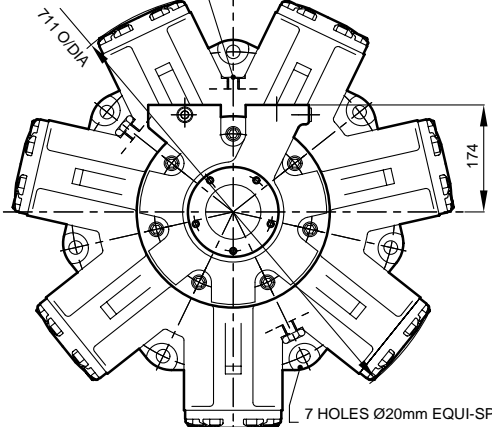

VIEW ON ARROW 'A' SPOTFACED TO GIVE EFFECTIVE Ø40
 Ⓢ0.13



Installation Drawings

HMDB 325 Motor with Type F4/FM4 (1 1/2" SAE) Port Connection HM325 (Dimensions in Brackets)

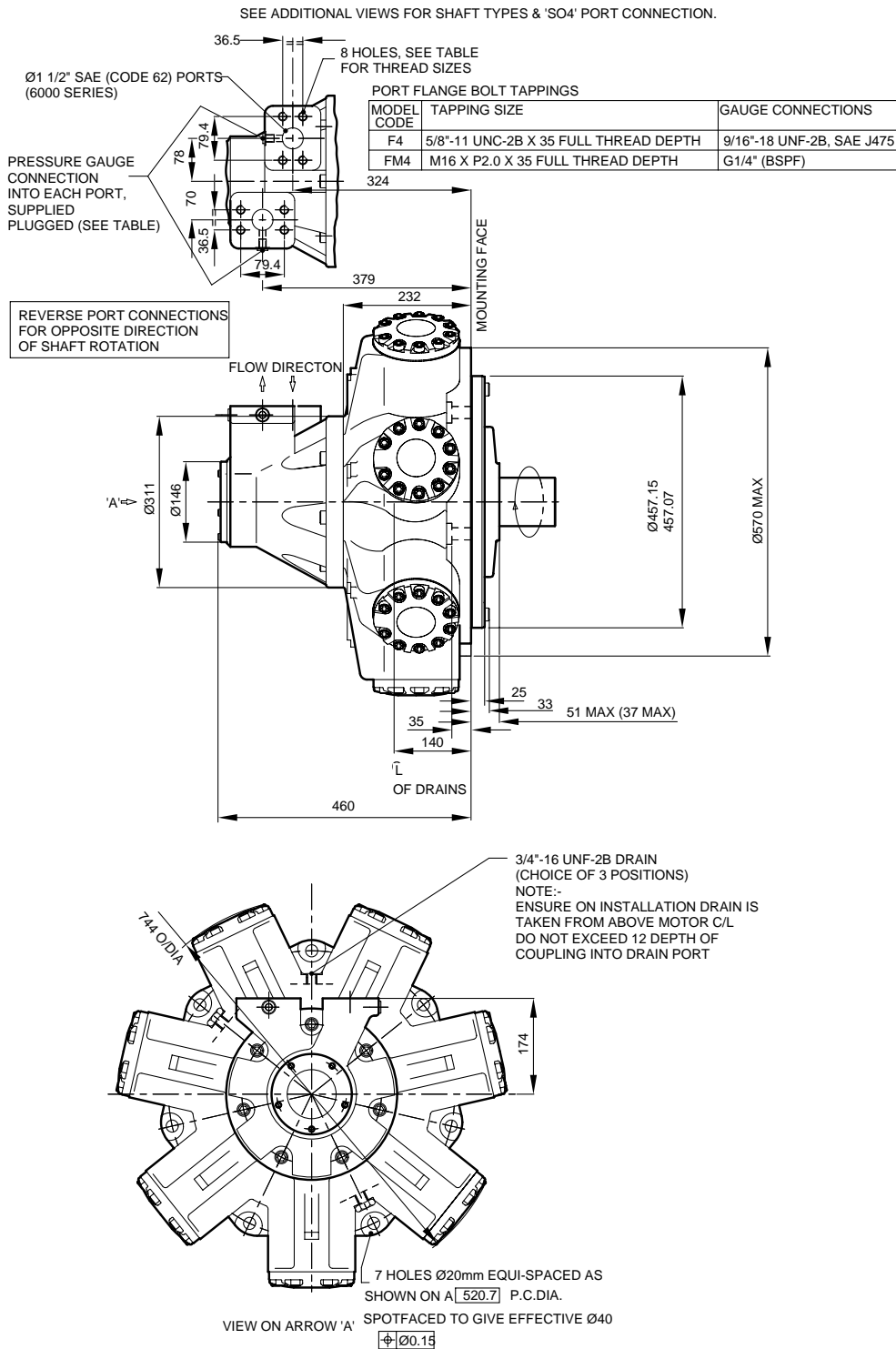

Model Staffa

Page 61.70

Data Sheet M-1001/03.00



HMB270/325 Shaft Specification

SHAFT TYPES 'S3' & 'HS3'
20 SPLINES TO BS 3550-1963

SHAFT TYPES 'Z' & 'HZ'
24 SPLINES TO DIN 5480

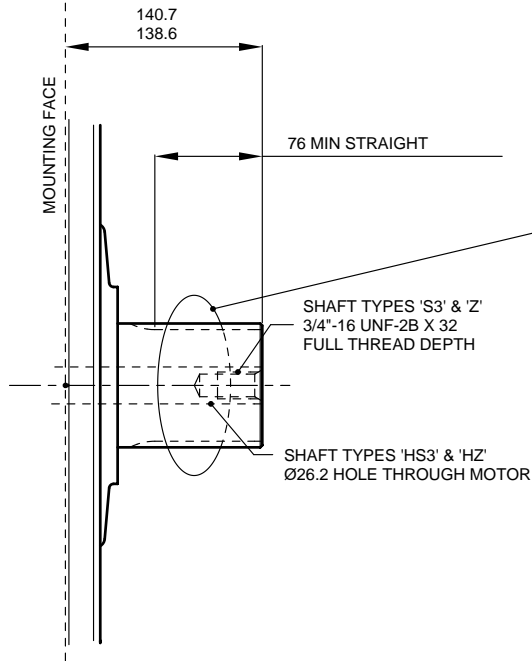

SPLINE DATA

FOR SHAFT TYPES 'S3' & 'HS3'
TO BS 3550-1963 (ANSI B92.1, 1970 CLASS 5)
FLAT ROOT SIDE FIT, CLASS 1
PRESSURE ANGLE 30 °
NUMBER OF TEETH 20
PITCH 6/12
MAJOR DIAMETER 87.953/87.825
FORM DIAMETER 80.264
MINOR DIAMETER 79.485/78.925
PIN DIAMETER 8.128
DIAMETER OVER PINS 97.084/97.030

FOR SHAFT TYPES 'Z' & 'HZ'
DIN 5480, W100 X 4 X 24 X 7h

SHAFT TYPE 'Q' & 'HQ'
FEMALE SHAFT WITH 34 SPLINES TO BS 3550

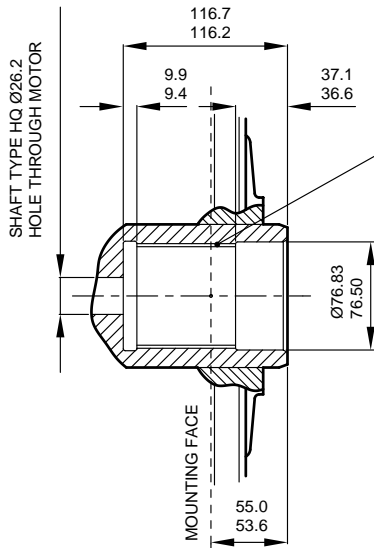

SPLINE DATA

TO BS 3550-1963
FLAT ROOT SIDE FIT
PRESSURE ANGLE 30 °
NUMBER OF TEETH 34
PITCH 12/24
MAJOR DIAMETER 74.414/74.084
MINOR DIAMETER 69.977/69.850
PIN DIAMETER 3.658
PIN FLATTED TO 3.556
DIMENSION BETWEEN PINS 66.815/66.744



HMB270/325 Shaft Specification (continued)

SHAFT TYPES 'P1' & 'HP1'
CYLINDRICAL SHAFT WITH KEY

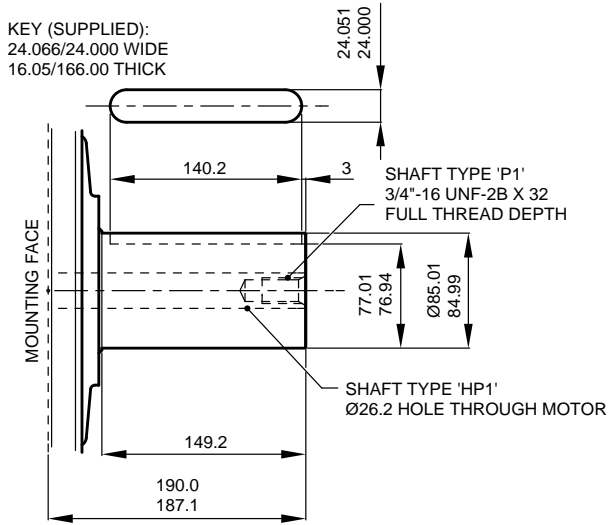

SHAFT TYPE 'T'
LONG TAPER WITH KEY

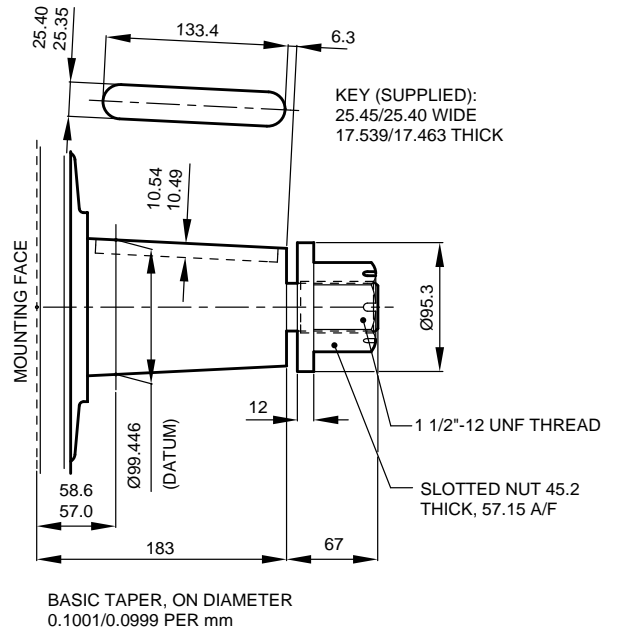

SHAFT TYPE 'X'
SHORT TAPER WITH 2 KEYS

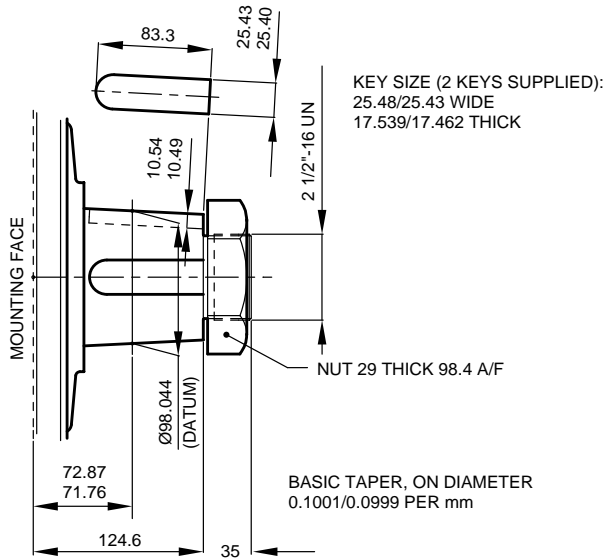

Model Staffa

Page 63.70

Data Sheet M-1001/03.00



HMHDB270/325 Shaft Specification

SHAFT TYPES 'Z' & 'HZ'
24 SPLINES TO DIN 5480

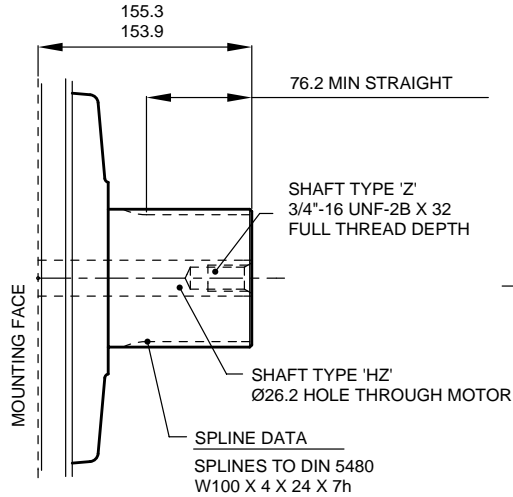

SHAFT TYPES 'S5' & 'HS5'
23 SPLINES TO BS 3550-1963

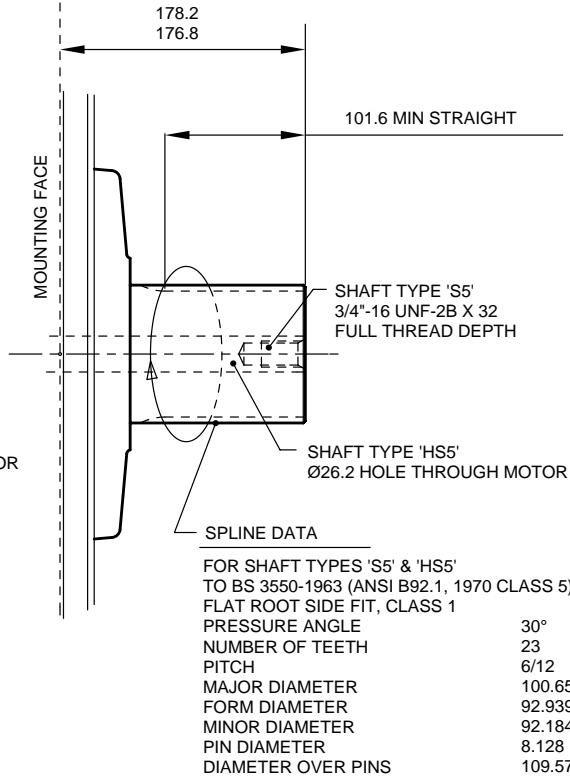

SHAFT TYPE 'X'
SHORT TAPER WITH 2 KEYS

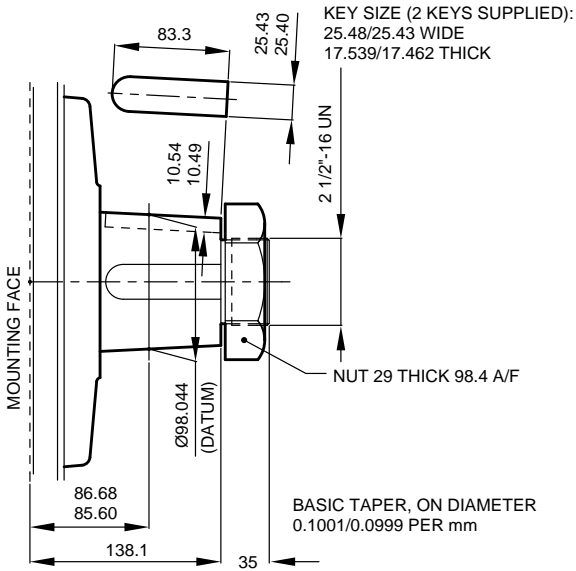

SHAFT TYPES 'P2' & 'HP2'
CYLINDRICAL SHAFT WITH KEY

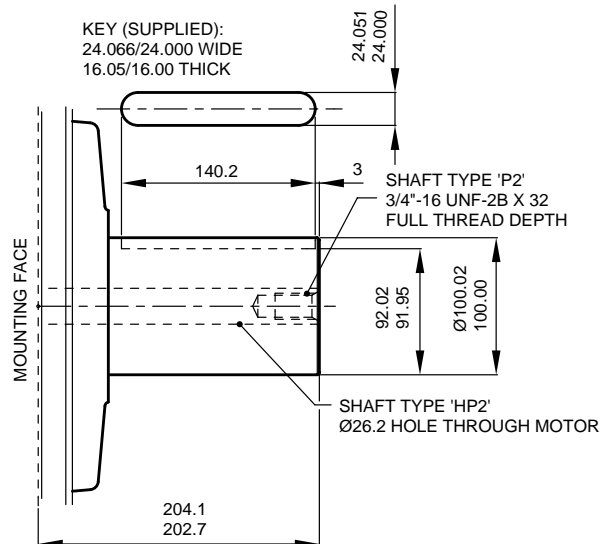

HMHDB270/325 Valve Housings
4" Valve Housing with 6-Bolt Flange, "S04"

SUPPLIED WITH 2 'O' RING SEALS

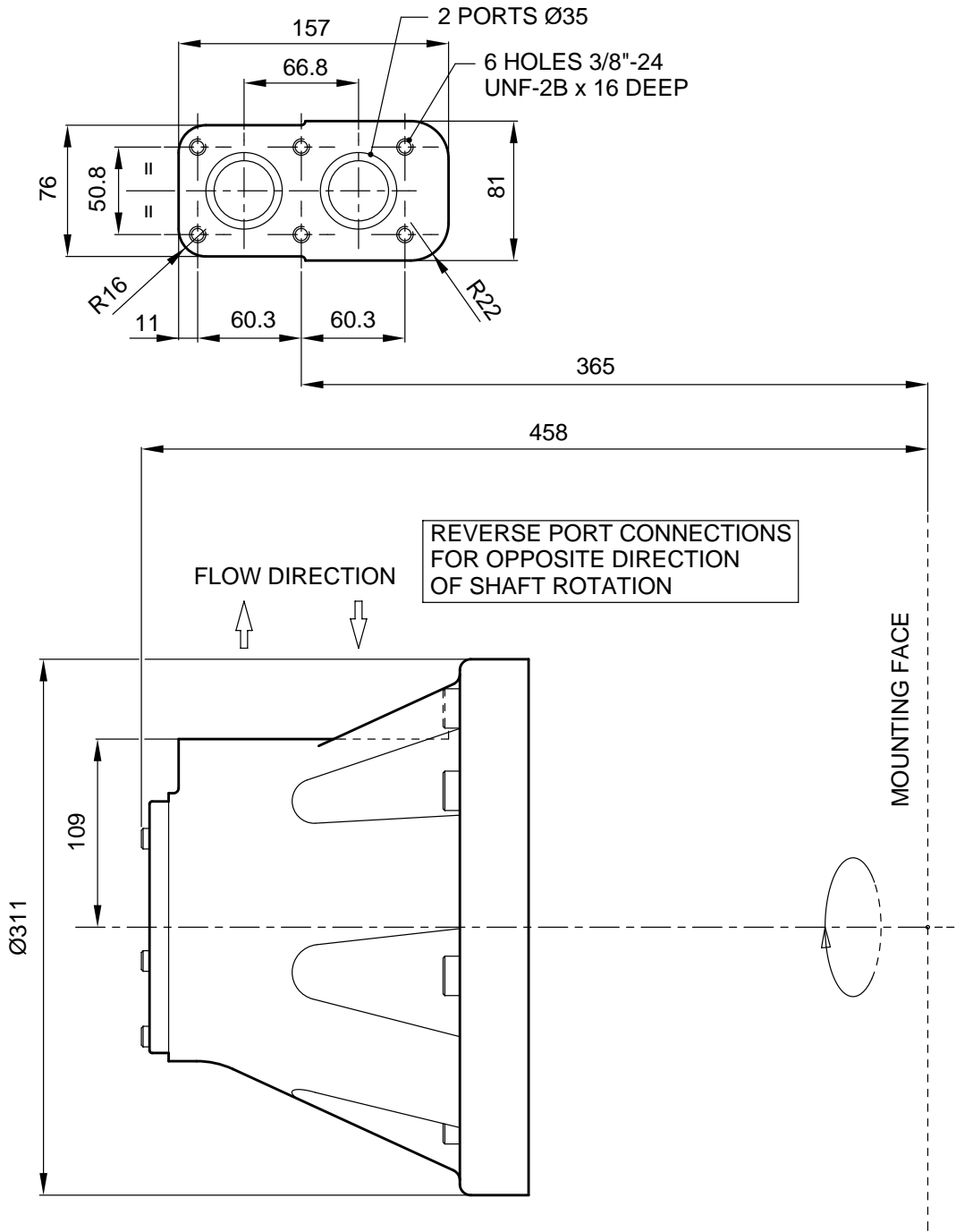

Model
Staffa

Page
65.70

Data Sheet
M-1001/03.00



Installation Drawings

HMHDB400 Motor with 6-Bolt (UNF) Flange or SAE 2", 4-Bolt (UNF) Flanges

HDB400 MOTOR WITH 6-BOLT (UNF) FLANGE OR SAE 2", 4-BOLT (UNF) FLANGES
SEE VIEWS FOR SHAFT TYPES & 'SO45' PORT CONNECTION.

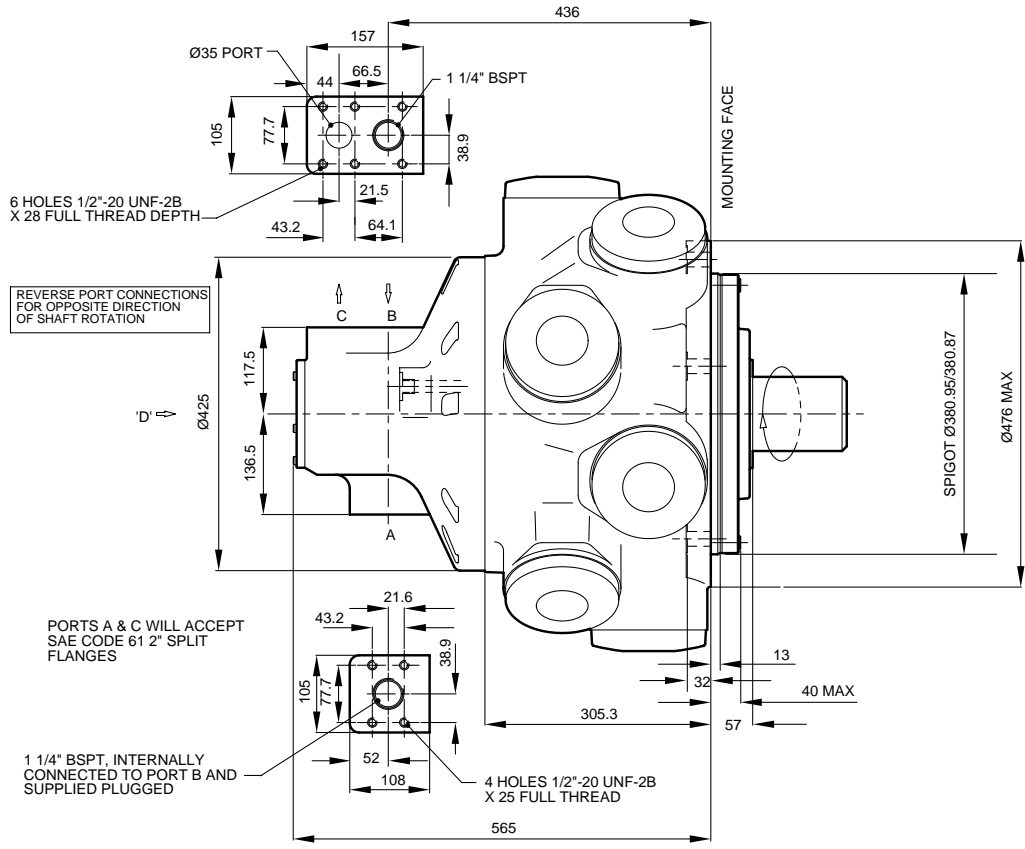

REVERSE PORT CONNECTIONS FOR OPPOSITE DIRECTION OF SHAFT ROTATION

PORTS A & C WILL ACCEPT SAE CODE 61 2" SPLIT FLANGES

1 1/4" BSPT, INTERNALLY CONNECTED TO PORT B AND SUPPLIED PLUGGED

2 DRAIN PORTS (1 NORMALLY PLUGGED) 3/4"-16 UNF-2B SPOTFACED TO Ø38

5 HOLES Ø20 EQUI-SPACED AS SHOWN ON A 419.1 PCD AND SPOTFACED TO Ø38

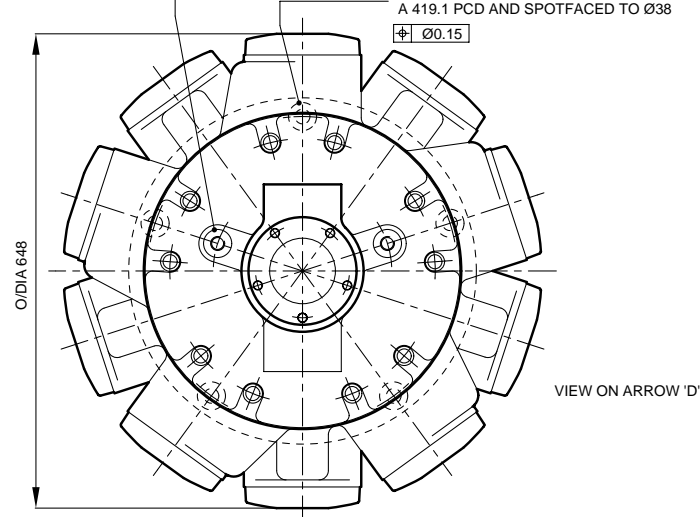

HMHDB400 Shaft Specification

SHAFT TYPE 'P'
CYLINDRICAL SHAFT WITH 2 KEYS

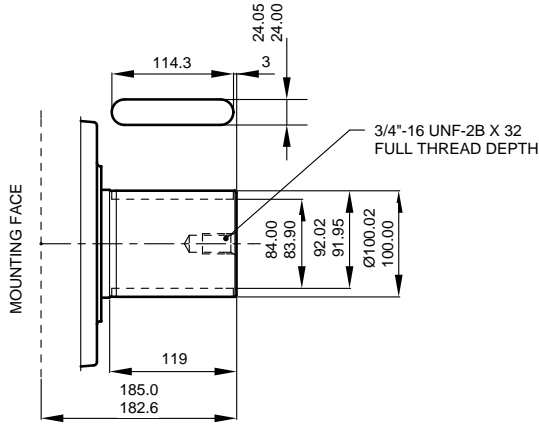

SHAFT TYPE 'S'
23 SPLINES TO BS 3550-1963

SHAFT TYPE 'Z'
24 SPLINES TO DIN 5480

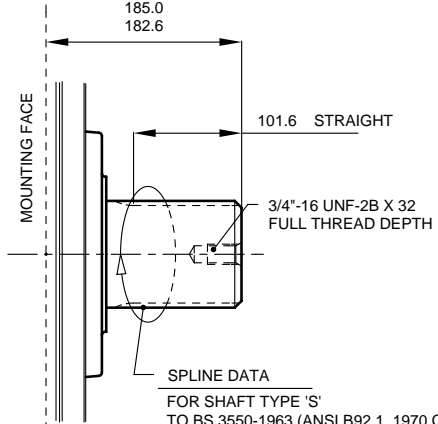

SPLINE DATA

FOR SHAFT TYPE 'S'
TO BS 3550-1963 (ANSI B92.1, 1970 CLASS 5)
FLAT ROOT SIDE FIT CLASS 1,
PRESSURE ANGLE 30°
NUMBER OF TEETH 23
PITCH 6/12
MAJOR DIAMETER 100.653/100.526
FORM DIAMETER 92.939
MINOR DIAMETER 92.184/91.625
PIN DIAMETER 8.128
DIAMETER OVER PINS 109.573/109.517

FOR SHAFT TYPE 'Z'
DIN 5480, W100 X 4 X 24 X 7h

SHAFT TYPE 'Q'
FEMALE SHAFT WITH 31 SPLINES TO BS 3550

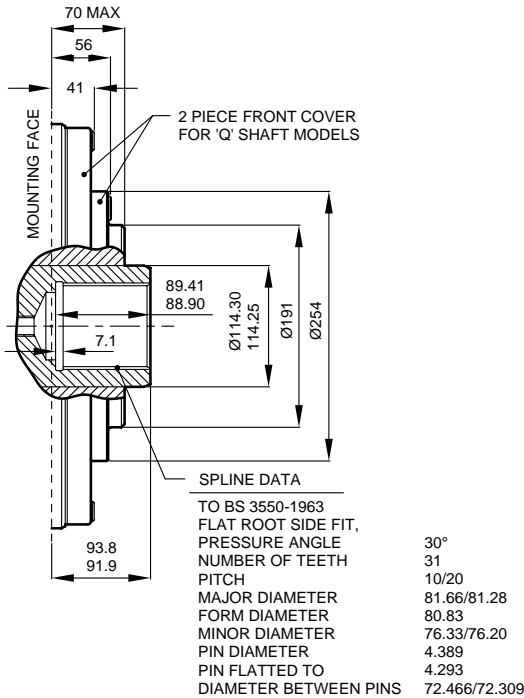

SPLINE DATA

TO BS 3550-1963
FLAT ROOT SIDE FIT,
PRESSURE ANGLE 30°
NUMBER OF TEETH 31
PITCH 10/20
MAJOR DIAMETER 81.66/81.28
FORM DIAMETER 80.83
MINOR DIAMETER 76.33/76.20
PIN DIAMETER 4.389
PIN FLATTED TO 4.293
DIAMETER BETWEEN PINS 72.466/72.309

SHAFT TYPE 'X'
SHORT TAPER WITH KEY

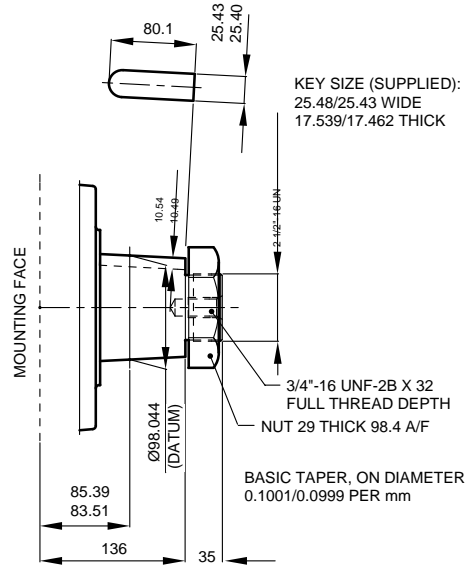

KEY SIZE (SUPPLIED):
25.48/25.43 WIDE
17.539/17.462 THICK

BASIC TAPER, ON DIAMETER
0.1001/0.0999 PER mm



Model Staffa

Page 67.70

Data Sheet M-1001/03.00



Installation Drawings
HMB700 Motor with 2 SAE (Code 62) Port
Flanges

SEE VIEWS FOR ADDITIONAL SHAFT TYPES.

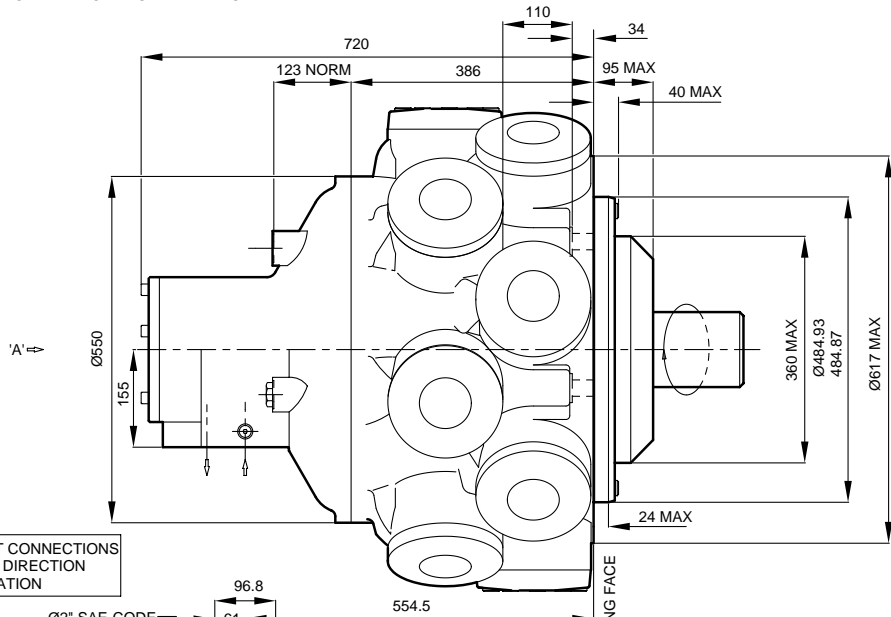

REVERSE PORT CONNECTIONS
 FOR OPPOSITE DIRECTION
 OF SHAFT ROTATION

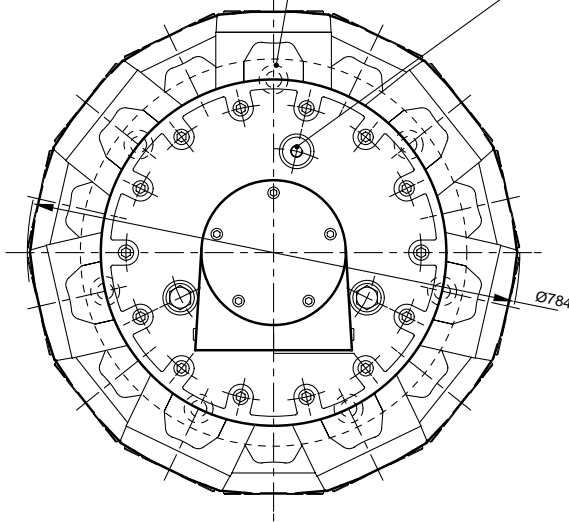
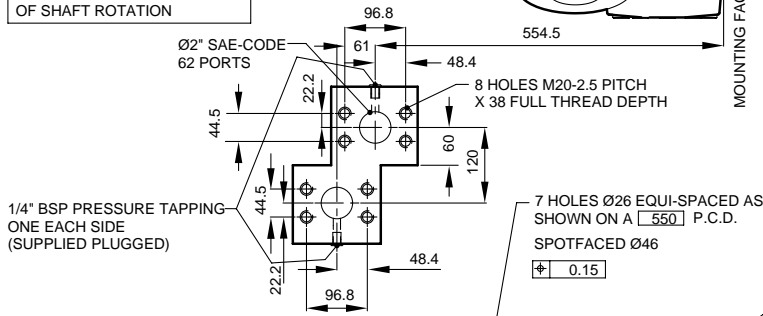

VIEW ON ARROW 'A'



Model Staffa

Page 69.70

Data Sheet M-1001/03.00



HMB700 Shaft Specification

SHAFT TYPE 'Z'
28 SPLINES TO DIN 5480.

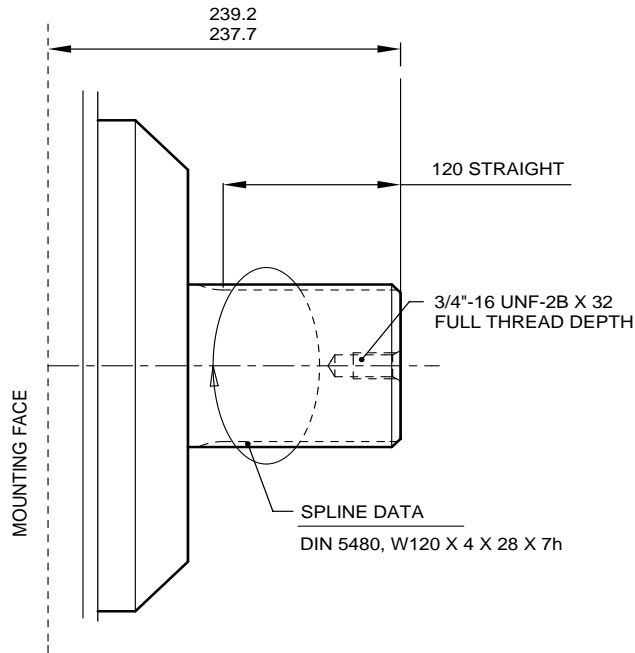

SHAFT TYPE 'P'
CYLINDRICAL SHAFT WITH 2 KEYS.

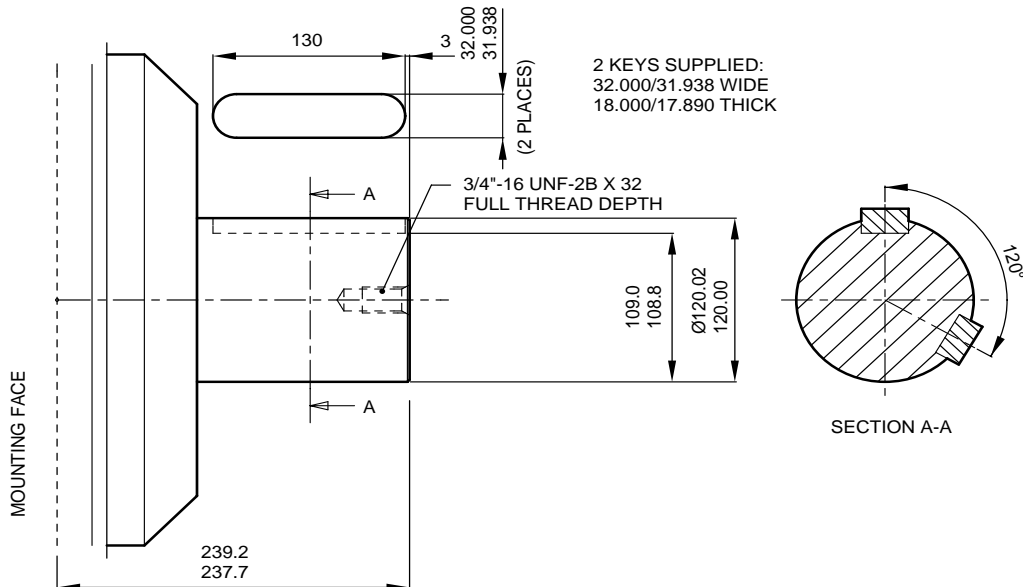

KAWASAKI PRECISION MACHINERY (UK) LTD
Ernesettle, Plymouth, Devon, PL5 2SA, England
Tel: +44 1752 364394 Fax: +44 1752 364816
E Mail: info@kpm-uk.co.uk
Web site: <http://www.kpm-uk.co.uk>

The specified data is for product description purposes only and may not be deemed to be guaranteed unless expressly confirmed in the contract

ALL RIGHTS RESERVED, SUBJECT TO REVISION

Model Staffa

Page 70.70

Data Sheet M-1001/03.00



Factory 19 / 5 Lyn Parade PRESTONS NSW 2170
Ph: (02) 9607 4100 Fax: (02) 9607 4200