

Axial Piston Motors for General Industrial Machinery

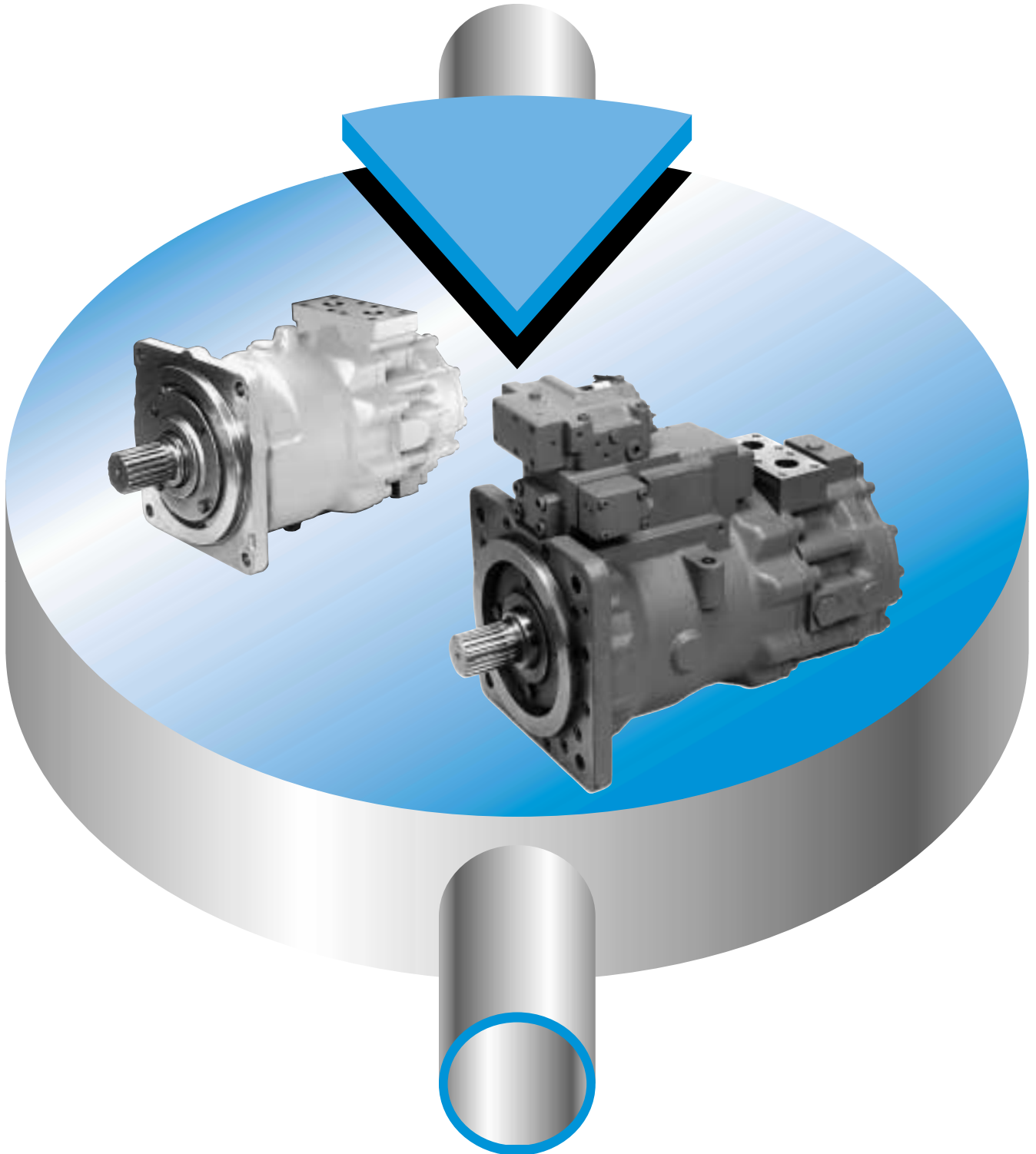

CONTENTS

You can go to a necessary page if you click a table of contents.

	page
ON APPLICATION / USE OF THE PRODUCTS	1
SAFETY PRECAUTIONS	2
WIDE VARIETY OF OUR SWASH-PLATE TYPE AXIAL PISTON MOTOR ..3	
Fixed-Displacement Type Axial Piston Motor	
M3X SERIES	5
Variable-Displacement Type Axial Piston Motor	
M3B SERIES	11
Axial Piston Motor with Reduction Gear	
M3X / M3B SERIES	23
Swash-Plate Type Axial Piston Motor	
K3X SERIES	25
OPERATION PRINCIPLE	27
PARKING BRAKE (Option)	27
DISPLACEMENT CHANGING MECHANISM OF M3B SERIES	28
CAUTION FOR HANDLING	29
PIPING	31
SPECIFICATION STUDIES	33



Factory 19 / 5 Lyn Parade PRESTONS NSW 2170
Ph: (02) 9607 4100 Fax: (02) 9607 4200

ON APPLICATION / USAGE OF THE PRODUCTS

Although our products are designed on the basis of our profound knowledge and long experience, and manufactured under the strict quality control system, the following must be taken into consideration in actual use.

1

The operating conditions of the products shown in this catalog vary depending upon each application. Therefore, the decision of the products' suitability to the system considered must be made by the designer of the hydraulic system and/or the person in charge of determining the specification after making analysis and conducting tests, if necessary. The study of the specification shall be done based on the latest catalog and technical documents, and the system must be composed taking into account situations regarding the possibility of machine failure.

2

Prior to use of the products, descriptions given in the SAFETY PRECAUTIONS must be observed for the proper use.

3

The technical information in this catalog represents typical characteristics and performance of the products, and is not guaranteed one.

4

In case the products are used in the following conditions or environments, please consult us prior to the use.

- ① Unspecified conditions or environments
- ② Use for atomic power, aviation, medical treatment, and/or food
- ③ Use likely to affect human beings or assets significantly or requiring particular safety

5





The information described in this catalog is subject to change without notice. For updated information, please consult us.

SAFETY PRECAUTIONS





Before you use the product, you **MUST** read the operation or operators manual and **MUST** fully understand how to use the product.

To use the product safely, you **MUST** carefully read all Warnings and Cautions in this manual. You **MUST** also observe the related regulations and rules regarding safety.







■ Cautions related to operation

- ①  **CAUTION** Use the safety equipment to avoid the injury when you operate the product.
- ②  **CAUTION** Pay enough attention on handling method to avoid pinching hands or back problems that may be caused by heavy weight of the product or handling posture.
- ③  **CAUTION** Do not step on the product, hit it, drop it or give strong outside force to it, as one of these actions may cause the failure of work, damage or oil leakage.
- ④  **CAUTION** Wipe the oil on the product or floor off completely, as the oil creates slippery conditions that may result in dropping the product or injuring.





■ Warnings and Cautions related to installation and removal of the product

- ①  **CAUTION** Installation, removal, plumbing, and wiring must be done by the certified person.
*CERTIFIED PERSON : a person who has enough knowledge like a person who is trained by Kawasaki's hydraulic school.
- ②  **WARNING** Make it sure that the power of the hydraulic power unit is turned off and that the electric motor or engine has completely stopped before starting installation or removal. You must also check the system pressure has dropped to zero.
- ③  **WARNING** Turn off the power before starting wiring or other works related to the electric power, otherwise you may be stuck by an electric shock.
- ④  **CAUTION** Clean the threads and mounting surface completely, otherwise you may experience damages or oil leakage caused by insufficient tightening torque or broken seal.
- ⑤  **CAUTION** Use the specified bolts and keep the specified tightening torque when you install the product. Usage of unauthorized bolts, lack of torque or excess of torque may create problems such as failure of work, damage and oil leakage.

■ Warnings and Cautions for operation

- ①  **DANGER** Never use the product not equipped with anti-explosion protection in the circumstances of possible explosion or combustion.
- ②  **WARNING** Shield the rotating part such as motor shaft and pump shaft to avoid injuries caused by being caught of fingers or cloths.
- ③  **WARNING** Stop the operation immediately if you find something wrong such as unusual noise, oil leakage or smoke, and fix it properly. If you continue operating, you may encounter damage, fire or injury.
- ④  **CAUTION** Make it sure that plumbing and wiring are correct and all the connection is tightened correctly before you start operating, especially if it is the first run.
- ⑤  **CAUTION** Use the product under the specification mentioned in the catalog, drawings and specification sheet.
- ⑥  **CAUTION** Keep your body off the product during the operations as it may become hot and burn your body.
- ⑦  **CAUTION** Use the proper hydraulic oil, and maintain the contamination in the recommended level, otherwise it may not work or be damaged.

■ Cautions related to maintenance

- ①  **CAUTION** Never modify the product without approval of Kawasaki.
- ②  **CAUTION** Do not disassemble and assemble without approval by Kawasaki. It may cause troubles and failure, or it may not work as specified. If it is necessary by all means to disassemble and assemble, it must be done by an authorized person.
- ③  **CAUTION** Keep the product from dust and rust by paying attention to the surrounding temperature and humidity when you transport or store the product.
- ④  **CAUTION** Replacing the seals may be required if you use the product after long time storage.

High-Performance Motors You Have Been Waiting for

Kawasaki Swash-Plate Type Axial Piston Motors

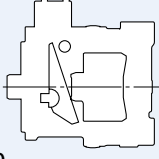
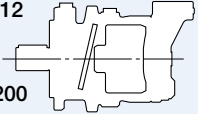
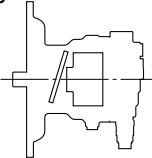
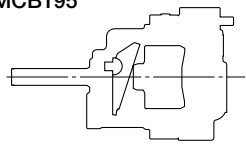
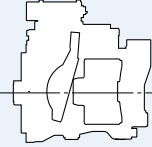
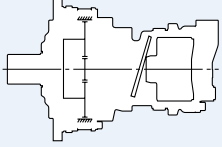
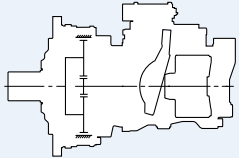
Displacement (cm ³)	for General Use		for Industrial Vehicles	
	General	General	for Swing	for Travel
	Fixed	Variable	Fixed	Variable
	P rated=31.4MPa (K3X series) 29.4MPa 20.6MPa (Reduction gear type)	P rated=29.4MPa 20.6MPa (Reduction gear type)	P rated=20.6MPa (size 22,45) 29.4MPa (size 63,210) 32.4MPa (size 130,180)	P rated=34.3MPa
	P max. = 34.3MPa	P max. = 34.3MPa	P max. =24.5MPa (size 22,45) 34.3MPa (size 63,210) 39.2MPa (size 130,180)	P max. = 41.2MPa
50	K3X63		M2X63	
80	K3X80		M5X130	
100	K3X90		M5X180	
150	K3X112		M2X210	
200		M3B200		MCB195
250	M3X280	M3B280		
500	M3X530	M3B530		MCB530
750	M3X800	M3B800		
1,000	M3X200-RG03S with Reduction Gear		M2X63-RG06 with Reduction Gear P rated=28.0MPa	
1,500	M3X280-RG06S with Reduction Gear	M3B280-RG06S with Reduction Gear	M5X130-RG10 with Reduction Gear P rated=27.4MPa	
3,000			M5X180-RG16 with Reduction Gear P rated=24.0MPa	
	M3X530-RG10S with Reduction Gear	M3B530-RG10S with Reduction Gear	M5X180-RG20 with Reduction Gear P rated=29.4MPa	DNB25 with Reduction Gear T max. = 26.3kN·m
5,000	M3X800-RG16S with Reduction Gear	M3B800-RG16S with Reduction Gear	M5X180-RG17C with Reduction Gear P rated=23.0MPa	
			M5X180-RG23C with Reduction Gear P rated=24.5MPa	DNB50 with Reduction Gear T max. = 58.8kN·m
20,000			M3X280-RG100C with Reduction Gear P rated=27.5MPa	DNB60 with Reduction Gear T max. = 63.7kN·m

This catalog introduces motors for general use. (Colored in in the above table.)

FEATURES

1. Wide variety variation

- Fixed Displacement Motors

M3X series consists of 4 models and 10 displacement types ranging from 149cm³ to 800cm³. M3X with reduction gear series covers a displacement range from 845cm³ to 5,120cm³. K3X series is made up of 4 models with displacement range from 63cm³ to 111cm³.

- Variable Displacement Motors

M3B series consists of 4 models with displacement range from 195cm³ to 800cm³ and from 1,512cm³ to 5,120cm³ for those with reduction gears. Several combinations of large and small displacements are available along with a wide variation of regulators are also available for various control options.

2. Excellent self-priming capability and max. speed (M3X, M3B, K3X)

- A spherical surface type valve plate and full-balancing mechanism enhance self-priming capability and max. speed.

3. High reliability based on long experience (M3X, M3B)

- Building on the knowledge and experiences of reputed MX/MB series, M3X/M3B series have been widely used especially as winch motors.

4. Optional parts (M3X, M3B)

- Built-in parking brake is available for M3X/M3B motors.
- Various control valves are available for M3X/M3B motors.

5. Other motors

- M2X/M5X series motors are specifically designed for swing function of construction machinery.
- MCB series plug-in motors and DNB series case rotating type geared motors are available for traveling construction machinery.
- Low speed, high torque radial piston motors are prepared for general industrial use.

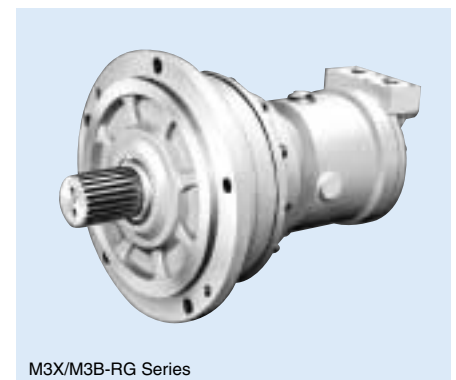
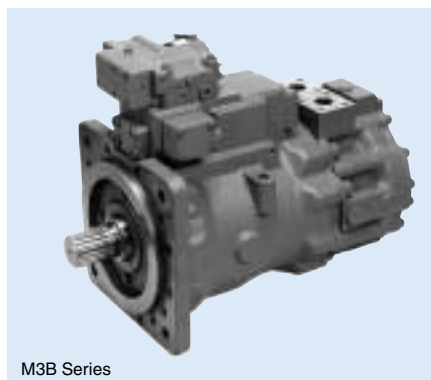
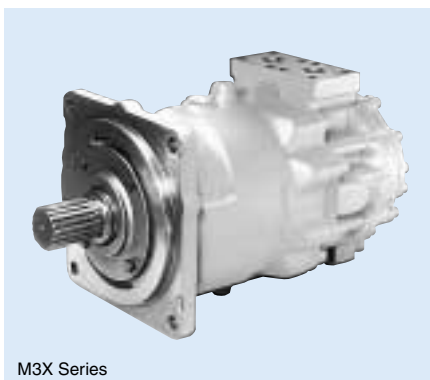



M3X Series

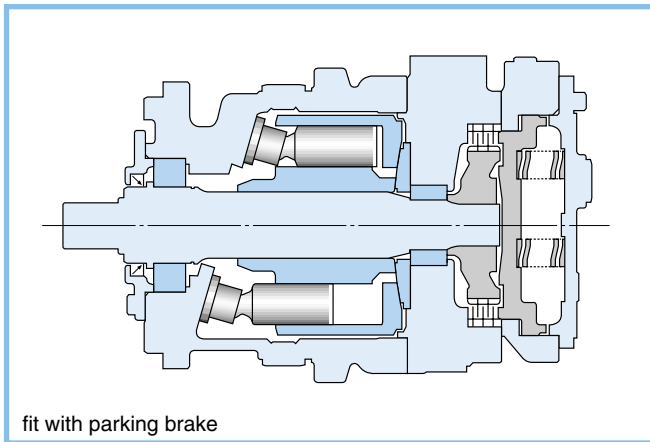

The M3X series are newly developed motors for construction machinery, industrial machinery or other applications.

The design based on technology and experience of current MX series is more compact and enables a speed range.

● FEATURES

1. Advanced Low Speed Characteristics

New design which reduces pressure ripple and friction enabling expanded lower speed limit and smooth starting characteristics.

2. High Speed Operation

New materials enable an increase in the maximum speed which has 1.5 times of current MX series.

3. Best Fit

4 models and 10 capacity motors are carried in 149-800 cm³. Installation is the same as current MX series. Larger capacity is possible with reduction gears RG series. (Refer to page 23)

● ORDERING CODE

M3X 530 - A C N - 485 - 001A - D3

M3X series

size

200 : 195cm³ 530 : 533cm³
280 : 280cm³ 800 : 800cm³

optional function code

A : standard
B : fit with a parking brake

shaft code

C : JIS involute spline (external) (standard)
P : JIS involute spline (internal)
1 : JIS straight key

direction of rotation (A port: high press., view from shaft end)

N : clockwise rotation (standard)
M : anti-clockwise rotation

oil temp. code

marks	oil temperature range	remarks
V2	90°C < θ °C	all seal parts: fluoro-rubber
V1	90°C ≥ θ °C	oil seal: fluoro-rubber
blank	-20°C ≤ θ ≤ 90°C	
D1	-30°C < θ < -20°C	
D3	-45°C ≤ θ ≤ -30°C	

design code

optional capacity
showed only optional capacity

SPECIFICATIONS

model		M3X200	M3X280	M3X530	M3X800	
displacement		Vg cm ³	195	280	533	800
pressure MPa (kgf/cm ²)	rated	29.4 (300)				
	max.	34.3 (350)				
max. speed		n max min ⁻¹	1,900	1,700	1,400	1,200
max. flow		L/min	370	480	750	960
rated torque		N·m	910	1,310	2,500	3,750
rated power		kW	180	230	370	470
case volume		L	1.0	1.3	2.5	3.8
moment of inertia		N·m ²	1.4	3.0	7.3	14
mass	kg	standard	42	62	90	133
		with parking brake	—	80	134	195

M3X Optional capacities

model	capacity (☆ : standard) max. speed			
	Vg	☆	☆	☆
M3X200	Vg	☆ 195	149	cm ³
	n max.	1,900	2,140	min ⁻¹
M3X280	Vg	☆ 280	252	
	n max.	1,700	1,770	
M3X530	Vg	☆ 533	499	(485)
	n max.	1,400	1,400	1,420
M3X800	Vg	☆ 800	751	(737)
	n max.	1,200	1,230	1,240

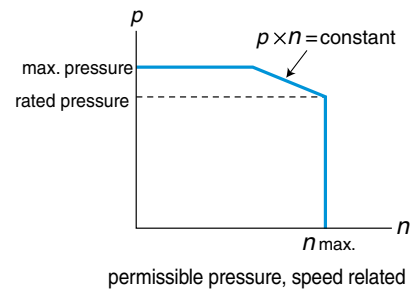

CALCULATION FORMULA

■ required input flow L/min

$$qv = \frac{Vg \cdot n}{1,000 \cdot \eta v}$$

■ output speed min⁻¹

$$n = \frac{qv \cdot 1,000 \cdot \eta v}{Vg}$$

■ output torque N·m (kgf·m)

$$T = \frac{Vg \cdot \Delta p \cdot \eta hm}{2 \cdot \pi}$$

■ output power kW (PS)

$$P = \frac{2\pi \cdot T \cdot n}{60,000} = \frac{T \cdot n}{9,550}$$

$$= \frac{qv \cdot \Delta p}{60} \cdot \eta t$$

Vg	displacement	cm ³
T	torque	N·m
n	speed	min ⁻¹
Δp	effective pressure difference	MPa (kgf/cm ²)
ηv	volumetric efficiency	
ηhm	mechanical efficiency	
ηt	overall efficiency	

DIMENSIONS

[M3X***ACN]

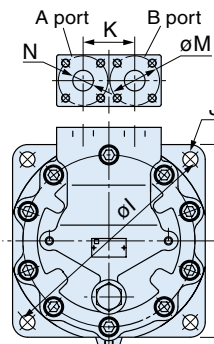
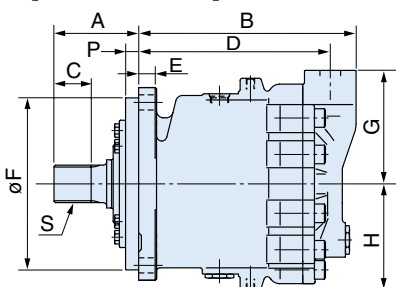

[M3X***BPN]

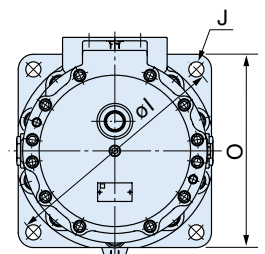
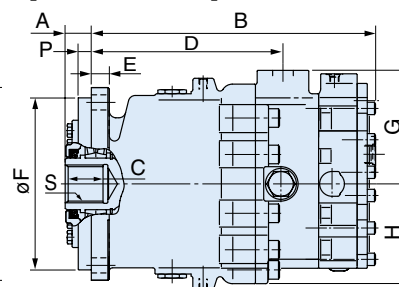

(mm)

size	A	B	C	D	E	F	G	H	I	J	K	L	M	N	O	P	S
M3X200ACN	107	263	50	225	20	160	115	110	224	4-ø18	75	2 x 4, M12-17.5	72	22	190	9	m=2.5, z=16
M3X200APN	49	263	35	225	20	160	115	110	224	4-ø18	75	2 x 4, M12-17.5	72	22	190	9	m=2.5, z=13
M3X280ACN	98	290	45	252	22	200	130	124	268	4-ø17	75	2 x 4, M12-17.5	72	25	230	11	m=2.5, z=16
M3X280BPN	33	290	44	252	22	200	130	124	268	4-ø17	75	2 x 4, M12-17.5	72	25	230	11	m=2.5, z=16
M3X530ACN	123	316	54	278.5	24	250	165	154	335	4-ø22	75	2 x 4, M12-17.5	72	30	280	19	m=2.5, z=20
M3X530BPN	38	413	55	278.5	24	250	165	154	335	4-ø22	75	2 x 4, M12-17.5	72	30	280	19	m=2.5, z=20
M3X800ACN	130	350	62	312.5	27	280	178	169	376	4-ø22	75	2 x 4, M12-17.5	72	28	310	16	m=3, z=19
M3X800BPN	45	461	62	325	27	280	178	169	376	4-ø22	102	2 x 4, M16-23	92	30	310	16	m=3, z=19

PERFORMANCE CURVE

The values given in the below figures are mean ones, and not guaranteed ones.

M3X200

Mechanical efficiency (%)

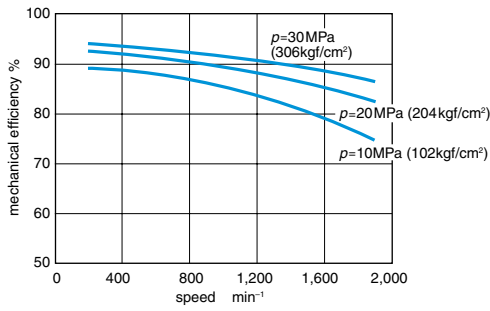

Starting mechanical efficiency

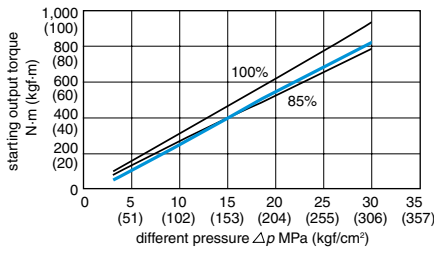

Idle & boost-graph

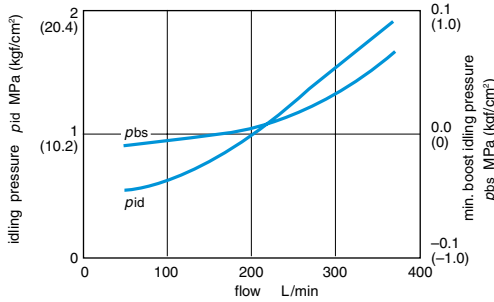

Volumetric efficiency

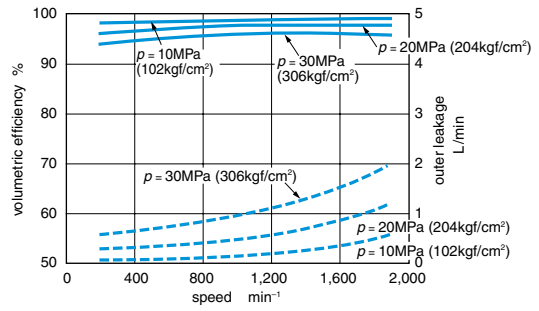

Radial load and bearing life

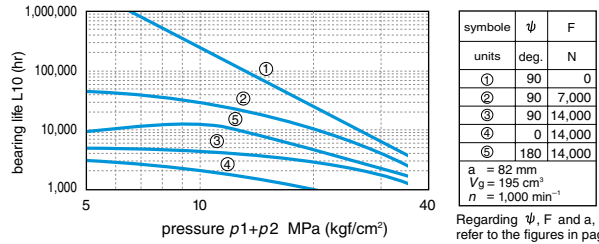

Regarding ψ, F and a, please refer to the figures in page 9.

Shaft creep speed

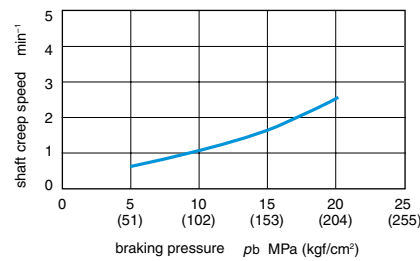

M3X280

Mechanical efficiency (%)

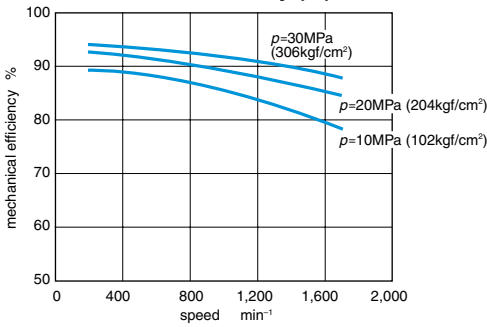

Starting mechanical efficiency

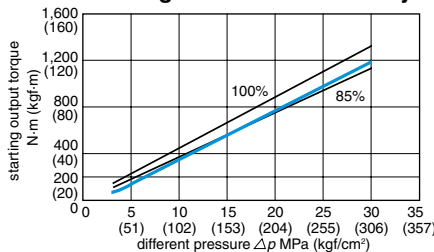

Idle & boost-graph

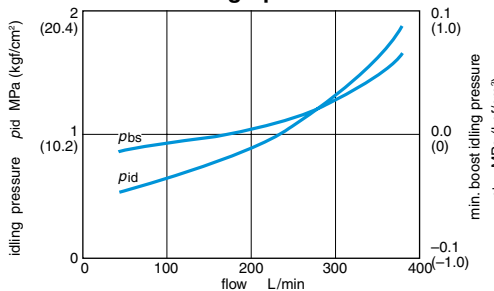

Volumetric efficiency

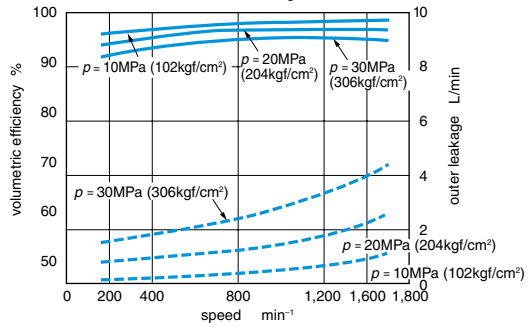

Radial load and bearing life

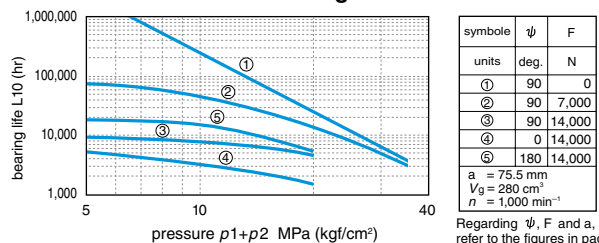

Regarding ψ, F and a, please refer to the figures in page 9.

Shaft creep speed

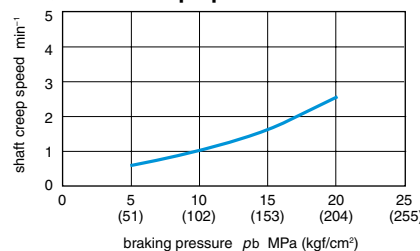

oil temperature : 50°C
oil viscosity : 32mm²/s

M3X530

Mechanical efficiency (%)

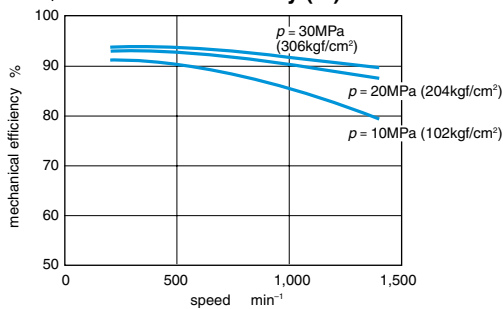

Starting mechanical efficiency

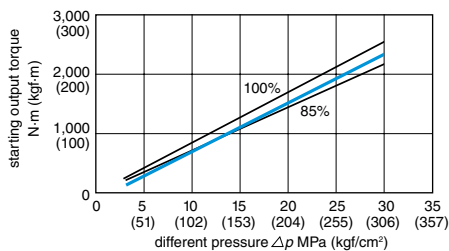

Idle & boost-graph

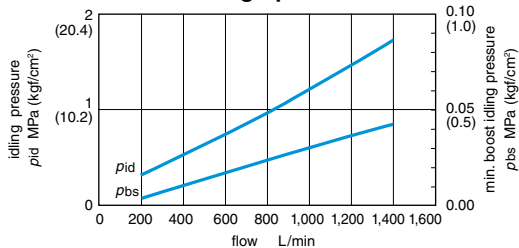

Volumetric efficiency

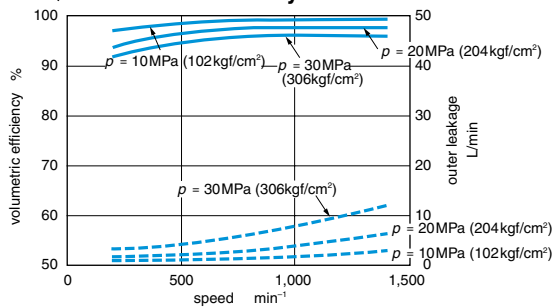

Radial load and bearing life

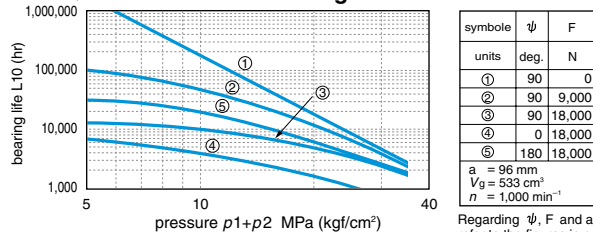

symbole	ψ	F
units	deg.	N
①	90	0
②	90	9,000
③	90	18,000
④	0	18,000
⑤	180	18,000

a = 96 mm
V_g = 533 cm³
n = 1,000 min⁻¹

Regarding ψ , F and a, please refer to the figures in page 9.

Shaft creep speed

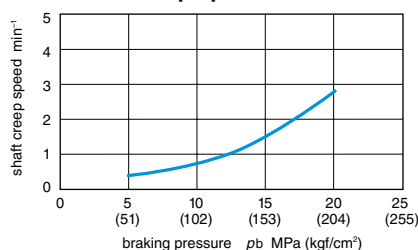

M3X800

Mechanical efficiency (%)

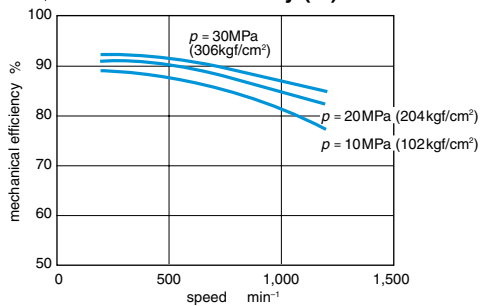

Starting mechanical efficiency

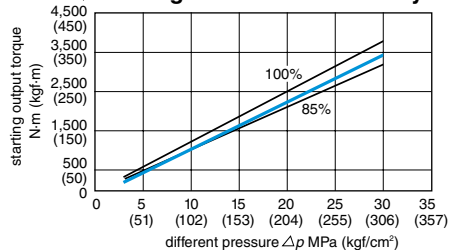

Idle & boost-graph

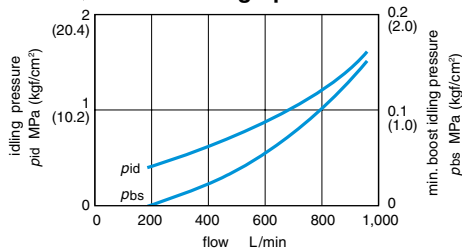

Volumetric efficiency

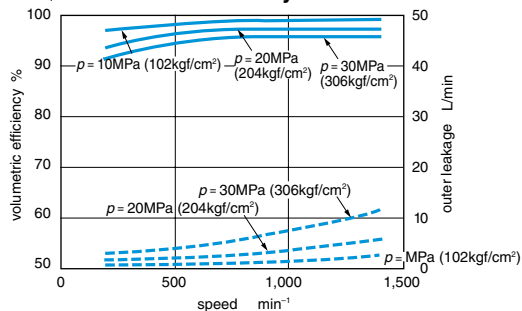

Radial load and bearing life

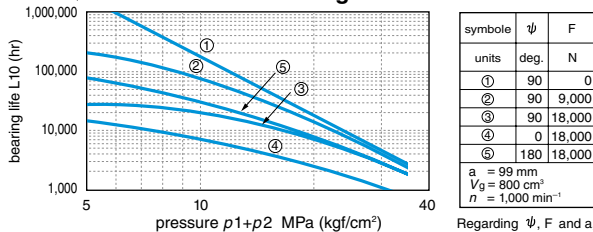

symbole	ψ	F
units	deg.	N
①	90	0
②	90	9,000
③	90	18,000
④	0	18,000
⑤	180	18,000

a = 99 mm
V_g = 800 cm³
n = 1,000 min⁻¹

Regarding ψ , F and a, please refer to the figures in page 9.

Shaft creep speed

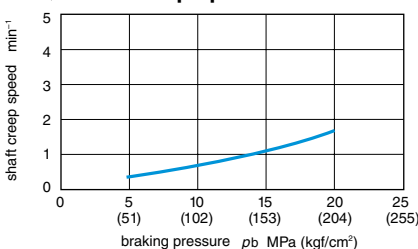

● BEARING LIFE

- The calculated life (B₁₀ life) shown in the graph is for speed
 $N_0 = 1,000 \text{ min}^{-1}$
 Calculation of life for a random speed N is as follows.

$$L = \frac{N_0}{N} \times L_0 \quad (L_0 : \text{calculated life for } N_0)$$

◆ M3X Front bearing life

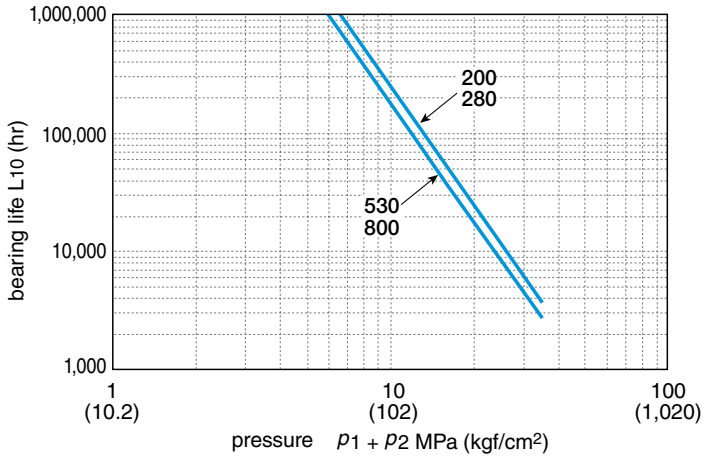

◆ M3X Rear bearing life

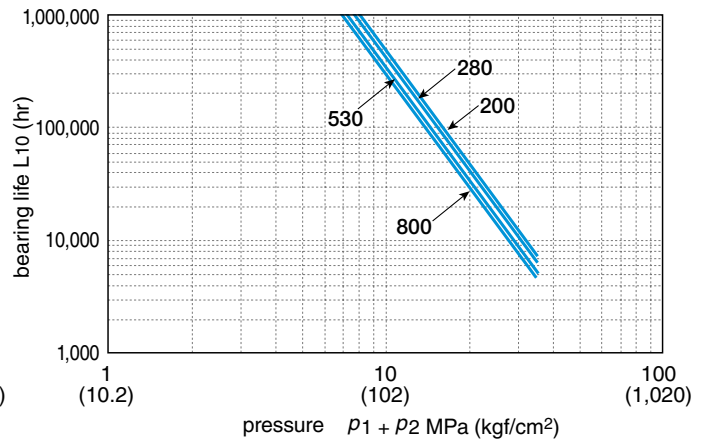

(Note) p_1 : inlet pressure p_2 : outlet pressure

● RADIAL LOAD

- In case that radial load is applied, you are requested to install the motor so as to place the radial load toward the arrow direction shown in below. Please refer to the relevant list of each motor for allowable radial load.

[M3X200]

[M3X530]

[M3X800]

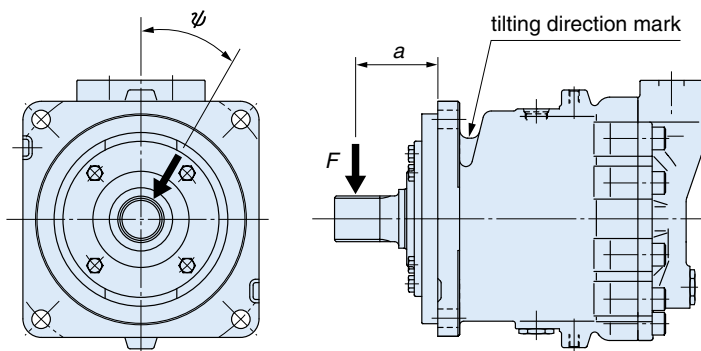

[M3X280]

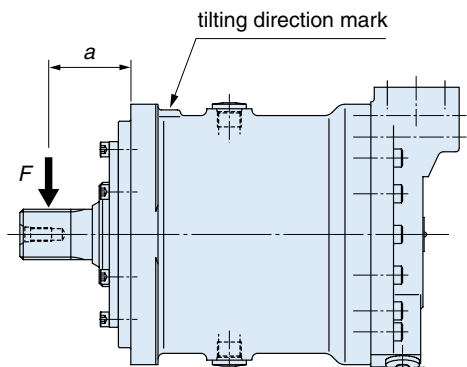

● PARKING BRAKE

model		M3B200			M3X280/M3B280			M3X530/M3B530			M3X800/M3B800			
brake torque		N·m	1,400	1,050	530	1,750	1,320	660	3,770	2,820	1,410	5,010	3,770	1,880
brake release pressure MPa (kgf/cm ²)	cracking		1.8(18)	1.4(14)	0.7(7)	2.3(23)	1.8(18)	0.9(9)	2.4(25)	1.8(18)	0.8(8)	2.4(25)	1.8(18)	0.8(8)
	stroke end		2.3(23)	1.8(18)	0.9(9)	3.0(31)	2.3(23)	1.2(12)	3.1(32)	2.3(23)	1.2(12)	3.1(32)	2.3(23)	1.2(12)
brake order code	pilot release	low press.	L16-G (standard)	L12-G	L6-G	L16-G (standard)	L12-G	L6-G	L16-G (standard)	L12-G	L6-G	L16-G (standard)	L12-G	L6-G
		high press.	—	—	—	—	—	—	H16-G	H12-G	L6-G	H16-G	H12-G	H6-G
	valve release	high press.	—	—	—	—	—	—	—	—	H6-B	—	—	H6-B

(Note1) The mechanical brakes of M3X/M3B series shall be used for parking only so please make sure not to apply the brakes when motors are driving.

(Note2) In case of low pressure release type, brake release shall be conducted by providing hydraulic oil pressured more than stroke end pressure and less than 7.8 MPa (80kgf/cm²)

Please note that effective pressure is the differential pressure between brake release and drain.

(Note3) In case of motors with H6-B as brake model code, release pressure is provided from traveling counterbalance valve, and the brake is automatically released.

◆ Hydraulic symbols

brake order code : L ※ ※ - G

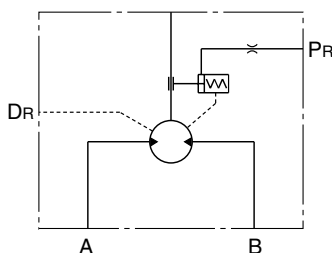

brake order code : H ※ ※ - G

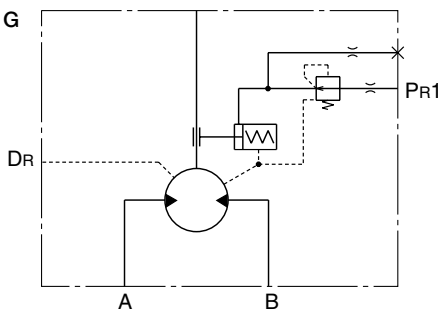

brake order code : H 6 - B

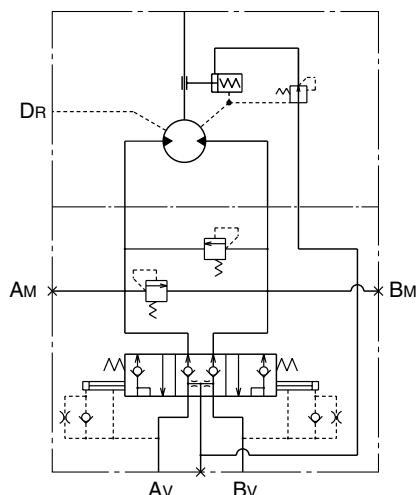

◆ Outline view of brake port

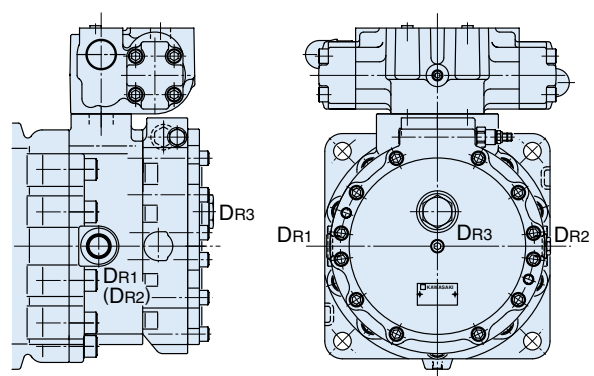
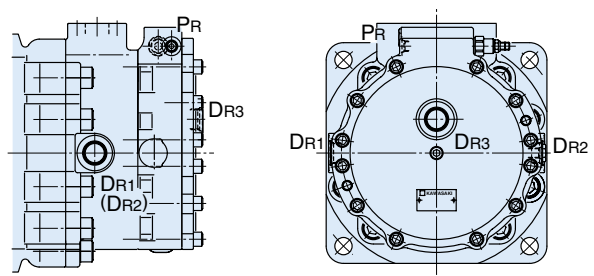
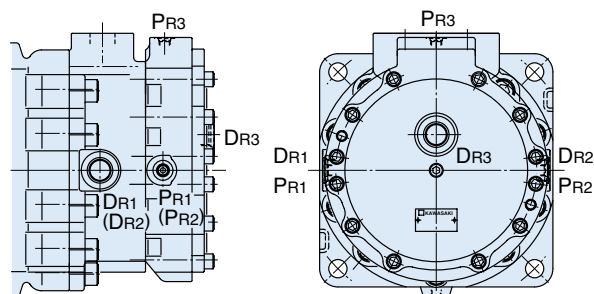



M3B Series

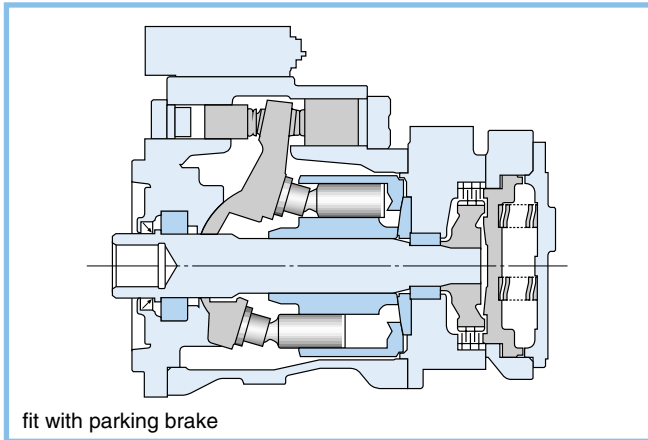

The M3B Series are variable displacement type motors with the same rotary components of M3X Series which enable the advanced low speed characteristic and high speed operation.

The design of various displacement control is based on current MB Series. The range of displacement is 100%–33% with 3 types of various displacement control regulators. Electric displacement control is also possible.

● FEATURES

1. Advanced Low-Speed Characteristics

New design which reduces pressure ripple and friction enabling expanded lower speed limit and smooth starting characteristics.

2. High-Speed Operation

New materials and enlargement of variable displacement range have enabled the higher maximum speed. The ratio of large to small displacement is enlarged from 2 (old model/MB series) to 3.

3. Various Displacement Control Regulator (3 Type)

- A: Directional control valve
- B: Sequence control regulator
- C: Speed & CHP control regulator (Refer to next page)

4. Electric Displacement Control

The pilot pressure can be controlled by a solenoid-operated directional control valve or a pressure-reducing valve.

● ORDERING CODE

M3B 530 - A C - 533 / 178 - 001A - D3

M3B series _____

size _____

200 : 195cm³ ~ 106cm³
 280 : 280cm³ ~ 93cm³
 530 : 533cm³ ~ 178cm³
 800 : 800cm³ ~ 267cm³

optional function code _____

A : standard
 B : fit with a parking brake

shaft code _____

C : JIS involute spline (external)
 P : JIS involute spline (internal) (standard)
 1 : JIS straight key

oil temp. code _____

marks	oil temperature range	remarks
V2	90°C < θ °C	all seal parts: fluoro-rubber
V1	90°C \geq θ °C	oil seal: fluoro-rubber
blank	-20°C \leq θ \leq 90°C	
D1	-30°C < θ < -20°C	
D3	-45°C \leq θ \leq -30°C	

design code _____

small displacement (cm³) _____

large displacement (cm³) _____

SPECIFICATIONS

model		M3B200	M3B280	M3B530	M3B800
displacement cm ³	max. Vg, max.	195	280	533	800
	min. Vg, min.	106	93	178	267
pressure MPa (kgf/cm ²)	rated	32.0	30.0	29.4 (300)	
	max.	35.0	35.0	34.3 (350)	
max. speed min ⁻¹	n1, max. at Vg, max.	1,900	1,700	1,400	1,200
	n2, max. at ≤ 1/2 Vg, max.	2,930	2,200	1,700	1,500
max. flow	L/min	370	480	750	960
rated torque	N-m	990	1,340	2,500	3,750
rated power	kW	200	240	370	470
case volume	L	1.6	2.2	4.2	6.3
moment of inertia	N-m ²	1.4	3.0	7.3	14
mass kg	standard	72	93	147	235
	with parking brake	88	110	189	277

◆ Regulator

A : Directional control valve
Shifts displacement small or large by remote control signal.

B : Sequence control regulator
Automatically shifts displacement small or large depending on the load.

C : Speed & CHP control regulator
Maintains constant horsepower regardless of the load. Controls displacement at any position by pilot pressure. The pilot pressure can be controlled by a solenoid-operated directional control valve or a pressure-reducing valve.

CHP : Constant horsepower

◆ M3B Optional capacities

model	capacity (☆: standard)		max. speed													
	Vg,1	☆ nx,max.	cm ³	min ⁻¹												
M3B200	Vg,1	☆ 195	195	1,900												
	☆ nx,max.	116	106	2,790												
	Vg,2	127	2,930													
M3B280	Vg,1	☆ 280	252	1,700	200	166	149	☆ 140	132	115	99	93				
	☆ nx,max.	1,770	2,060	2,110												
	Vg,2	200	2,200													
M3B530	Vg,1	☆ 533	485	1,400	370	340	327	315	280	☆ 267	242	214	192	178		
	☆ nx,max.	1,430	1,660													
	Vg,2	1,700														
M3B800	Vg,1	☆ 800	751	1,200	554	533	500	470	434	420	☆ 400	369	321	267		
	☆ nx,max.	1,300	1,490													
	Vg,2	1,500														

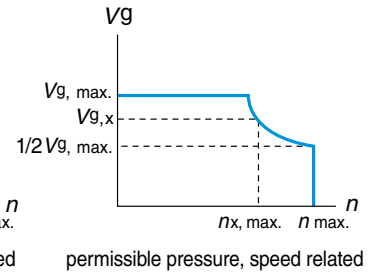
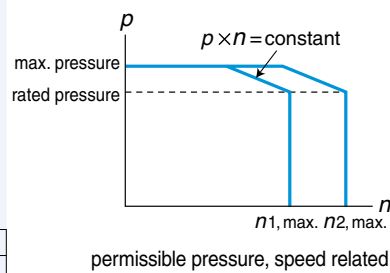

DIMENSIONS

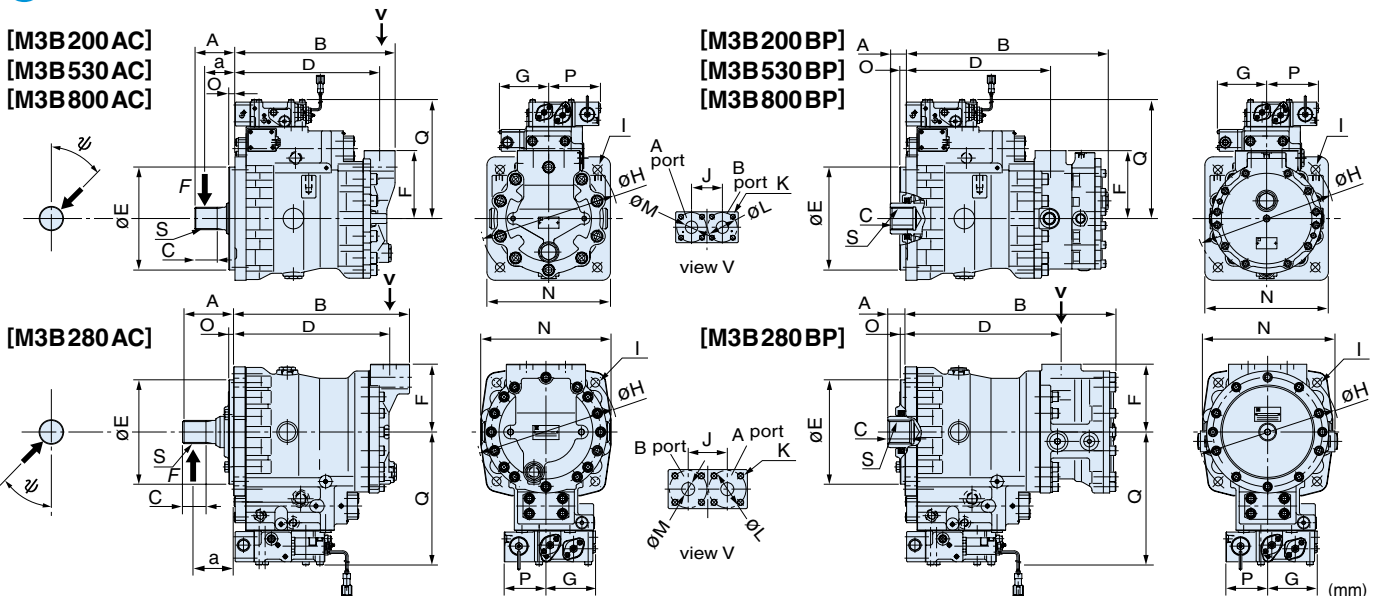

size	A	B	C	D	E	F	G	H	I	J	K	L	M	N	O	P	Q	S
M3B200AP	40	286	56	249	200	144	70	250	4-ø22	75	2 x 4, M10-17.5	62	22	236	9	110	198	m=2.5, z=16
M3B200BP	40	368	56	249	200	144	70	250	4-ø22	75	2 x 4, M10-17.5	62	22	236	9	110	198	DP=12/24, z=17
M3B280AC	98	338	45	299.5	200	130	95	268	4-ø17	75	2 x 4, M12-17.5	72	25	250	9	80	255	m=2.5, z=16
M3B280BP	33	405	51	299.5	200	130	95	268	4-ø17	75	2 x 4, M12-17.5	72	25	250	9	80	255	m=2.5, z=16
M3B530AC	97	389	54	351.5	250	165	119	335	4-ø22	75	2 x 4, M12-17.5	72	30	300	15	126	289	m=2.5, z=20
M3B530BP	38	486.5	55	351.5	250	165	119	335	4-ø22	75	2 x 4, M12-17.5	72	30	300	15	126	289	m=2.5, z=20
M3B800AC	124	429	64	391.5	280	178	130	376	4-ø22	75	2 x 4, M12-17.5	72	28	345	16	133.5	330	m=3, z=19
M3B800BP	20	540	64	404	280	178	130	376	4-ø22	102	2 x 4, M16-23	92	30	345	16	133.5	330	m=3, z=19

PERFORMANCE CURVE

The values given in the below figures are mean ones, and not guaranteed ones.

M3B200

Mechanical efficiency (%)

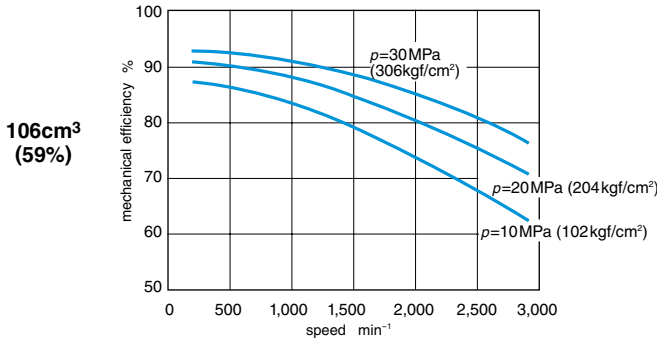
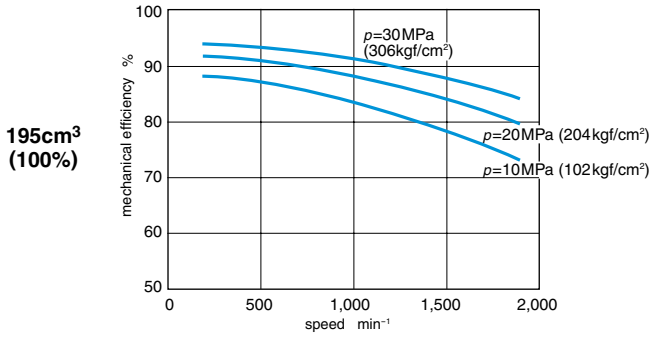

Starting mechanical efficiency

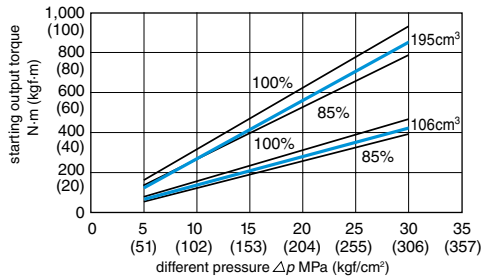

Idle & boost-graph

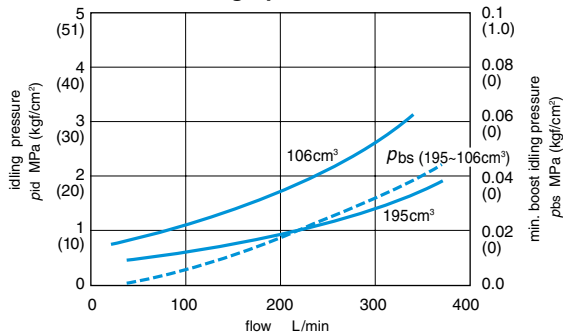

Volumetric efficiency

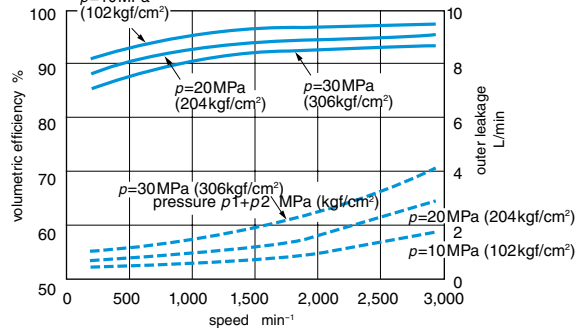
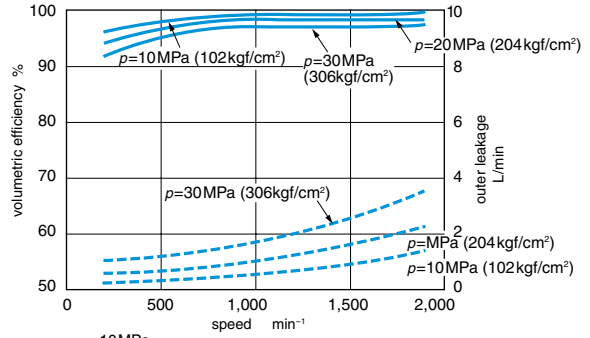

Radial load

No radial load shall be applied to M3B200.

Shaft creep speed

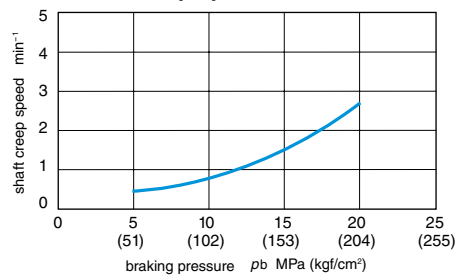

Bearing life

The calculated life (B_{10} life) shown in the graph is for speed $N_0 = 1,000 \text{ min}^{-1}$. Calculation of life for a random speed N and a random displacement is as follows.

$$L_x = \frac{V_{g.1}}{V_{g.x}} \cdot \frac{N_0}{N_2} \times L_0$$

L_0 : refer to this graph
 $V_{g.1}$: max. displacement

(Note)
 p_1 : inlet pressure
 p_2 : outlet pressure

Front bearing life

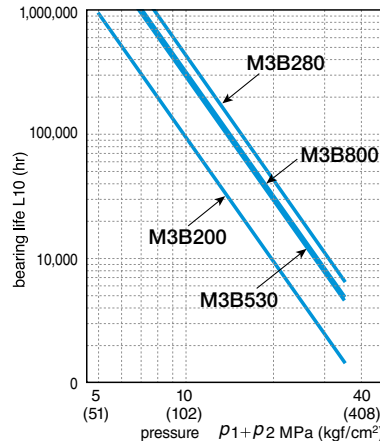

Rear bearing life

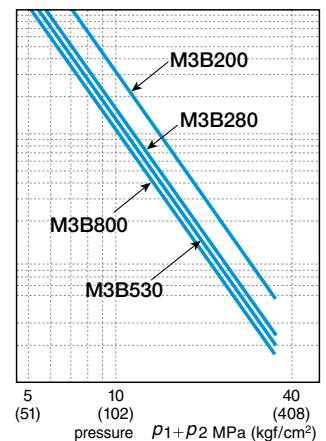

oil temperature: 50°C
oil viscosity: 32mm²/s

M3B280

280cm³
(100%)

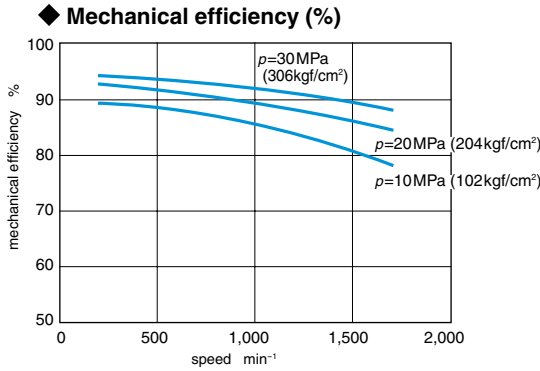

140cm³
(50%)

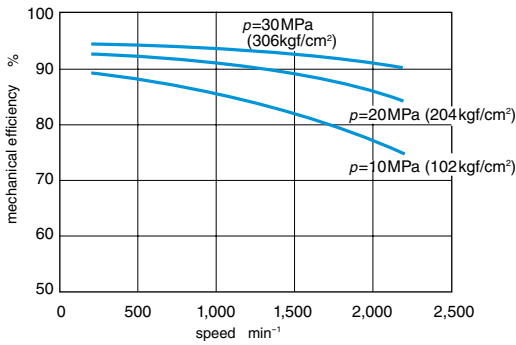

93cm³
(33%)

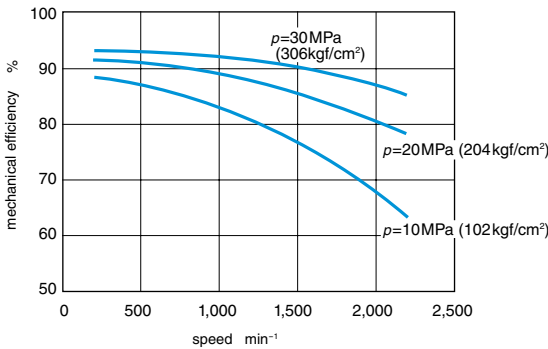

Volumetric efficiency

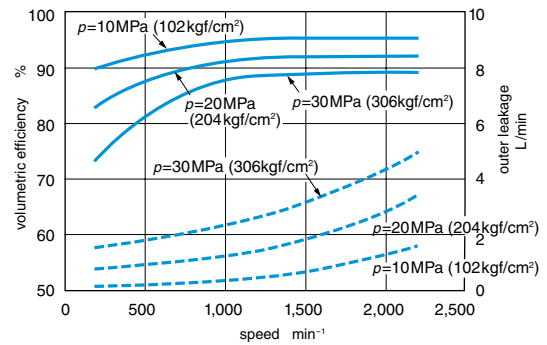
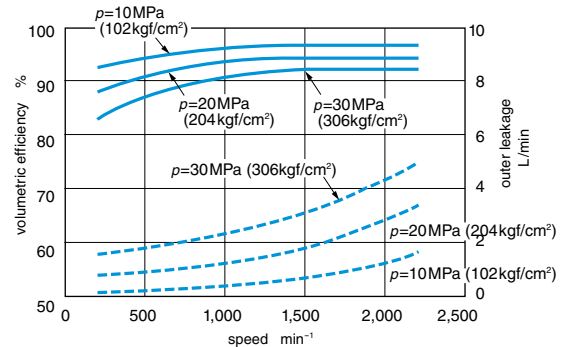
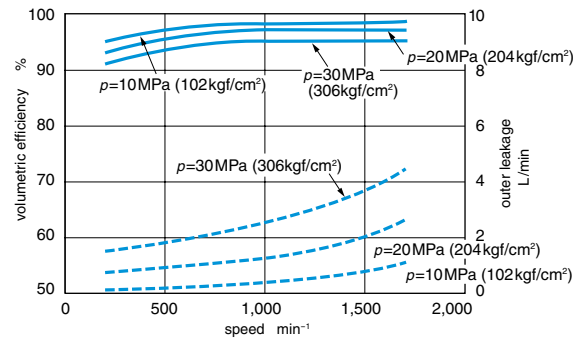

Starting mechanical efficiency

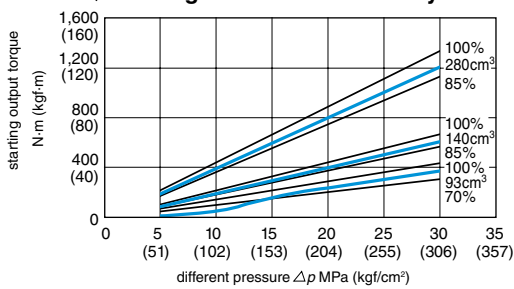

Radial load and bearing life

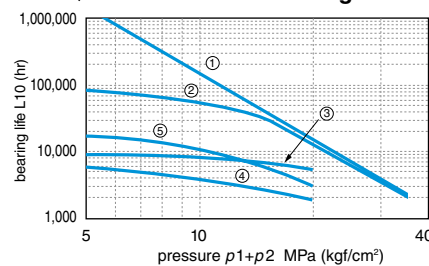

symbols	ψ	F
units	deg.	N
①	90	0
②	90	7,000
③	90	14,000
④	0	14,000
⑤	180	14,000

Regarding ψ , F and a, please refer to the figures of DIMENSIONS in page 12.

Idle & boost-graph

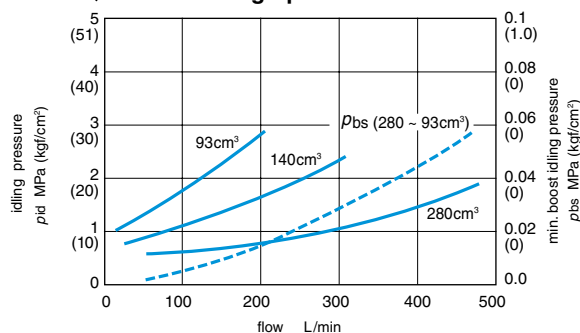

Shaft creep speed

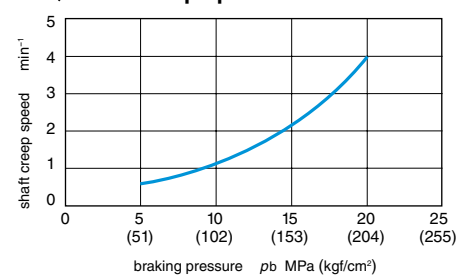

PERFORMANCE CURVE

The values given in the below figures are mean ones, and not guaranteed ones.

M3B530

Mechanical efficiency (%)

533cm³
(100%)

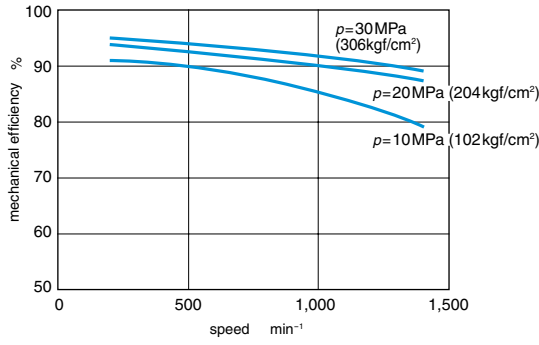

267cm³
(50%)

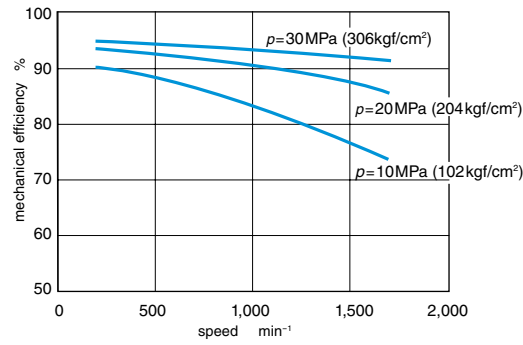

178cm³
(33%)

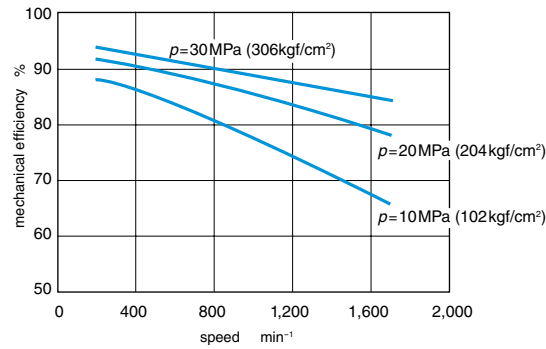

Starting mechanical efficiency

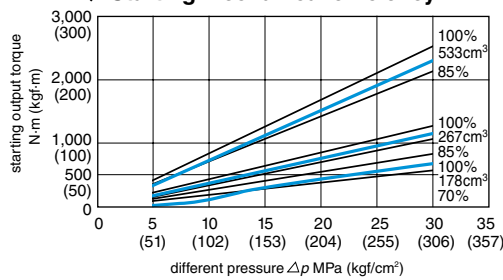

Idle & boost-graph

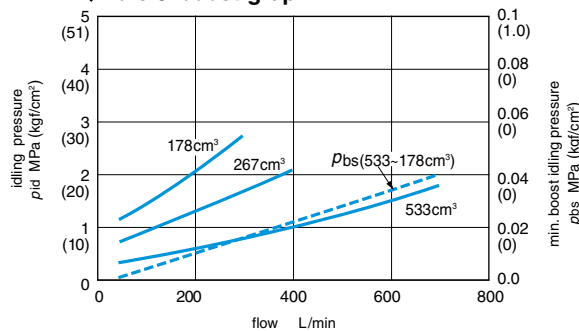

Volumetric efficiency

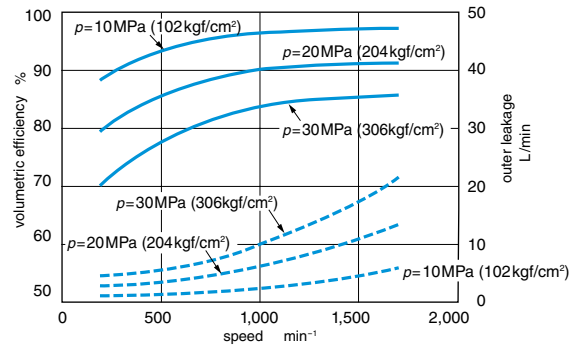
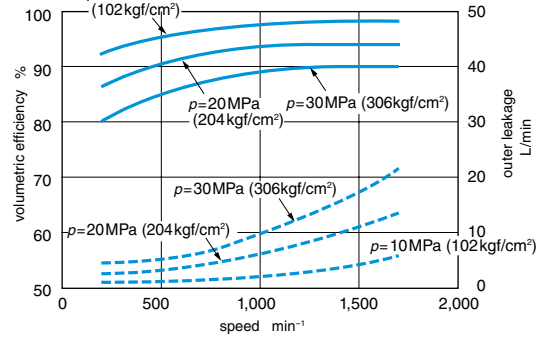
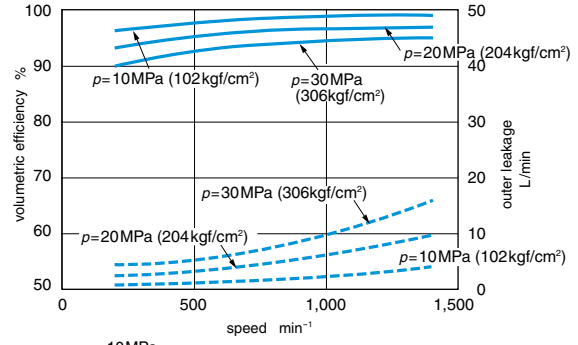

Radial load and bearing life

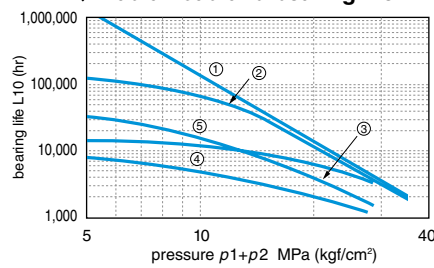

simbole	ψ	F
units	deg.	N
①	90	0
②	90	9,000
③	90	18,000
④	0	18,000
⑤	180	18,000

Regarding ψ, F and a, please refer to the figures of DIMENSIONS in page 12.

Shaft creep speed

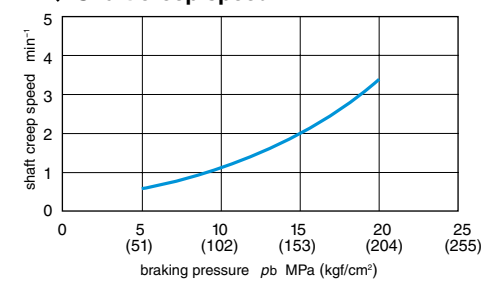

oil temperature: 50 °C
oil viscosity: 32 mm²/s

M3B800

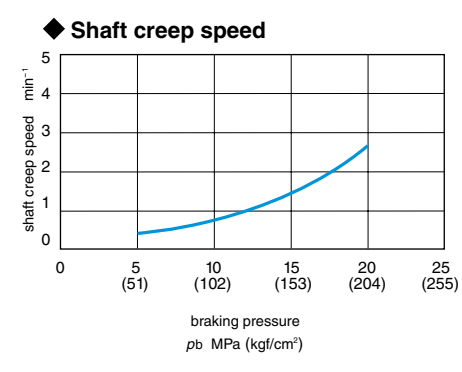
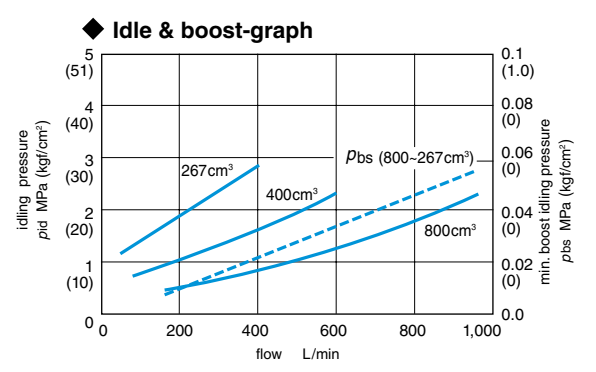
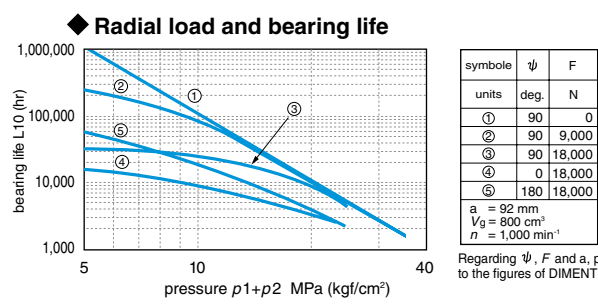
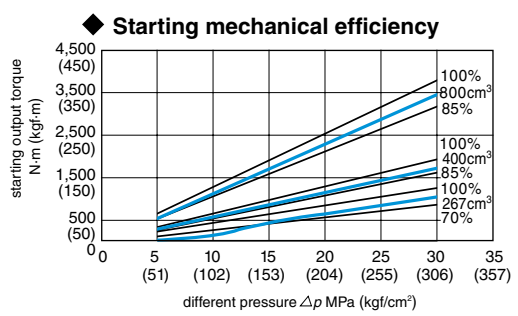
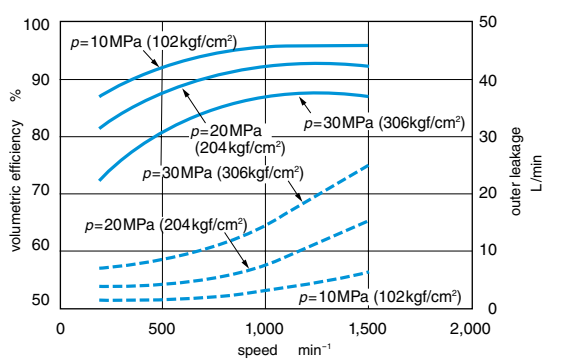
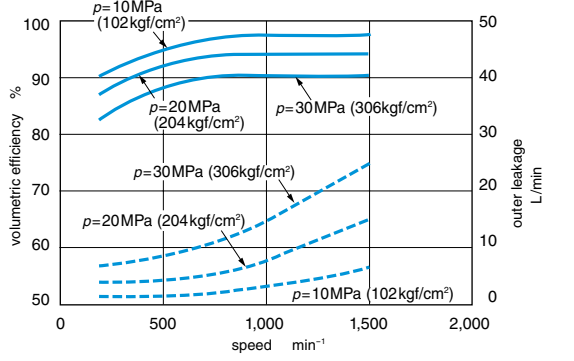
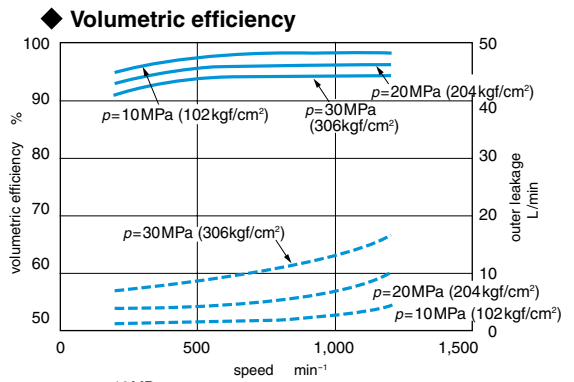
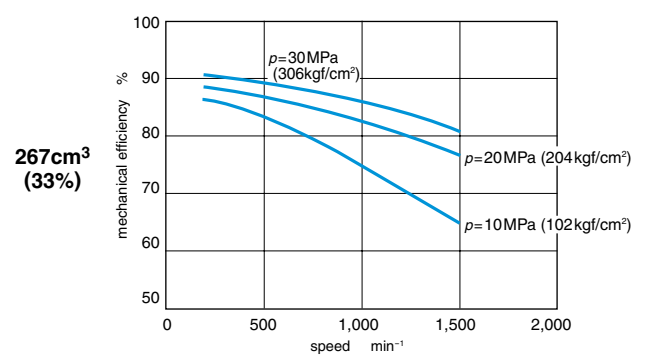
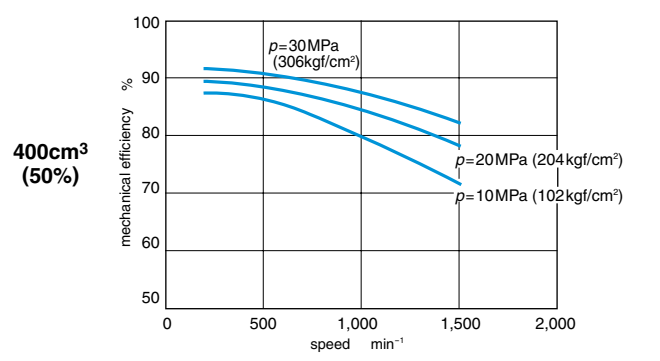
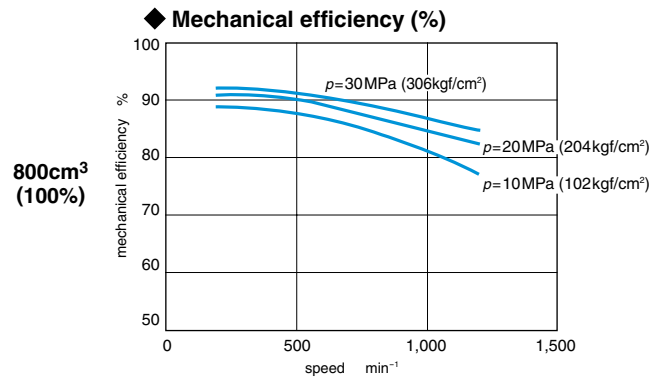

REGULATORS

Pilot Control

code	control type	control curve	function & features
1	two position negative displacement shifts (pressure control type)		Two prior set displacements are shifted negatively by varying pilot pressure. Hydraulic pressure from 2.5 to 5.0 MPa shall be provided as pilot pressure.
2	two position negative displacement shifts (elctorical control type)		Two prior set displacements are shifted negatively by varying voltage. Hydraulic pressure from 2.5 to 5.0 MPa shall be provided as pilot pressure.
3	two position negative displacement control		Displacement is determined between two prior set volumes in inverse proportion to electric current. Hydraulic pressure from 4.0 to 5.0 MPa shall be provided as pilot pressure. Standard set conditions: ① 356mA (1.2 MPa), Vg.1 (100%) ② 644mA (3.5 MPa), Vg.2 (33%)
4	three position negative displacement control		Displacement is determined among three prior set volumes in inverse proportion to electric current. Hydraulic pressure from 4.0 to 5.0 MPa shall be provided as pilot pressure. Standard set conditions: ① 319mA (0.9 MPa), Vg.1 (100%) ② 393mA (1.5 MPa), Vg.x (50%) ③ 581mA (3.0 MPa), Vg.x (50%) ④ 626mA (3.4 MPa), Vg.2 (33%)
5	two position positive displacement shifts (elctorical control type)		Two prior set displacements are shifted positively by varying voltage. Hydraulic pressure from 2.5 to 5.0 MPa shall be provided as pilot pressure.
6	two position positive displacement control		Displacement is determined between two prior set volumes in proportion to electric current. Hydraulic pressure from 4.0 to 5.0 MPa shall be provided as pilot pressure. Standard set conditions: ① 100mA (3.5 MPa), Vg.2 (33%) ② 509mA (1.2 MPa), Vg.1 (100%)
7	three position positive displacement control		Displacement is determined among three prior set volumes in proportion to electric current. Hydraulic pressure from 4.0 to 5.0 MPa shall be provided as pilot pressure. Standard set conditions: ① 156mA (3.4 MPa), Vg.2 (33%) ② 244mA (3.0 MPa), Vg.x (50%) ③ 469mA (1.5 MPa), Vg.x (50%) ④ 539mA (0.9 MPa), Vg.1 (100%)

(Note1) The regulator in M3B motor operates choosing the higher pressure port between A and B port. If the servo pressure does not hold more than 2 MPa, servo pressure must be provided.

If you need to shorten the time of shifting displacement, proper servo pressure must be provided. (Refer to below fig.)

(Note2) Pilot control section in M3B motor controls pilot second pressure negatively.

Negative displacement control of Code No.2-4 may be conducted by providing pilot second pressure directly without using solenoid operated switching valve or solenoid operated proportional valve.

(Note3) Small displacement instruction must be provided on the pilot control side before using automatic control operation. Automatic control operation precedes pilot control operation.

(Note4) The automatic controller of Code No. b and c operates choosing the higher pressure port between A and B port.

The regulator operated by the differential pressure p_{1-2} is also available as optional function and if necessity arises, please contact us.

Automatic Control

code	control type	control curve	function & features
a	without automatic control	—	—
b	sequence control		During small displacement operation, when the load increases and the pressure reaches to a certain point, the motor shifts into large displacement operation. Since then the motor maintains the large displacement operation until the pressure declines to a certain point. Standard set conditions: $p_{2-1} = 25$ MPa, $p_{1-2} = 4.3$ MPa
c	constant horsepower control		Displacement varies in order to maintain the pressure in line with the load. The motor maintains small displacement operation until the pressure increases to a certain point, and then shifting into a large displacement operation. Standard set conditions: $p_{2-1} = 25$ MPa

Tilting time, pressure related

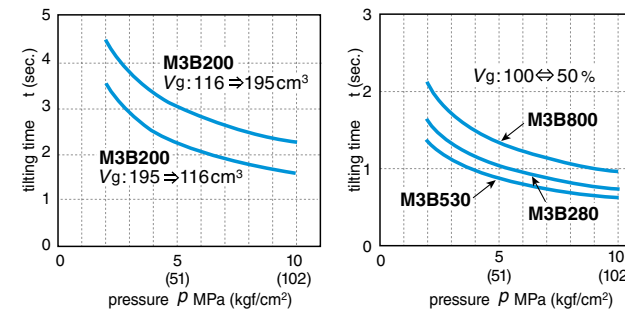

Solenoid operated switching valve specifications

max. pressure	13.7MPa
rated voltage	DC24V
rated consuming electric power	≤ 17W (24V, 20°C)
standard connector	Mitsubishi Cable Co., Z02M-GY (2P)

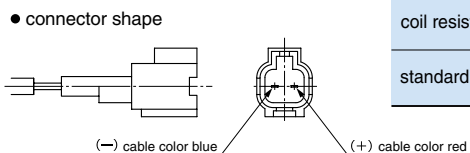

Solenoid operated proportional valve specifications

max. pressure	13.7MPa (3.9MPa in case of inverse proportion)
rated electric current	700mA
recommended dither power	80Hz/200mA _{P-P}
coil resistance value	17.5Ω (20°C)
standard connector	Mitsubishi Cable Co., Z02M-GY (2P)

M3B200 Regulators

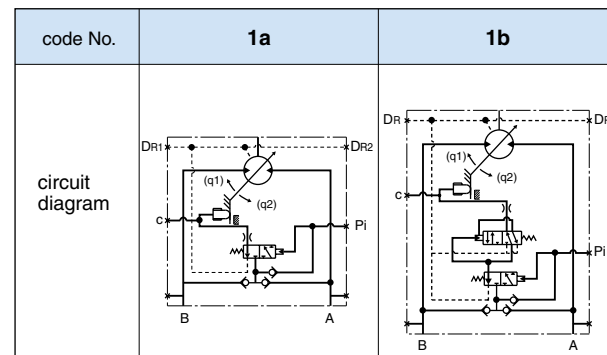

M3B280, 530, 800 Regulators

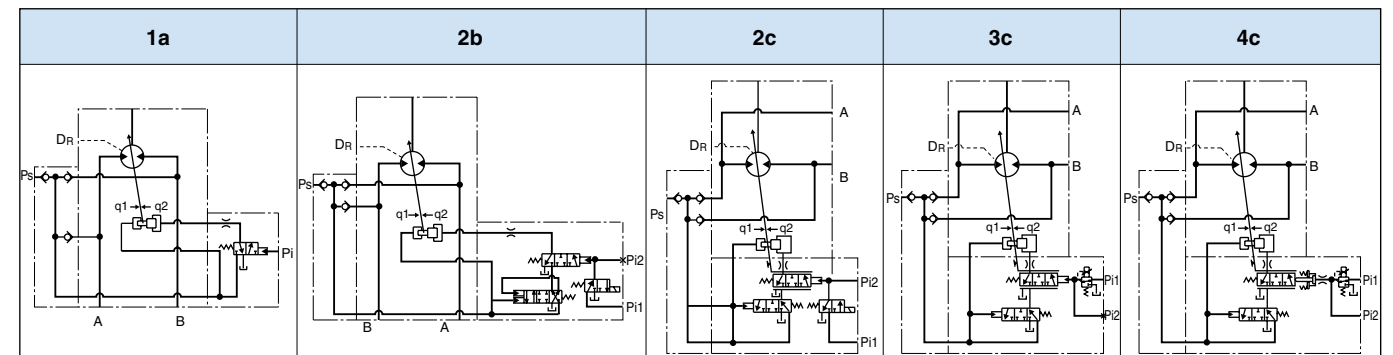

VARIOUS VALVES to CONTROL MOTORS

Various control valves, attachable direct to flanges of M3X/M3B series, are available.

(Note) Some combinations of motors and valves need conversion plates.

Swing control valve

KSC

◆KSC19

Swing control valve of neutral free type.

Valve specifications

max. pressure	30.9MPa (315kgf/cm ²)
rated flow	200 L/min
set pressure range of main relief valve	14.7~30.9MPa (150~315kgf/cm ²)
allowable back pressure	1.5MPa (15kgf/cm ²)
pilot pressure	0.29~2.51MPa (3~25.6kgf/cm ²)

PA, PB, P_{IA}, P_{IB}, P_P : G1/4
P, P_G, R : G3/4

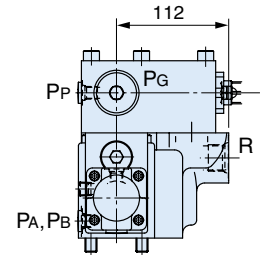
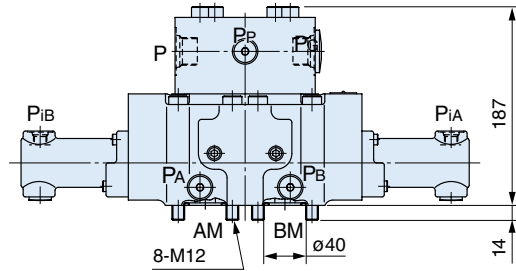
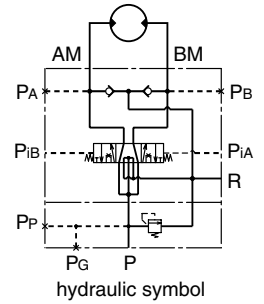
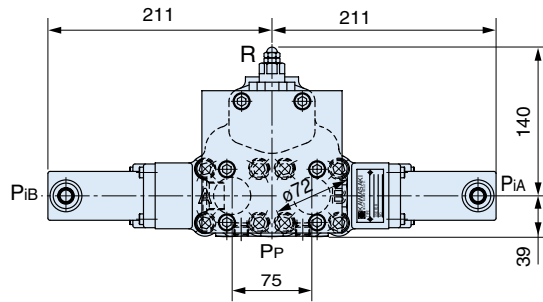

◆KSC19L

Swing control valve able to switch neutral free and lock.

Valve specifications

max. pressure	30.9MPa (315kgf/cm ²)
rated flow	200 L/min
set pressure range of main relief valve	14.7~30.9MPa (150~315kgf/cm ²)
allowable back pressure	1.5MPa (15kgf/cm ²)
spool spring force (free)	0.5~1.6MPa (150~315kgf/cm ²)
spool spring force (lock)	0.5~2.4MPa (5~16kgf/cm ²)
switch operation pressure of port relief	2.5~4.9MPa (25~50kgf/cm ²)
pressure for free mode switch port (P _{io})	(P _{io})max.+ 2.9MPa (30kgf/cm ²) ~

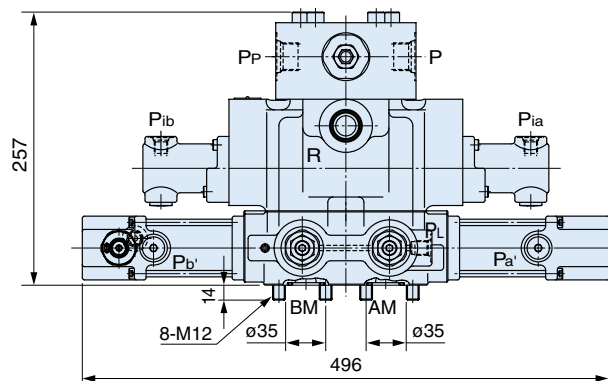
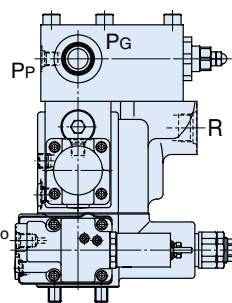
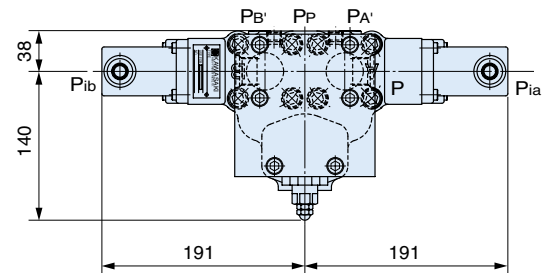
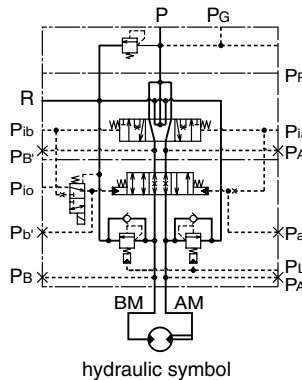

Solenoid valve specifications

max. pressure	8.3MPa (85kgf/cm ²)
leakage	~ 36cc/min (at 28cst, 2.9MPa(30kgf/cm ²))
solenoid rated voltage	DC24V
voltage variation range	20.4~29V
with anti surge	

PA, PB, P_{A'}, P_{B'}, P_A, P_B, P_{IA}, P_{IB}, P_{IO}, P_P : G1/4
P, P_G, R : G3/4

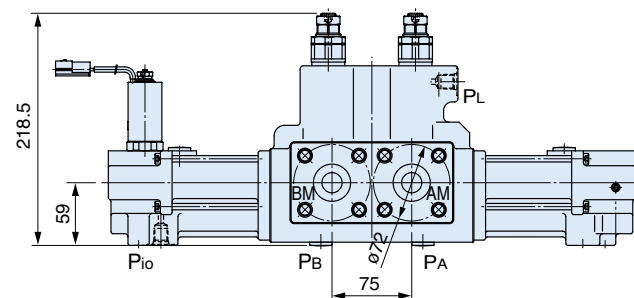

Counter balance valve for winch

KDC

◆KDC28MR

Applicable to M3X/B 200

Valve specifications

max. pressure	34.3MPa (350kgf/cm ²)
max. flow	350 L/min
set pressure of relief valve (at 30L/min)	14.7~30.9MPa (150~315kgf/cm ²)
cracking pressure of spool	0.7MPa (7kgf/cm ²)
cracking pressure of check valve	0.7MPa (7kgf/cm ²)

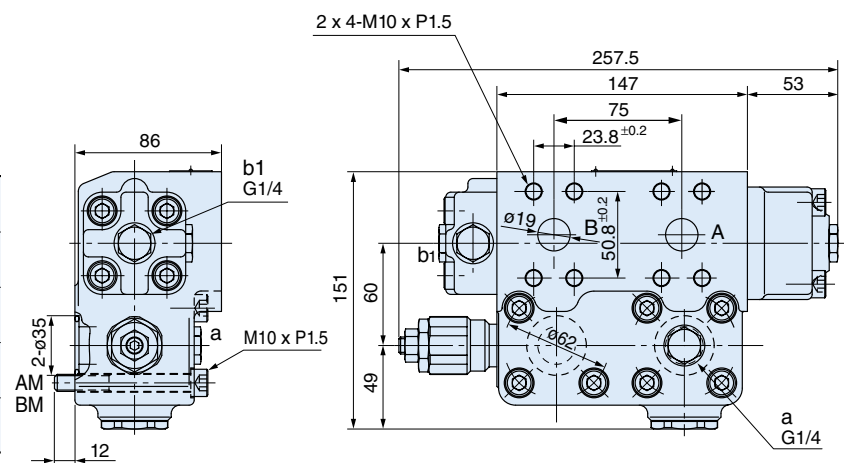

◆KDC30MR

Applicable to M3X/B 200, 530, 800

Valve specifications

max. pressure	34.3MPa (350kgf/cm ²)
max. flow	500 L/min
set pressure of relief valve (at 30L/min)	34.3MPa (350kgf/cm ²)
cracking pressure of spool	0.7MPa (7kgf/cm ²)
cracking pressure of check valve	0.03MPa (0.3kgf/cm ²)

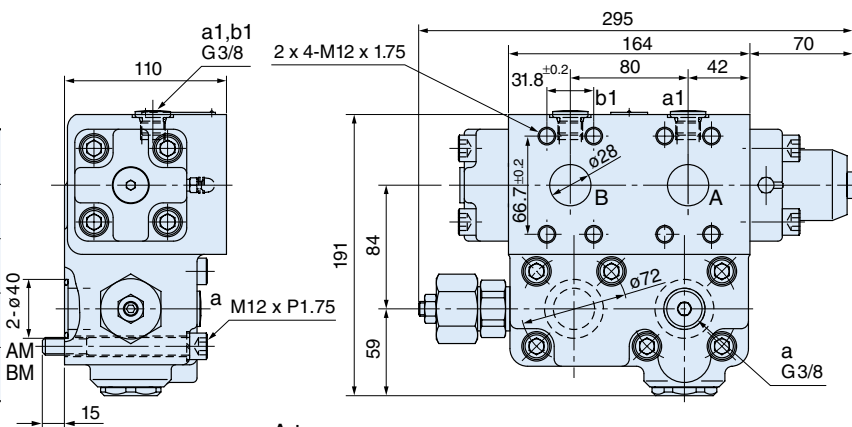

● A type

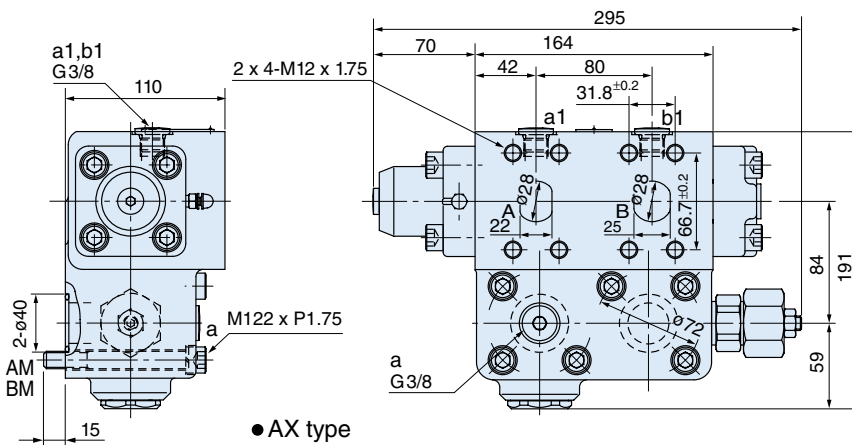
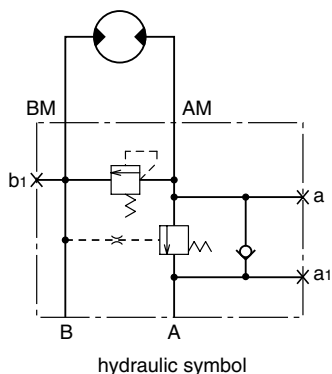

● AX type

Reverse connection type of A type

◆KDC40MR

Applicable to M3X/B 530, 800

Valve specifications

max. pressure	34.3MPa (350kgf/cm ²)
max. flow	780L/min
max. flow of relief valve	300L/min
set pressure of relief valve (at 0.4~0.6L/min)	27.5MPa (280kgf/cm ²)
cracking pressure of spool	0.69MPa (7kgf/cm ²)
cracking pressure of check valve	0.03MPa (0.3kgf/cm ²)

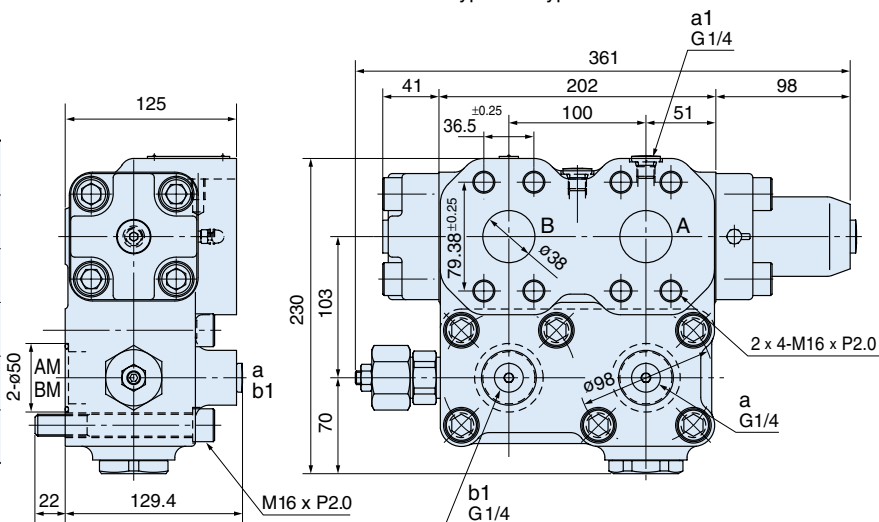

Counter balance valve for driving

B

Built-in shock-less relief valve enables smooth deceleration. This valve also automatically releases negative break in motor.

◆ B25C

Applicable to M3X/B 530, 800

Valve specifications

rated flow	240 L/min
max. flow	350 L/min
max. pressure	30.9MPa (315kgf/cm ²)
set pressure of relief valve	Ps=30.9MPa (315kgf/cm ²)
spool shifting pressure	cracking : 0.91MPa (9.3kgf/cm ²) reset : 0.78MPa (8.0kgf/cm ²)

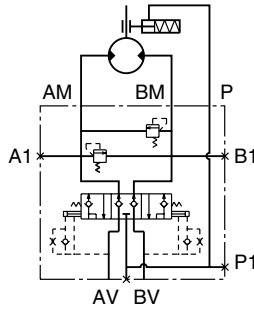

hydraulic symbol

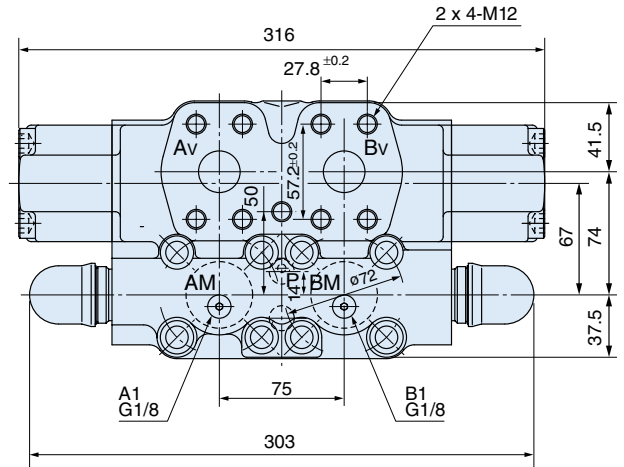
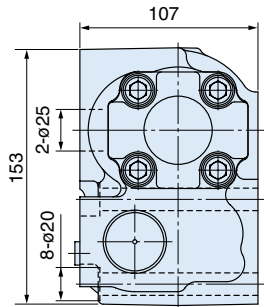
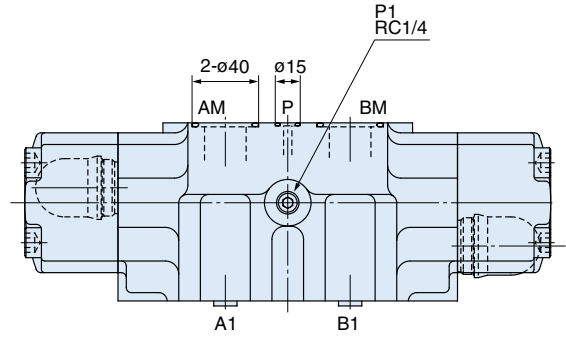

◆ B35C

Applicable to M3X/B 530, 800

Valve specifications

rated flow	380 L/min
max. flow	500 L/min
max. pressure	34.3MPa (350kgf/cm ²)
set pressure of relief valve	Ps=36.3MPa (370kgf/cm ²)
spool shifting pressure	cracking : 0.78MPa (8.0kgf/cm ²) reset : 0.69MPa (7.0kgf/cm ²)

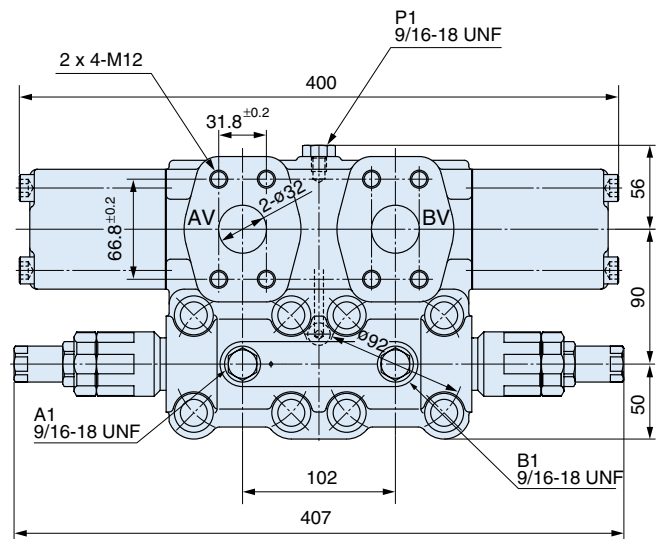
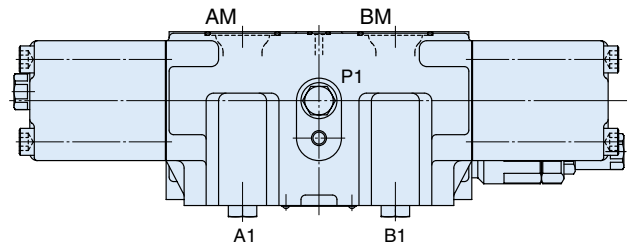
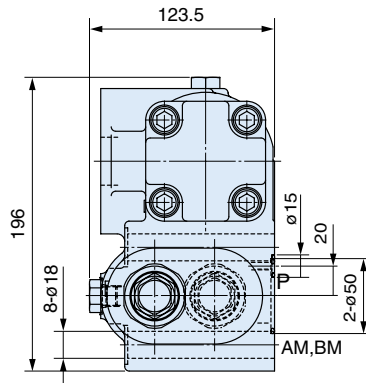

Flushing valve

FV

This valve charges the low pressure port with working oil in closed circuit and prevents rise in temperature of the working fluid.

◆ FV30

Valve specifications

max. pressure	37.8MPa (385kgf/cm ²)
max. flow	275 L/min
set pressure of high pressure relief	34.3MPa (350kgf/cm ²)
set pressure of low pressure relief (at 70L/min)	1.8MPa (18kgf/cm ²)
spool shifting pressure	2.0MPa (20kgf/cm ²)

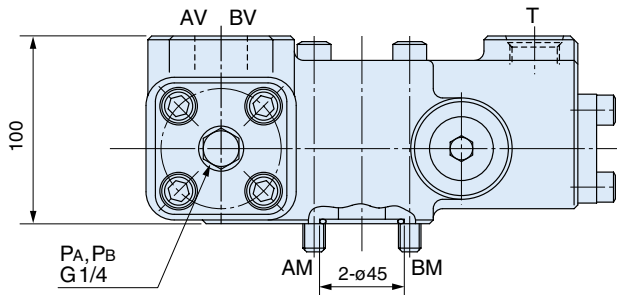
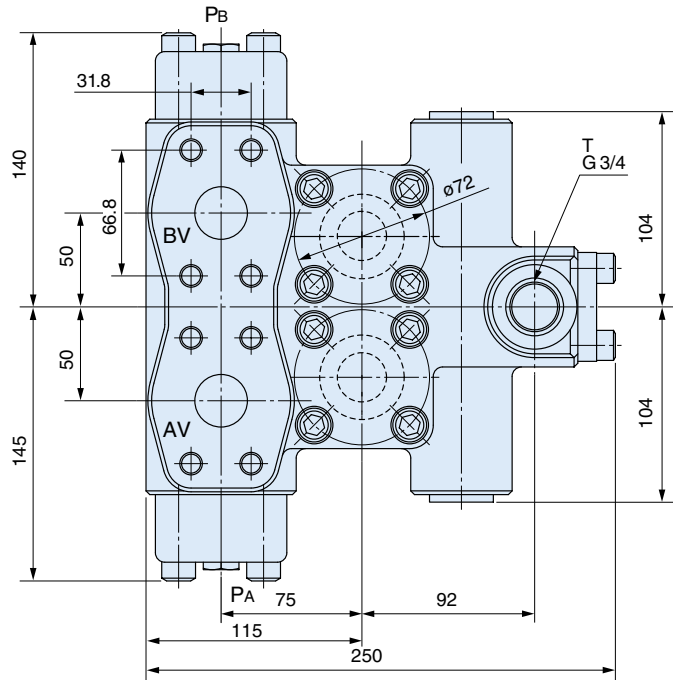
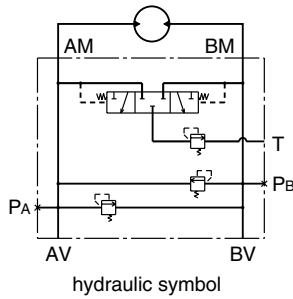

Check valve block

VB

This valve prevents cavitation.

◆ VBS-199

Valve specifications

max. pressure	34.3MPa (350kgf/cm ²)
max. flow	780 L/min
cracking pressure of check valve	0.03MPa (0.3kgf/cm ²)

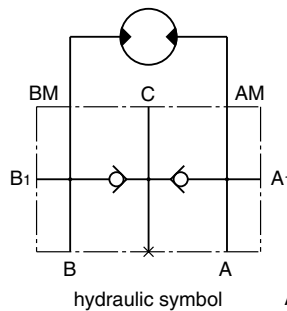

A, B, A1, B1, C : G1

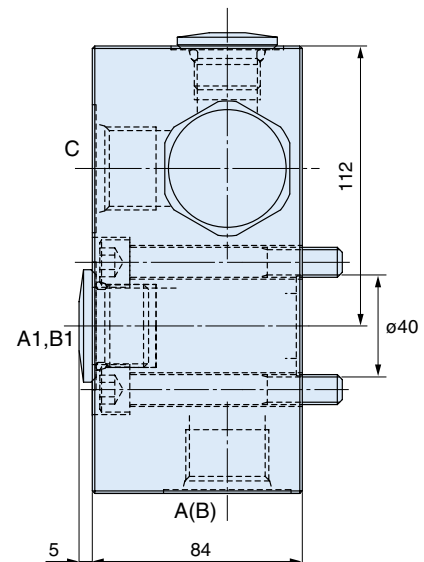
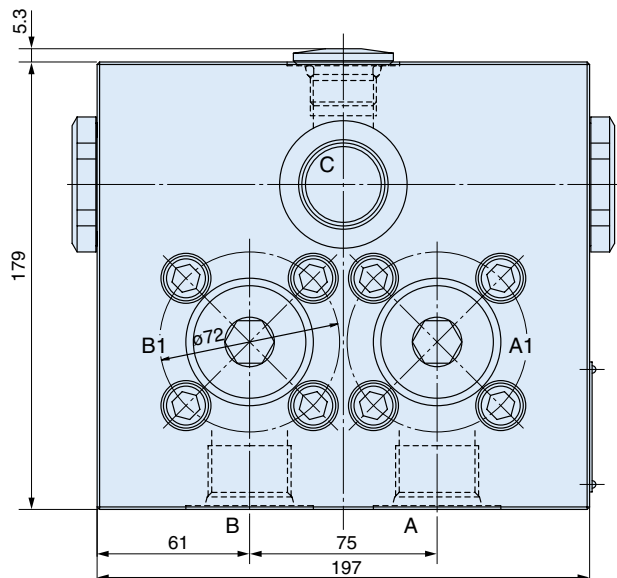

M3X/M3B-RG Series

● SPECIFICATIONS

model		M3X200-RG03S5.7	M3X280-RG06S6.4	M3X530-RG10S5.7	M3X800-RG16S6.4
			M3B280-RG06S6.4	M3B530-RG10S5.7	M3B800-RG16S6.4
displacement	cm ³	149	252	533	800
rated pressure	MPa (kgf/cm ²)	21.9 (223)	20.6 (210)	20.6 (210)	19.6 (199)
max. speed	min ⁻¹	270	190	150	130
max. flow	L/min	230	310	450	670
theoretical output torque	N·m	2,930	5,280	9,870	16,000
gear ratio		5.65	6.40	5.65	6.4
total displacement	cm ³	840	1,610	3,010	5,120
allowable radial force	L	58,800	88,300	118,000	157,000
load point	mm	89	95	113	126
mass	kg	98	150	243	420

■ Max. pressure and Max. speed are determined by RG specification. Please make sure the temperature of the RG shall not rise beyond 80°C.

■ If the motor is used for the short operating periods such as used as winch motor and so on, the operating conditions may be beyond the rated pressure or max. speed mentioned above.
In this case please inform us of the specific operating conditions.

■ The theoretical radial force W acting on the driving shaft is calculated by the following formula.

$$W = \frac{2 \times T \times 10^3 \text{ N}}{m \times Z \times \cos \alpha}$$

T : theoretical output torque N·m
 m : module mm
 Z : number of teeth
 α : standard pressure angle of cutter deg.

■ Allowable theoretical force shown in the table depends on the distance of load center from mount flange.

● BEARING LIFE

■ The life obtained in this graph is for the speed of 50 min⁻¹ and the load point of ℓ (spline center)

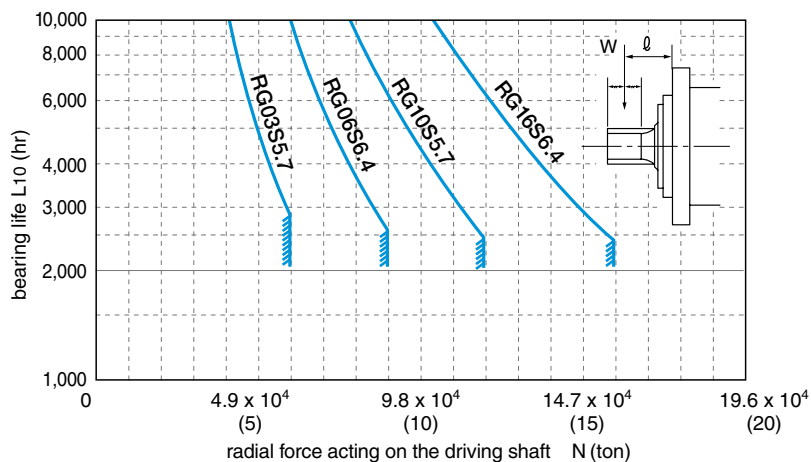

(Note 1) The bearing life is in inverse proportion to the speed.

(Note 2) If ℓ is larger, the bearing life becomes shorter.

Other caution

(Note 1) The life of the gears is influenced by the operating pressure.
Please consult us, if necessary.

(Note 2) Use gear oil equivalent to GL-3 or GL-4 of API classification.

DIMENSIONS

[M3X*****-RG]

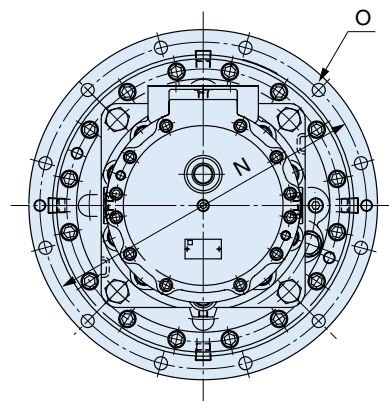
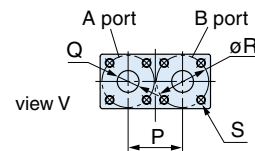
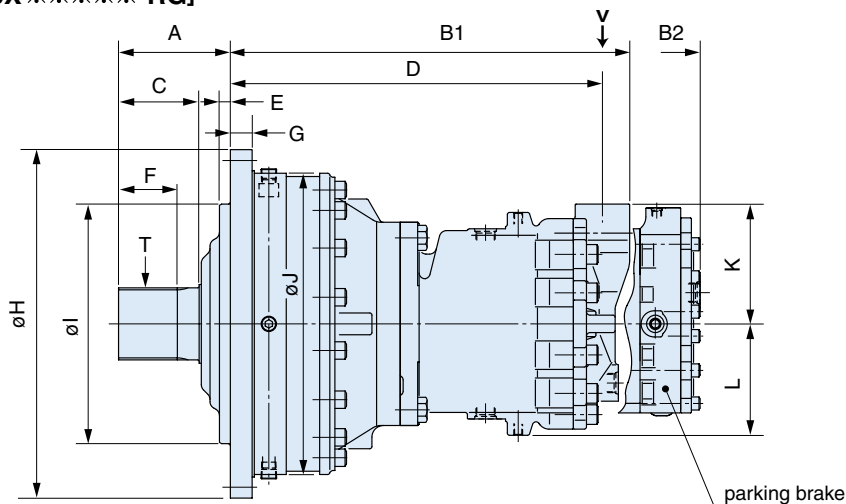

fit with parking brake

[M3B*****-RG]

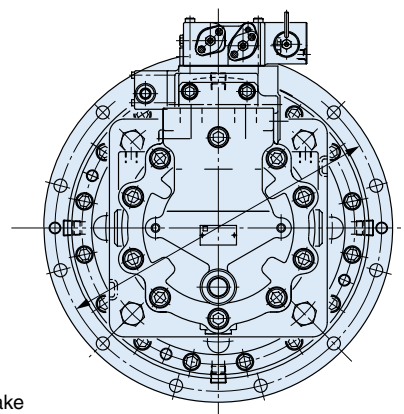
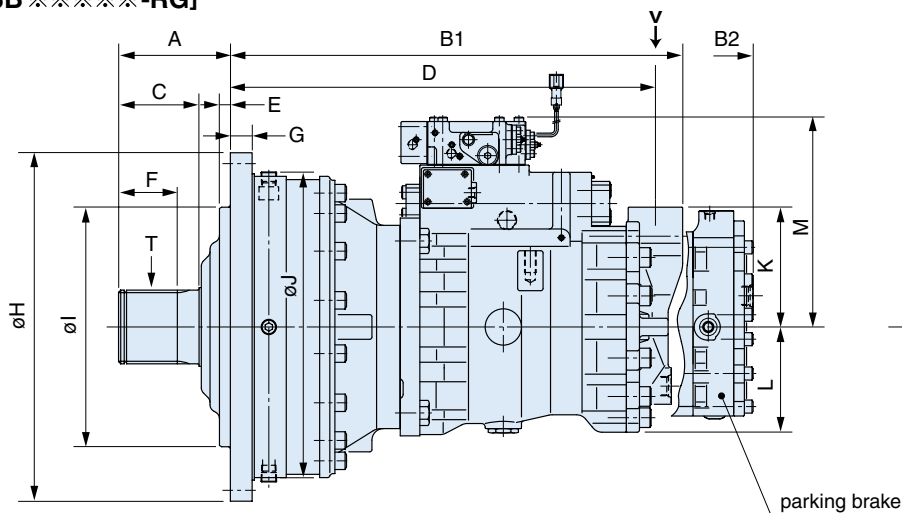

no parking brake

(mm)

size	A	B1	B2	C	D	E	F	G	H	I	J	K	L	M	N
M3X200AP-RG03S5.7	119	443	—	85	405	13	60	22	360	260 f7	268	122	103	—	320
M3X280*P-RG06S6.4 M3B280*P-RG06S6.4	130	501 549	569 616	95	463 511	14	70	25	394	320 f7	318	130	117	— 255	360
M3X530*P-RG10S5.7 M3B530*P-RG10S5.7	154	550 623	550 720	111	513 586	15	81	30	480	330 f7	415	165	154	— 289	450
M3X800AP-RG16S6.4 M3X800BP-RG16S6.4	164	623	739	108	586 598	20	75	179	460	380 f7	460	178	169	—	424
M3B800AP-RG16S6.4 M3B800BP-RG16S6.4	201	655	771	141	618 630	15	114	32	570	390 f7	464	178	169	332	520

size	O	P	Q	R	S	T
M3X200AP-RG03S5.7	6-ø22 (6 x 60°)	75	25	72	2 x 4-M12 x 1.75	m=2.5, z=20 (JIS D2001)
M3X280*P-RG06S6.4 M3B280*P-RG06S6.4	10-ø22 (10 x 36°)	75	25	72	2 x 4-M12 x 1.75	m=2.5, z=20 (JIS D2001)
M3X530*P-RG10S5.7 M3B530*P-RG10S5.7	12-ø18 (12 x 30°)	75	30	72	2 x 4-M12 x 1.75	m=3.75, z=26 (JIS D2001)
M3X800AP-RG16S6.4 M3X800BP-RG16S6.4	16-ø20 (16 x 22.5°)	75 102	30 32	72 92	2 x 4-M12 x 1.75 2 x 4-M16 x 2	m=3.75, z=29 (JIS D2001)
M3B800AP-RG16S6.4 M3B800BP-RG16S6.4	12-ø22 (12 x 30°)	75 102	30 32	72 92	2 x 4-M12 x 1.75 2 x 4-M16 x 2	DP=6/12, z=26 (SAE)

Counter balance valve KDS30MR or brake valve B25C is directly attachable to M3 series motors.

K3X Series

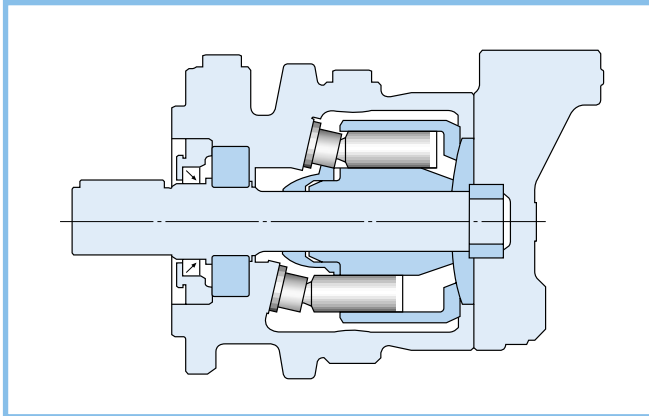

The K3X series are newly developed motors for industrial machinery.

The design is based on technology and experience of current K3V series for construction machinery or industrial machinery.

FEATURES

1. High Efficiency and Reliability

K3X series has high efficiency and high reliability by using common rotary parts of K3V Series pumps which are used widely for construction machines and have many years of experience.

2. Allowable to Apply The Radial Force

The motor shaft can withstand radial loads. But in this case, bearing life decrease.

3. Allowable to Use on Upward Motor Shaft Position

The motor has the drain port to be installed with shaft vertical.

ORDERING CODE

K3X 112 S-100M-D1

K3X series ————

size ————

63 : 64cm³ 90 : 89cm³
80 : 82cm³ 112 : 111cm³

power code, shaft code ————

0 : standard type, key standard
1 : standard type, involute spline
5 : high power type, key
6 : high power type, involute spline

oil temp. code

marks	oil temperature range	remarks
V2	90°C < θ °C	all seal parts: fluoro-rubber
V1	90°C ≥ θ °C	oil seal: fluoro-rubber
blank	-20°C ≤ θ ≤ 90°C	
D1	-30°C < θ < -20°C	
D3	-45°C ≤ θ ≤ -30°C	

valve cover code and direction of rotation (A port :high press., view from shaft end)

0 : split flange and clockwise rotation standard
1 : thread flange and clockwise rotation
2 : split flange and anti-clockwise rotation
3 : thread flange and anti-clockwise rotation

DIMENSIONS

[M3X112S]

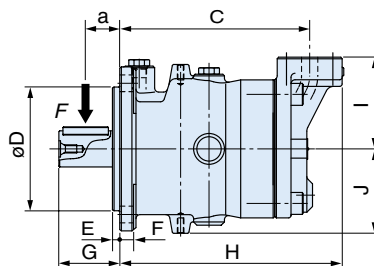
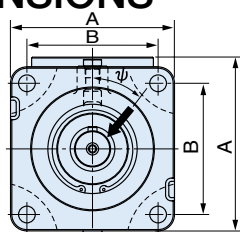

Main flange

split type

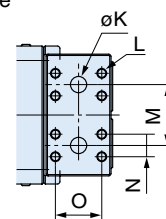

thread type

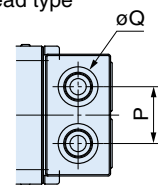

(mm)

size	A	B	C	øD	E	F	G	H	I	J	øK	L	M	N	O	P	Q
K3X63	146.5	114.5	198	127	12.7	14	55.5	234	102	91	16	M10	66	23.8	50.8	66	SAE3/4",1-1/16"-12UN-2B
K3X80/90/112	202.0	161.6	234	152.4	9.0	17	75.0	276	113	104	20	M12	75	27.8	57.2	70	SAE1",1-5/16"-12UN-2B

SPECIFICATIONS

model	standard type				high speed type					
	K3X63	K3X80	K3X90	K3X112	K3X63	K3X80	K3X90	K3X112		
displacement	Vg cm ³		63	82	89	111	51	82	89	111
pressure MPa (kgf/cm ²)	rated	31.4 (320)* ¹				31.4 (320)* ¹				31.4(320)* ²
	max.	34.3 (350)				34.3 (350)				
max. speed	n max	min ⁻¹	2,400	2,200		3,000		3,000		3,000* ²
max. flow	L/min		152	181	200	244	153	247	268	333
rated torque	N·m		316	411	450	554	255	411	446	554
rated power	kW		79	95	100	128	80	129	140	174
case volume	L		0.3	0.5		0.3	0.5			
moment of inertia	N·m ²		0.3	0.6		0.3	0.6			
mass	kg		23	40		23	40			

*1 For K3X63S with key type shaft, rated pressure is 24.5 MPa (250 kgf/cm²).

*2 In case that the motor is used at the max. speed of 3,000min⁻¹, rated pressure is 25.1 MPa (255 kgf/cm²), and at the rated pressure of 31.4 MPa (320 kgf/cm²), max. speed is 2,400min⁻¹.

PERFORMANCE CURVE

oil temperature : 50 °C

oil viscosity : 32mm²/s

[M3X112]

The values given in the below figures are mean ones, and not guaranteed ones.

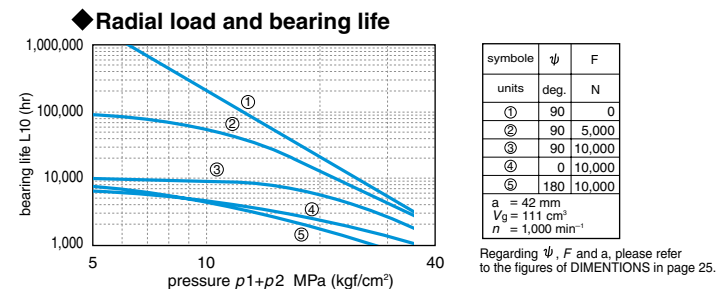
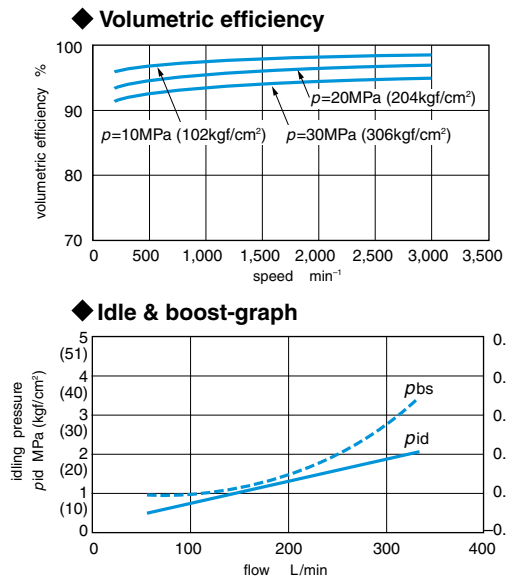
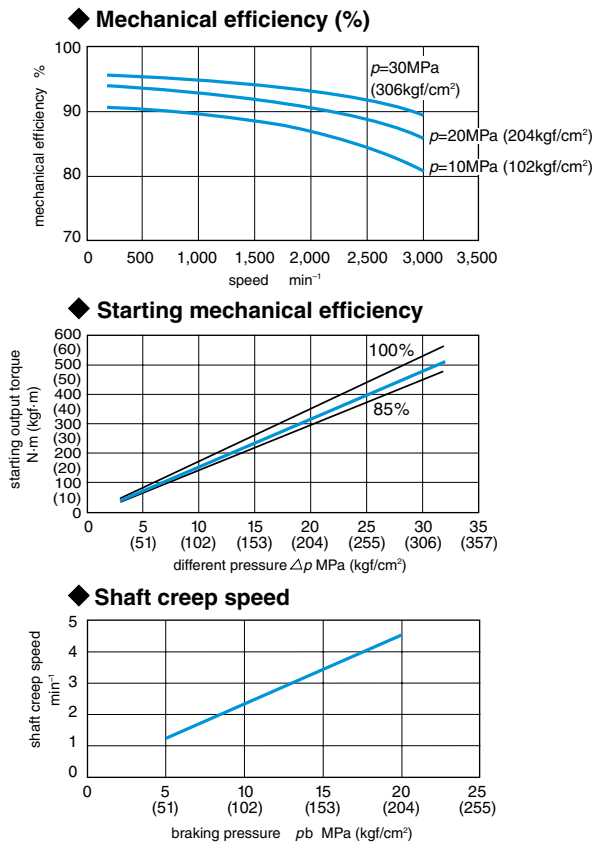

Bearing life

The calculated life (B₁₀ life) shown in the graph is for speed No=1,000min⁻¹. Calculation of life for a random speed N is follows.

$$L = \frac{N_0}{N} \times L_0 \quad (L_0 : \text{calculated life for } N_0)$$

(Note)
p1: inlet pressure
p2: outlet pressure

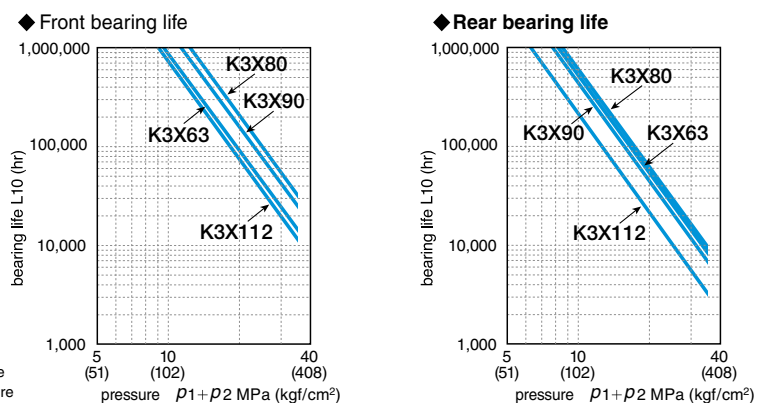

■ OPERATION PRINCIPLE

As shown in the right, the high pressure oil passes through the inlet port (a) and flows into the cylinder block (2). Hydraulic force thus acts upon the piston (4), generating an axial force F . This force F is vector-analyzed through the shoe (5) into force F_1 which is perpendicular to the swash plate (7), and force F_2 which is a vertical force with respect to the output shaft. The reaction force of force F_2 is transmitted via the piston to the cylinder block, generating a rotational force which turns the output shaft.

These are 9 equally spaced pistons in the cylinder block. The pistons connected to the high pressure inlet port transmit rotational torque sequentially to the output shaft.

Reversing the flow of operating oil causes the output shaft to rotate in reverse.

The theoretical output torque (T) is obtained by the following formula.

$$T = \frac{\Delta p \times Vg}{6.28}$$

T : Theoretical output torque N·m
 Δp : Effective pressure difference MPa
 Vg : Displacement per revolution cm³

$$1 \text{ N}\cdot\text{m} = 0.10197 \text{ kgf}\cdot\text{m} \quad 1 \text{ MPa} = 10.197 \text{ kgf/cm}^2$$

■ PARKING BRAKE (Option)

This is a negative type, oil-lubricated, multi-disc parking brake. Friction plates are cooled and lubricated by the drain oil of the hydraulic motor. The braking operation is as follows.

The friction plates (14) which are splined to the joint (11) and the separator plates (13) which are splined to the valve cover (8) are placed alternately. If not in operation, the brake piston (10) is pushed leftward by the springs (3) and the resultant friction force between the friction and the separator plates restricts the driving shaft to rotate. On the other hand, a release pressure larger than the spring force is applied to the oil chamber (15) through the release port, the brake piston (10) moves rightward and clearance is formed between the plates. So the brake is released and the driving shaft can rotate freely.

DISPLACEMENT CHANGING MECHANISM OF M3B SERIES

◆ M3B280,530,800

The semi cylindrical slide plate, positioned at the both sides of the swash plate, supports the load, as a swash plate supporting mechanism. Two control pistons push swash plate opposite to each other. Displacement is changed by controlling the oil supply to the chambers to adjust the tilting angle of the swash plate.

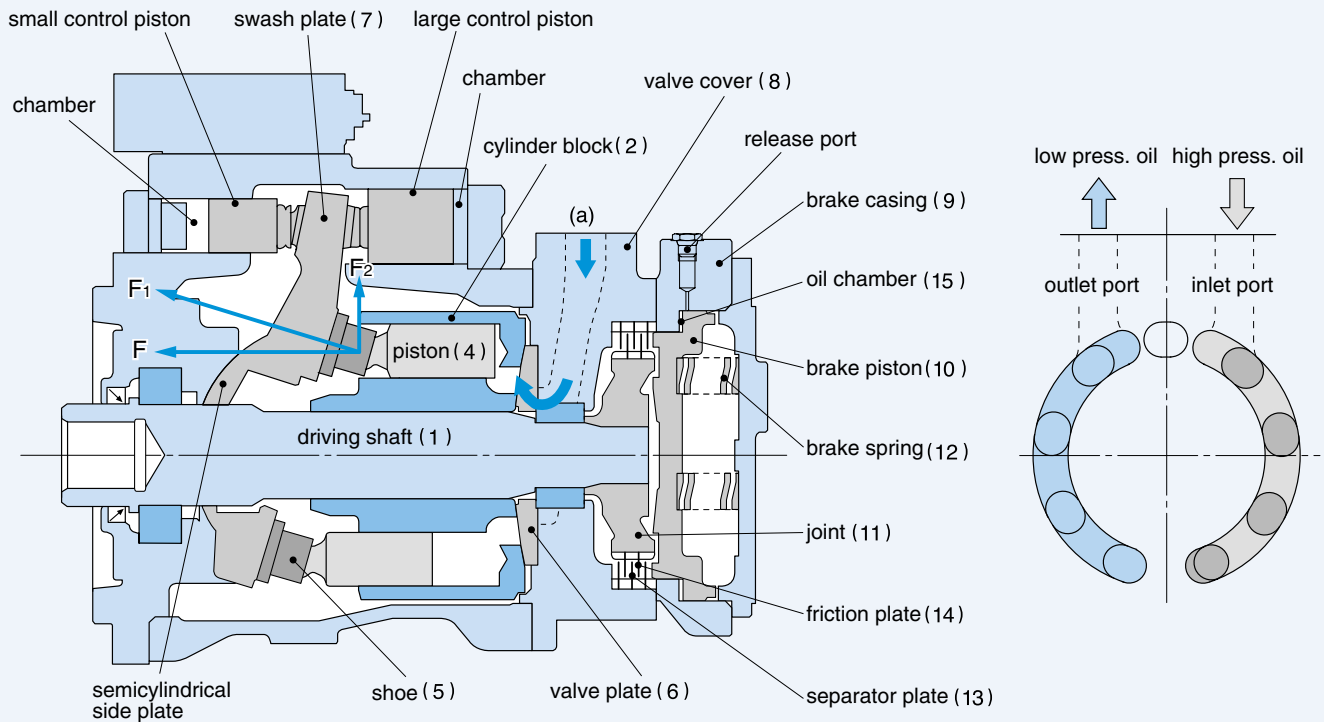

◆ M3B200

The semi spherical pivot ball, positioned at the both sides of the swash plate, supports the load, as a swash plate supporting mechanism.

The tilting angle of the swash plate diminishes by supplying the oil to the chamber of a control piston positioned at the swash plate. On the other hand, when oil is not supplied to the chamber, swash plate is retreated by the forces applied to the pistons and by the cylinder spring and the tilting angle becomes maximum.

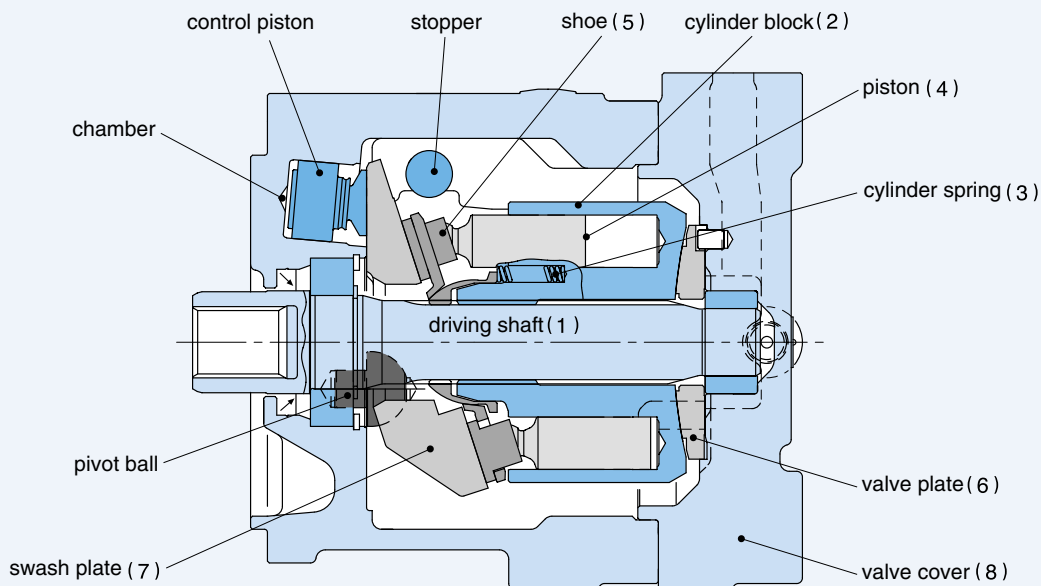

CAUTION FOR HANDLING



1. Operating fluid and temperature range

- ① Please use antiwear hydraulic fluid as operating fluid.
- ② The allowable ranges of operating fluid are as follows.
Viscosity : 10~1,000 mm²/s (cSt)
Temperature : -20~+80°C
- ③ In case of using special fluid (Phosphate ester compounds, water-glycol fluid, fatty acid ester compounds, etc.) please consult Kawasaki for instructions prior to use.



2. Filtration

For satisfactory service life of these motors application, the operating fluid should be controlled cleaner than the cleanliness level of NAS1638 Class9. Install a 10 μm filter in the return circuit of respective actuators.



3. Mounting

- ① Regarding the mounting direction, please refer to the below list. In case of the "Option" mentioned in the list, please consult
- ② Kawasaki.

Alignment should be so carried out that the parallel error may be held within ±0.05 mm.

Direction of the shaft	M3X/M3B	M3X/M3B-RG	K3X
Horizontal	Standard	Standard	Standard
Down ward	Option	Option	Option
Up ward	—	—	Standard



4. Drain piping

- ① The motor's drain port, as shown in the following figure, should be so located that the casing can be filled with oil.
- ② Use a drain tube bigger in size than the motor's port. Keep the casing pressure normally below 0.2 MPa (2 kgf/cm²) and below 0.6 MPa (6 kgf/cm²) even at the peak.

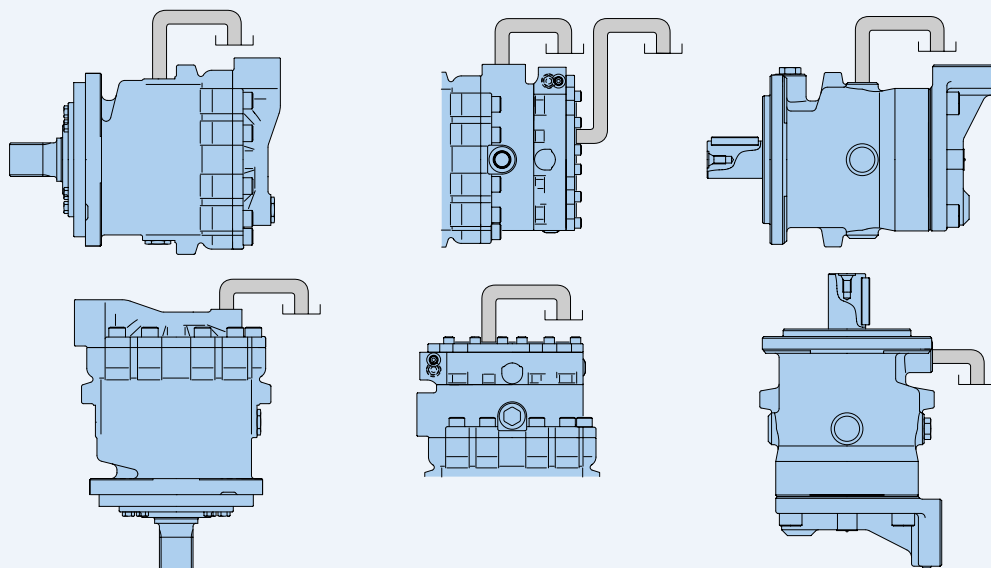



WARNING

5.Oil filling and air venting

Before operation, be sure to fill the casing with oil through the drain port . Vent all air out of the motor and hydraulic circuit prior to operation.

The insufficient amount of oil may cause the lubrication failure, resulting in the seizure of internal parts. The volume of the oil is shown in the SPECIFICATIONS as case volume.



WARNING

6.Parking brake

This brake should be used only for parking, are not for dynamic braking. In case of driving inertial load, measures such as the adoption of the time delay valve should be taken to prevent the parking brake from being activated before the inertial mass stops.



WARNING

7.Radial and thrust load

- ① Bearing life against the radial load applied to the shaft is shown in the Performance curve for each motor type. If load point or load direction is different, please consult us.
- ② Do not apply thrust load to the shaft of these motors.
- ③ Radial and thrust load may be applied to the output shaft of the reduction gears. Please refer to P23 for the relations between the radial load and the bearing life.



CAUTION

8.Cavitation

When the motor is operating in an overrunning (pumping) mode, then to prevent the occurrence of cavitation, a positive boost pressure is required at the suction port. The minimum boost pressure requirement shown in the model performance data is based on the regular operation. In case of a rapid change of the flow volume, more boost pressure must be applied.



CAUTION

9.Back pressure

The lower of the two main motor ports pressures should always be less than 2.5 MPa (25 kgf/cm²). Pressure higher than this could cause a possible reduction in motor performance. In case of any doubt please consult us.

Piping size

model	main port	drain port	pilot port, gage port, etc.
M3X200	special	G3/8	
M3X280	special	G1/2	G1/4
M3X530	special	G3/4	G1/4
M3X800A	special	G3/4	G1/4
M3X800B	special	G3/4	G1/4
M3B200	special	G1/2	G1/4
M3B280	special	G1/2	G1/4
M3B530	special	G3/4	G1/4
M3B800A	special	G3/4	G1/4
M3B800B	special	G3/4	G1/4
K3X63	SAE 3/4"	SAE 1/2"	G1/4
K3X80,90,112	SAE 1"	SAE 1/2"	G1/4
KSC19	G3/4		
KSC19L	G3/4		
KDC28MR	SAE 3/4"		G1/4
KDC30MR	SAE 1-1/4"		G3/8
KDC40MR	SAE 1-1/2"		G1/4
B25C	SAE 1"		G1/8
B35C	SAE 1-1/4"		SAE 3/8"
FV30	SAE 1-1/4"		G1/4, G3/4
VBS-199	G1		G1

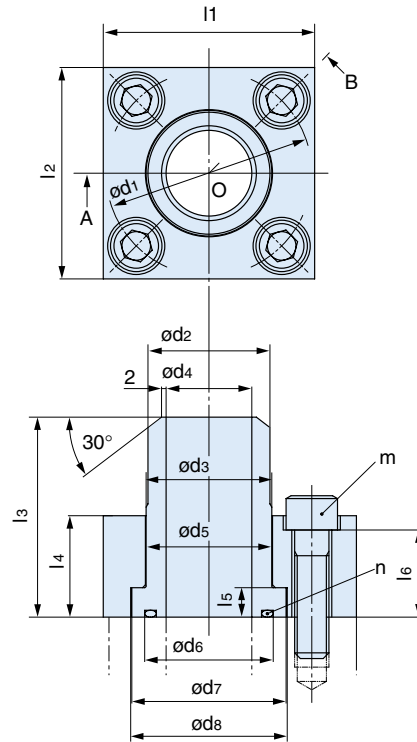

Flange for main ports

Flange for main ports

These flanges are attachable directly to the main ports of motors.

model	l1	l2	l3	l4	l5	l6	d1	d2	d3	d4	d5	d6	d7	d8	m	n	flange-sub KPM parts list (for one motor)
M3B200	64	64	60	30	8.8	25	62	34.0	35	22	35.5	35	44.5	45.2	2 X 4 X M10-40	G30	3703580-1668
M3X200 M3X/B280	74	74	60	30	9.5	25	72	34.0	38	22	38.9	40	47.6	48.4	2 X 4 X M12-45	G35	37033580-1669
M3X/B530 M3X/B800A	74	74	70	35	10.3	30	72	42.7	44	30	44.5	45	54.0	54.8	2 X 4 X M12-45	G40	37033580-1670
M3X/B800B	94	94	70	35	10.3	30	92	42.7	44	30	44.5	45	54.0	54.8	2 X 4 X M16-50	G40	37033580-1671

O-ring type thread connector

These connectors are used to convert the drain ports, pilot ports, attached valves' piping ports, etc. into PT screws.

size	T1	T2	a	b	c	d	e	f	g	h	connector KPM parts list (with o-ring)
JIS 1/4"	G1/4	RC1/4	12	17	29	5	11	19	19	P11	PSTB 1124-6
JIS 3/8"	G3/8	RC3/8	12	19	31	8	12	22	22	P14	PSTB 1124-9
JIS 1/2"	G1/2	RC1/2	16	22	38	10	15	27	27	P18	PSTB 1124-12
JIS 3/4"	G3/4	RC3/4	17	25	42	16	17	36	36	P24	PSTB 1124-19
JIS 1"	G1	RC1	21	27	48	22	19	41	41	P29	PSTB 1124-25
SAE 3/8"	9/16-18UNF	RC3/8	9.9	19	28.9	7.0	12	17.4	22	906 ^(*1)	PSTB 4043-6
SAE 1/2"	3/4-16UNF	RC1/2	11.1	22	33.1	10.0	15	22.2	26	908 ^(*1)	PSTB 4043-8
SAE 3/4"	1-1/16-12UN	RC3/4	15.0	25	40.0	15.5	17	31.7	35	912 ^(*1)	PSTB 4043-12
SAE 1"	1-5/16-12UN	RC1	15.0	27	42.0	22.0	19	38.0	41	916 ^(*1)	PSTB 4043-16

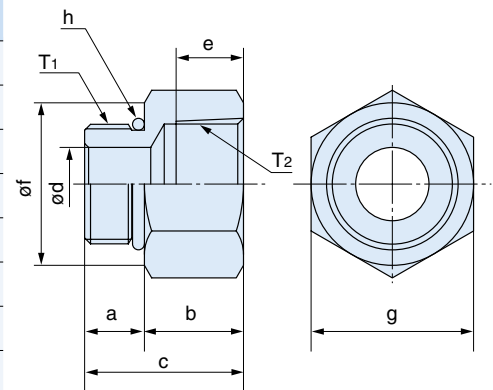

(*1) SAE AS 586

Manifold for conversion into SAE flange

These manifolds are used to convert motor main ports into SAE flanges.

model	l1	l2	l3	l4	l5	l6	l7	l8	l9	l10	l11	l12	d1	d2	d3	m	n	o	p	q	r	s	plate-sub KPM parts list (for one motor)
M3B200	150	75	100	37.5	27	9	82	14	41.0	57.2	27.8	75	62	25	35	2X4XM10-85	1" (*1)	G1/4	9/16-18UNF (*2)	G30	P11	906 (*3)	3724750-0615
M3X200 M3X/B280	150	75	102	37.5	27	9	82	16	41.0	57.2	27.8	75	72	25	35	2X4XM12-85	1" (*1)	G1/4	9/16-18UNF (*2)	G30	P11	906 (*3)	3724750-0616
M3X/B530 M3X/B800A	152	75	102	37.5	27	9	96	17	48.5	66.7	31.8	79	72	28	45	2X4XM12-100	1-1/4" (*1)	G1/4	9/16-18UNF (*2)	G40	P11	906 (*3)	3724750-0617
M3X/B800B	202	102	120	50.0	27	9	96	21	48.5	66.7	31.8	102	92	30	45	2X4XM16-100	1-1/4" (*1)	G1/4	9/16-18UNF (*2)	G40	P11	906 (*3)	3724750-0618

(*1) SAE high pressure series flange 6000 psi/metric screw

(*2) SAE 3/8"

(*3) SAE AS 586

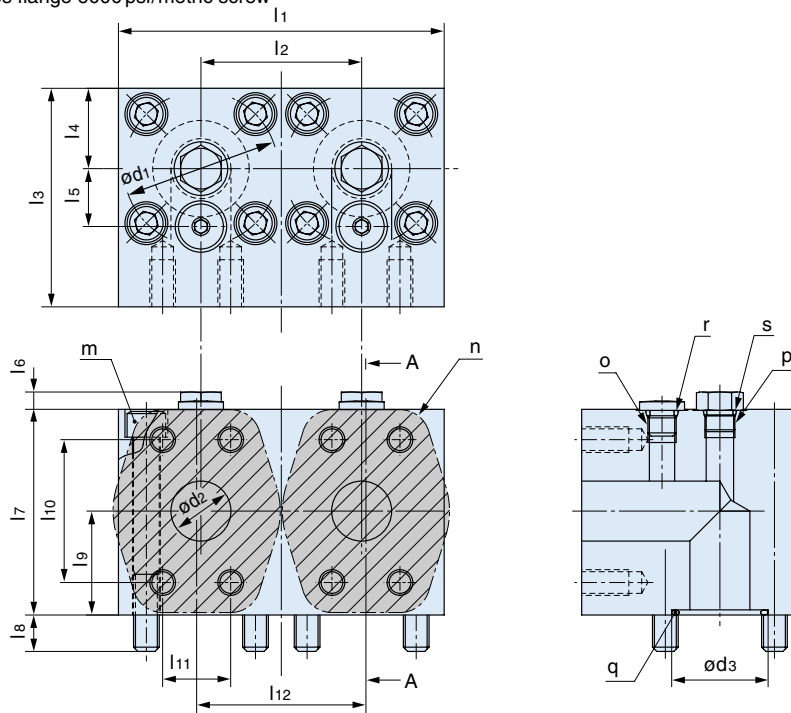

Flange for main ports (SAE standard)

These flanges are based on SAE standard. SAE conversion manifolds are necessary for M3 series.

flange size	l1	l2	l3	l4	l5	d1	d2	d3	d4	d5	d6	d7	m	n	o	flange-sub KPM parts list (for one motor)
3/4" (*1)	20	50	24	48	51	30	19	16.2	27.2	36	74	11	3/4"	4 XM10-35	G25	3703580-1804
1" (*1)	25	55	27.8	54	57.2	40	26	21.2	34.0	43	82	11	1"	4 XM10-40	G35	3703580-1805
1-1/4" (*1)	30	65	31.8	61	66.7	45	32	29.9	42.7	50	96	14	1-1/4"	4 XM12-45	G40	3703580-1806
1-1/2" (*1)	35	75	36.5	70	79.4	50	38	34.4	48.6	58	115	18	1-1/2"	4 XM16-55	G45	3703580-1807

(*1) SAE high pressure series flange (6000 psi)

