

REVERSIBLE **AUTOPACKS**

500W & 800W DC Motors

Versatile range of micro power units for mobile applications.

Flows to 3,6l/min; Pressures to 180bar

Motors 150W, 200W, **500W & 800W** dc or 200W ac

Pump sizes 0,25, 0,50 & 0,75cc/rev

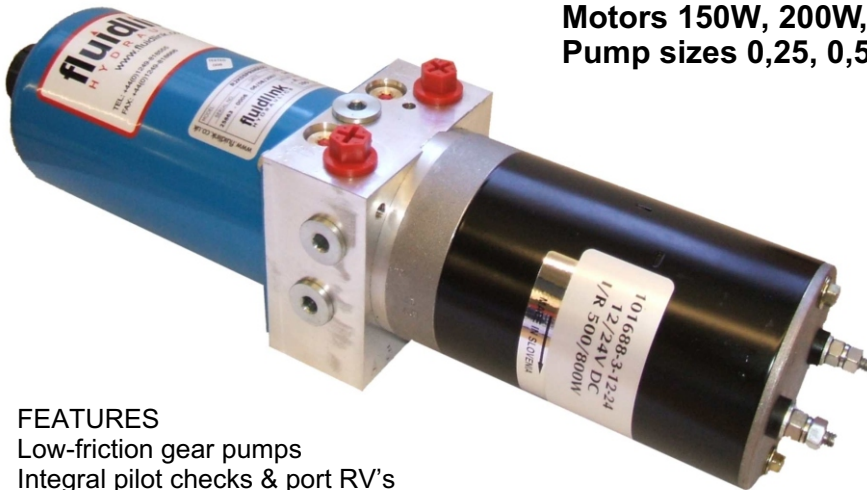

FEATURES

- Low-friction gear pumps
- Integral pilot checks & port RV's
- Reversible action eliminates directional valve
- Quiet operation with long life
- Easy to install with integral mounting points
- Wide range of options
- Customised OEM versions available
- Global support & servicing

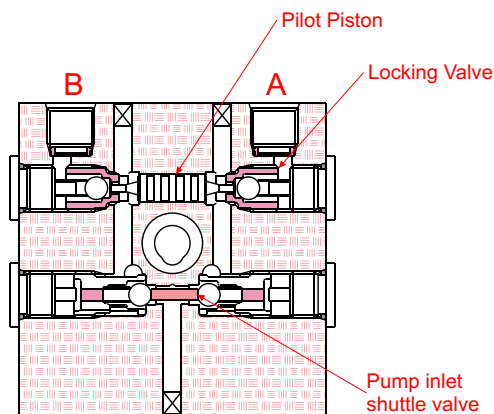
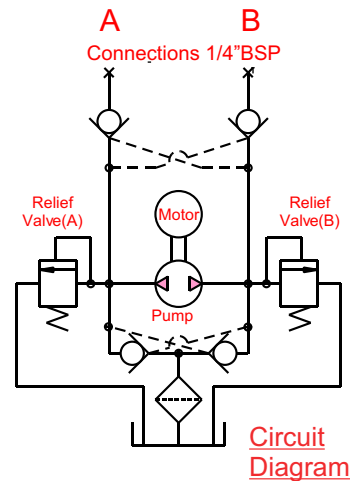

Section through **Autopack** showing (top) Integral Pilot Checks and (below) the suction valve shuttle which allows oil to circulate through the pump.

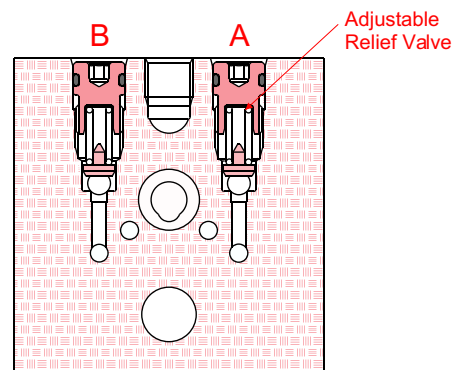

Secondary section through **Autopack** showing Integral Relief Valves allowing individual pressure setting for each port.

REVERSIBLE **AUTOPACKS**

500W & 800W DC Motors

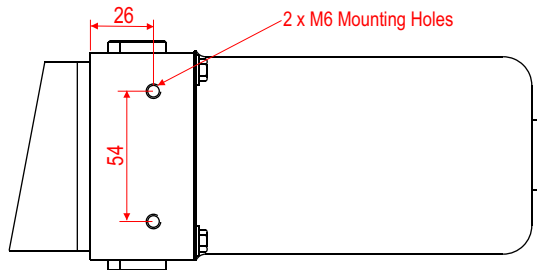
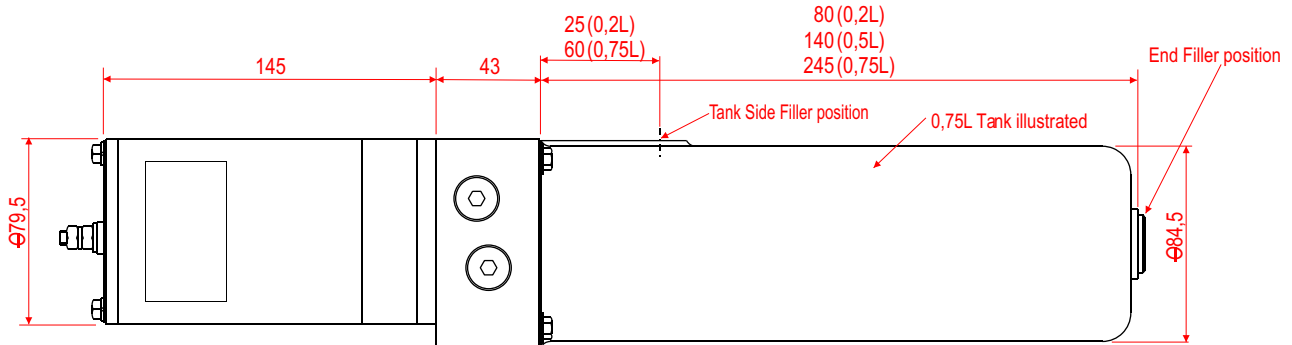

Underside of Autopack (0,5L Tank shown)
 Note- when used vertically tank must be uppermost
 When horizontal, mounting face must be lowest.

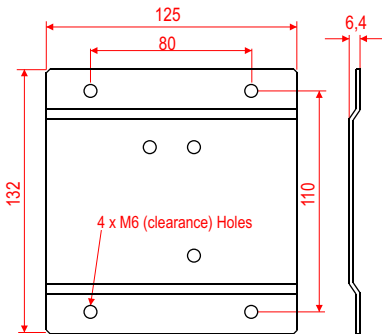

Mounting Plate 101876

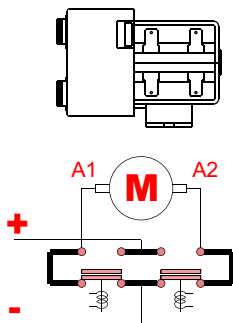
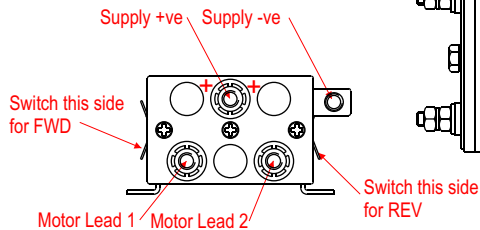
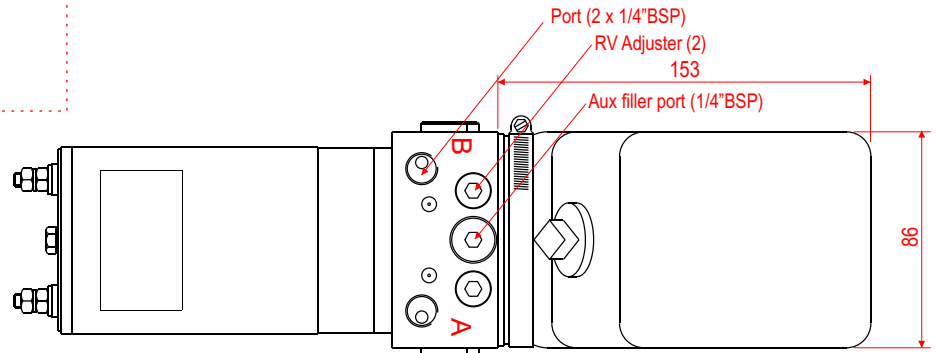

Reversing Starter KSWR01A**

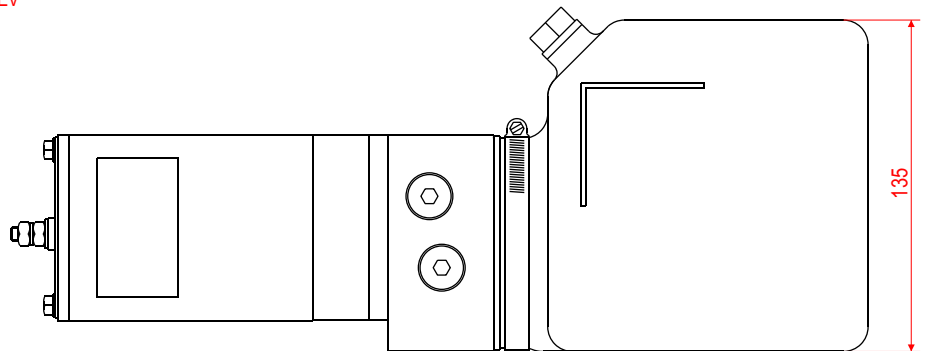

Autopack ,with 1,0L Tank
 Note- can only be used horizontally

PERFORMANCE DATA REVERSIBLE **AUTOPACKS**

500/800W Reversible Motors

Nominal performance of pack combinations at constant voltage and at nominal 20°-25° C with ISO VG22 oil.

Key to diagrams:-

(Black) Flow rate (Q) 800W motor
 (Red) Current (A) 800W motor
 (Blue) S2 run time (S) 800W motor

(Black) Flow rate (Q) 500W motor
 (Red) Current (A) 500W motor
 (Blue) S2 run time (S) 500W motor

12V Motor

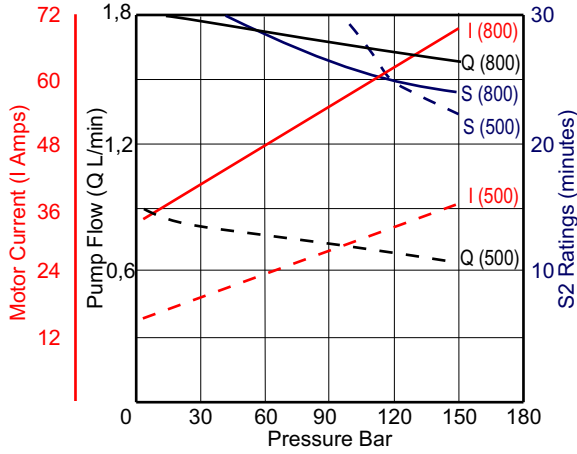

24V Motor

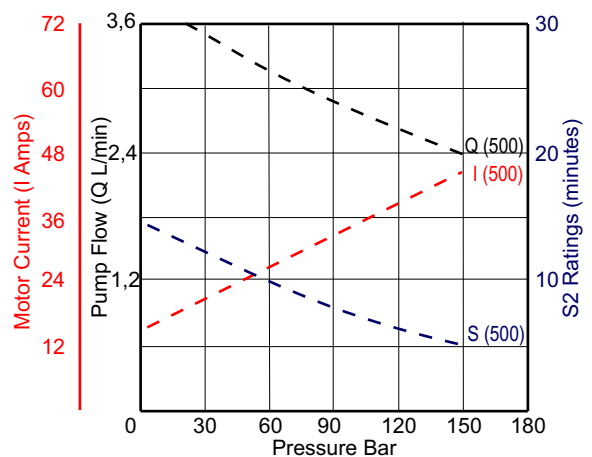
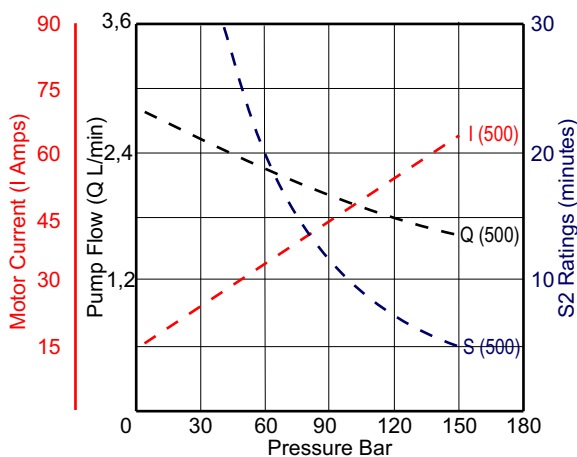
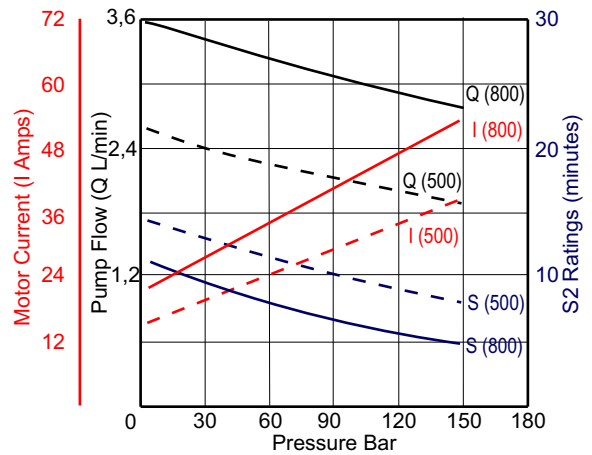
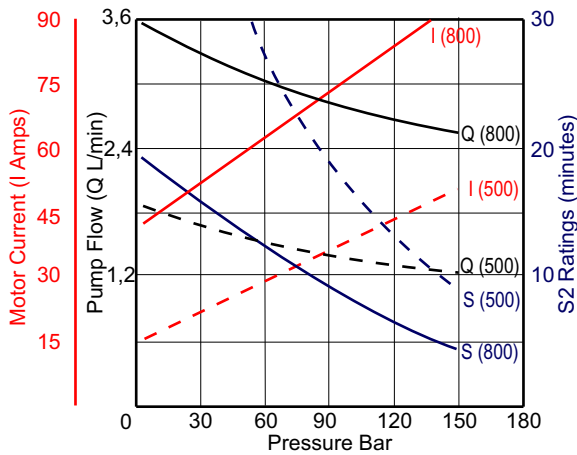
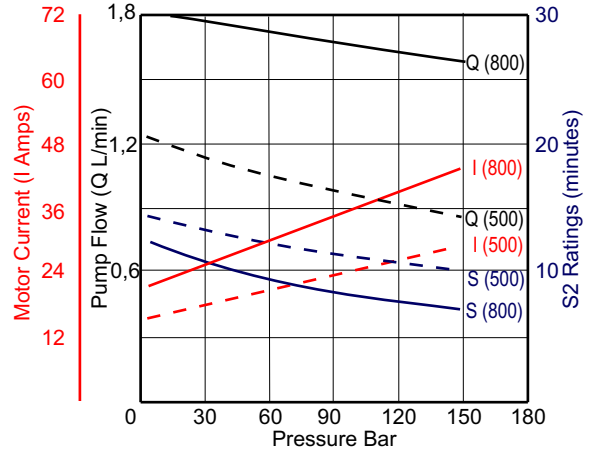

Reversible AUTOPACKS - TECHNICAL DATA

Hydraulic Fluid(recommended)

Mineral hydraulic oil (HM or HV)
 For normal ambient temp range (0°C-40°C)
 ISO VG22 to ISO VG46
 Working temp (ambient) -20°C - +40°C

Weight (app) kg

With 150/200W motor 2,8kg
Maximum Pressure (see performance curves)
 All pump sizes 180bar

Options Available

Reversing Start Switch
 Remote Start/Stop Switch Pendants
 Foot mounting bracket
 Circuit variations available eg. for single acting circuits, auxiliary connection ports etc. (min quantity may be required).

Installation, Operation, Commissioning

If mounting vertically, the tank must be uppermost.
 The 1L tank (code B10) must be horizontal
 Tanks must normally be vented to atmosphere. The volume is reduced if used unvented due to the need for air space.
 It can be very difficult to fill the tank through the body tapping due to air locks. Remove the tank for initial filling.

Priming. Reversible packs can appear not to work when first commissioned. Invariably they will need air bleeding from the pump suction valves. Loosen the lower side plugs while the pack is running until all the trapped air has bubbled out. This will not be needed again unless oil is lost from the pack.

Reversible Operation. The motor is polarity sensitive so it is only necessary to reverse the 2 connection leads to change direction. Use of the KSW**R01A Reversing Contactor simplifies wiring and ensures that the supply cannot short-circuit during changeover.

MAIN SPARES KITS

Pump Kit	KPF0**06A	** = pump code ref	Centre Plate Kit	KCAA3101B
Seal Kit	KSKA01A			
Motor Kit	KMD***01A	*** = motor code ref (eg R2J)	Foot Mtg Bracket	101876
			Reversing Switch	KSW**R01A (* ** = 12 or 24)
Tank Kit	KTA***01A	*** = tank code ref (eg E05)		

Reversible AUTOPACK - ORDERING CODES

500W & 800W DC Motors

R	2K	05	PRNS	NNN	XXX																																																																			
R Reversible	Motor	Pump Capacity	Circuit Elements	Tank	Special Code																																																																			
<table border="1" style="width: 100%; border-collapse: collapse;"> <tr><td>1</td><td>12V</td></tr> <tr><td>2</td><td>24V</td></tr> <tr><td>J</td><td>500W</td></tr> <tr><td>K</td><td>800W</td></tr> <tr><td>N N</td><td>No motor</td></tr> <tr><td>X X</td><td>Special</td></tr> </table>	1	12V	2	24V	J	500W	K	800W	N N	No motor	X X	Special	<table border="1" style="width: 100%; border-collapse: collapse;"> <tr><td>02</td><td>0,25 cc/rev</td></tr> <tr><td>05</td><td>0,50 cc/rev</td></tr> <tr><td>07</td><td>0,75 cc/rev</td></tr> <tr><td>XX</td><td>Special</td></tr> </table>	02	0,25 cc/rev	05	0,50 cc/rev	07	0,75 cc/rev	XX	Special	<table border="1" style="width: 100%; border-collapse: collapse;"> <tr><td>P</td><td></td><td>Pilot Check Valve</td></tr> <tr><td>R</td><td></td><td>Relief Valve</td></tr> <tr><td>M</td><td></td><td>Manual Release</td></tr> <tr><td>S</td><td></td><td>Standard Body</td></tr> <tr><td>X</td><td></td><td>Special</td></tr> <tr><td>N N N N</td><td></td><td>None Fitted</td></tr> </table>	P		Pilot Check Valve	R		Relief Valve	M		Manual Release	S		Standard Body	X		Special	N N N N		None Fitted	<table border="1" style="width: 100%; border-collapse: collapse;"> <tr><td>B</td><td></td><td>Side Filler</td></tr> <tr><td>C</td><td></td><td>Side Filler (tank) Not with 05</td></tr> <tr><td>E</td><td></td><td>End Filler</td></tr> <tr><td>P</td><td></td><td>Pressurised Not with 10</td></tr> <tr><td>S</td><td></td><td>Without Filler</td></tr> <tr><td>0 2</td><td></td><td>0,2L capacity plastic</td></tr> <tr><td>0 5</td><td></td><td>0,5L capacity steel</td></tr> <tr><td>0 7</td><td></td><td>0,75L capacity plastic</td></tr> <tr><td>B 1 0</td><td></td><td>1,0L capacity plastic</td></tr> <tr><td>X X</td><td></td><td>Special</td></tr> </table>	B		Side Filler	C		Side Filler (tank) Not with 05	E		End Filler	P		Pressurised Not with 10	S		Without Filler	0 2		0,2L capacity plastic	0 5		0,5L capacity steel	0 7		0,75L capacity plastic	B 1 0		1,0L capacity plastic	X X		Special	<div style="border: 1px solid black; padding: 5px; width: fit-content; margin: auto;"> Allocated by manufacturer for all custom and non-standard assemblies. </div>
1	12V																																																																							
2	24V																																																																							
J	500W																																																																							
K	800W																																																																							
N N	No motor																																																																							
X X	Special																																																																							
02	0,25 cc/rev																																																																							
05	0,50 cc/rev																																																																							
07	0,75 cc/rev																																																																							
XX	Special																																																																							
P		Pilot Check Valve																																																																						
R		Relief Valve																																																																						
M		Manual Release																																																																						
S		Standard Body																																																																						
X		Special																																																																						
N N N N		None Fitted																																																																						
B		Side Filler																																																																						
C		Side Filler (tank) Not with 05																																																																						
E		End Filler																																																																						
P		Pressurised Not with 10																																																																						
S		Without Filler																																																																						
0 2		0,2L capacity plastic																																																																						
0 5		0,5L capacity steel																																																																						
0 7		0,75L capacity plastic																																																																						
B 1 0		1,0L capacity plastic																																																																						
X X		Special																																																																						

NOTE. 12V 500W (R1J) motor is the same part as 24V 800W (R2K) motor.

The products are subject to development and the manufacturer reserves the right to change the specifications without notice

Items THUS are non-preferred.