

'G' Series PUMP-MOTOR UNITS

**Versatile range of 12V & 24V dc
Pump-Motor Units for mobile applications.
Flows to 20l/min
Pressures to 300bar
Motors 1,6kW to 3kW (nominal)**

FEATURES

Pressure balanced gear pump
in common with Mk3D & "G" Packs.
Quiet operation with long life
Easy to install with integral mounting points
Precision "quiet" relief valve
Wide range of options
Global support & servicing

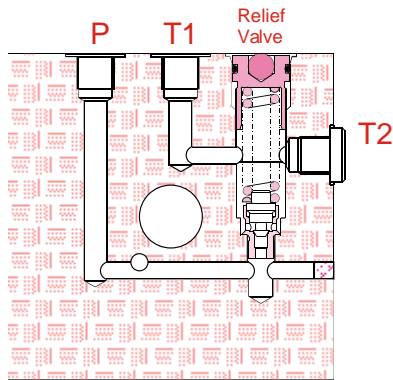

Sectional View

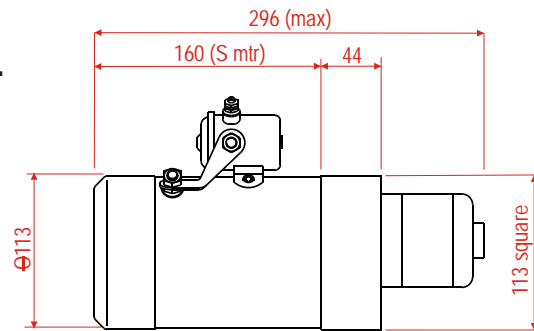
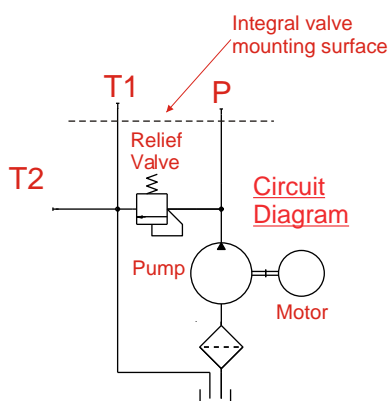

Typical PMU with 4.5" (113mm) S Motor

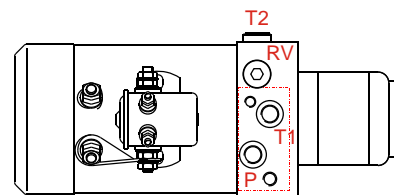

Plan View showing connection face

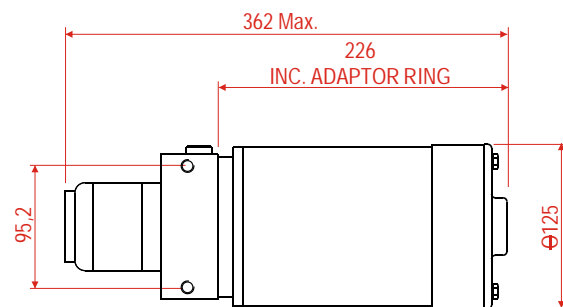

PMU with 5" (125mm) L motor (underside)
showing 2 x M10 mounting holes

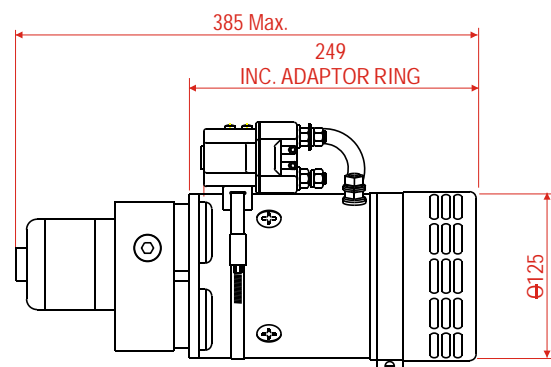

PMU with 5" (125mm) F motor
showing HD Start Switch

PERFORMANCE DATA 'G' Series PUMP-MOTOR UNITS

MOTOR TYPE S (Series Wound, Ø113mm)

Nominal performance of pack combinations at constant voltage and at nominal 20^o-25^o C with ISO VG22 oil.

12V Motor

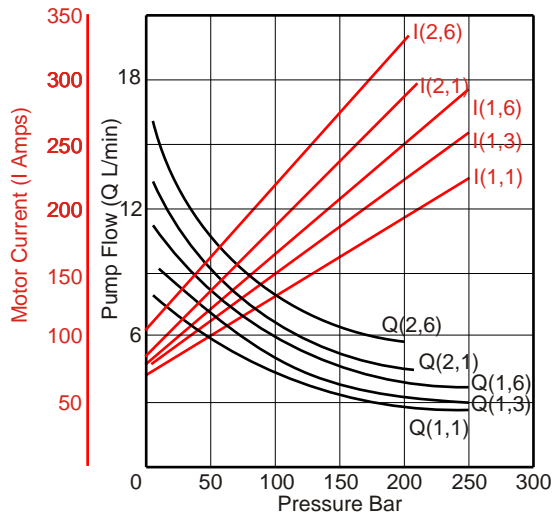

For Pump Capacities:
 1,1cc/rev
 1,3cc/rev
 1,6cc/rev
 2,1cc/rev
 2,6cc/rev

24V Motor

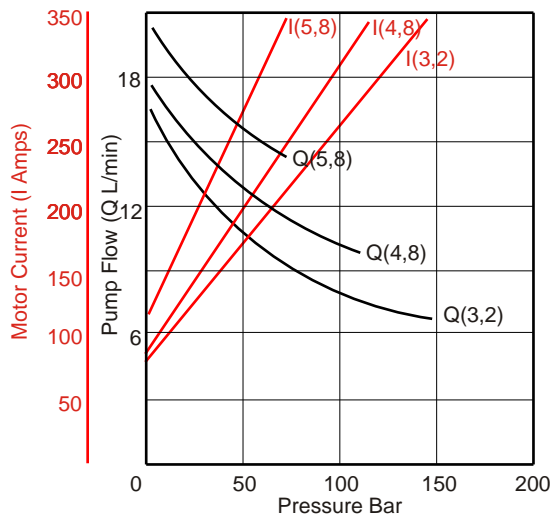
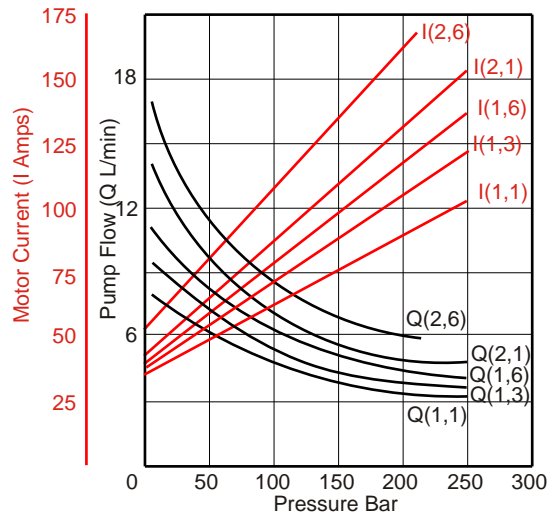

For Pump Capacities:
 3,2cc/rev
 4,8cc/rev
 5,8cc/rev

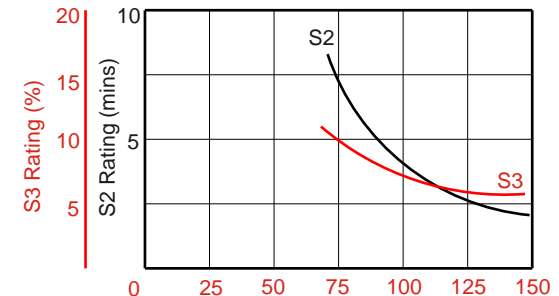
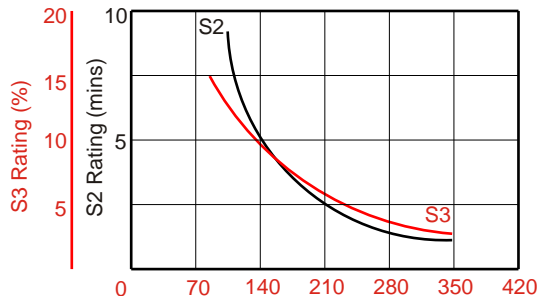
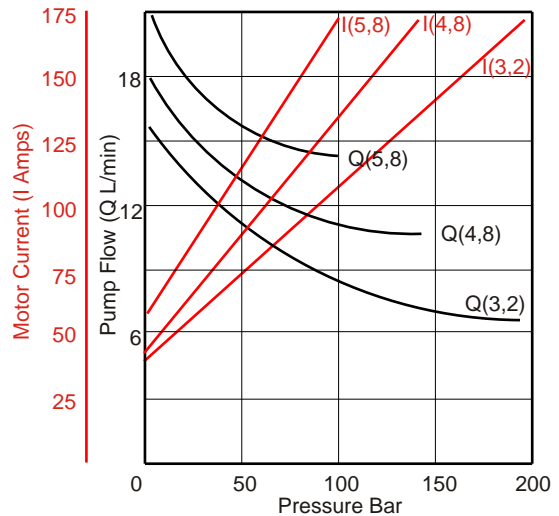

PERFORMANCE DATA 'G' Series PUMP-MOTOR UNITS

MOTOR TYPES L & F (Long Rated/Fan Cooled $\varnothing 126\text{mm}$)

Nominal performance of pack combinations at constant voltage
and at nominal 20^o-25^o C with ISO VG22 oil.

24V 'L' Motor

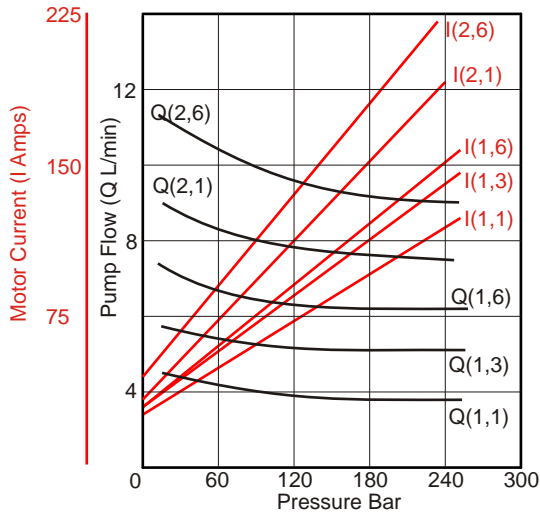

For Pump Capacities:
1,1cc/rev
1,3cc/rev
1,6cc/rev
2,1cc/rev
2,6cc/rev

24V 'F' Motor

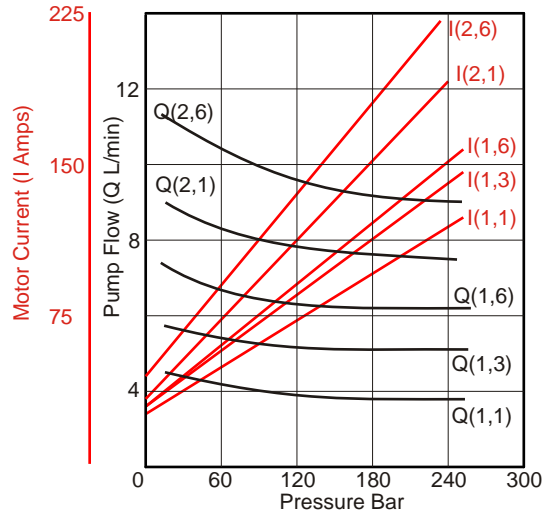

For Pump Capacities:
3,2cc/rev
4,8cc/rev
5,8cc/rev

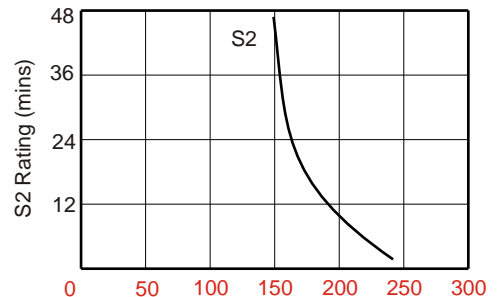
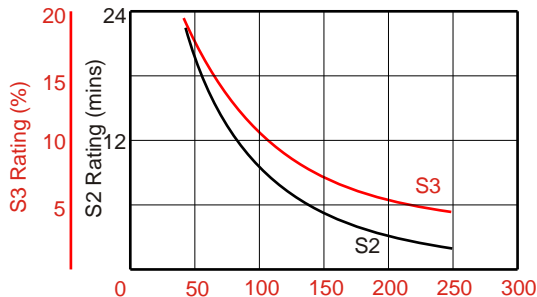
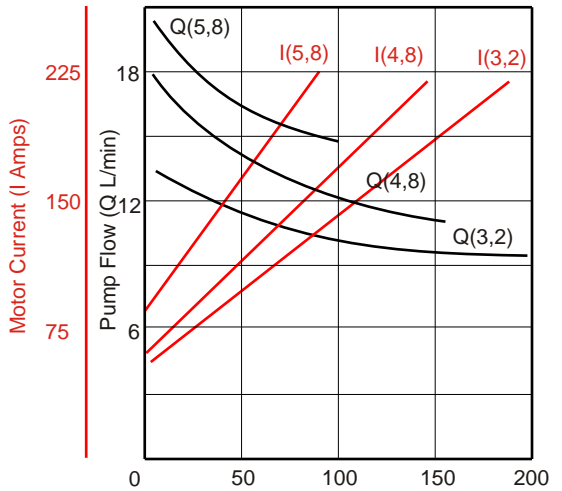
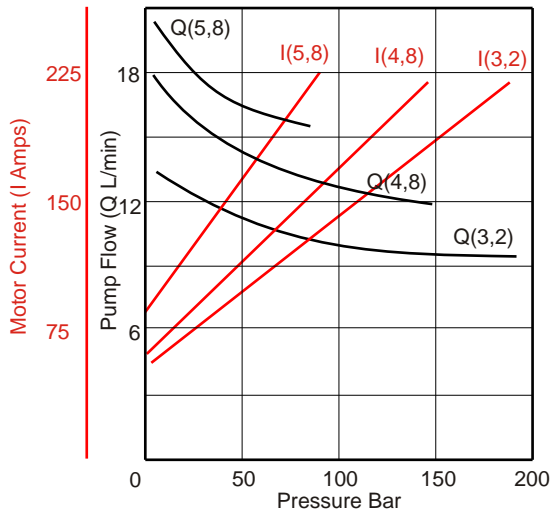

'G' Series PUMP-MOTOR UNITS - TECHNICAL DATA

Hydraulic Fluid(recommended)

Mineral hydraulic oil (HM or HV)
For normal ambient temp range (0°C-40°C)
ISO VG22 to ISO VG46

Working temp (ambient) -20°C - +40°C

Weight (app) kg

'S' Motor	'L' Motor	'F' Motor
10,5	14,5	12,5

Maximum Pressures (see performance curves)

0,8cc	200bar
1,1 to 2,6cc	275bar
3,2cc	240bar
4,8 5,8cc	200bar

Options Available

Heavy Duty Start Switch
Remote Start/Stop Switch Pendants

Manifolds & Control valves Cetop03
Manifolds & Control valves Series35
Special Valve Blocks
Weatherproof Box and Motor Cover

Start Switches.

"S" motors are normally supplied fitted with standard start switches. Heavy Duty Start Switches are optional on L & F motors.

MAIN SPARES KITS

Pump Kit	KPG**01A	** = pump code ref	Centre Plate Kit	KCPMG201A
Seal Kit	KSKPMG01A			
Motor Kit	KMD***01A	*** = motor code ref (eg 2RS)		
Starter Kit	KSW**S01A	** = 12 or 24 (for S motors only)		
	KSW**H01A	** = 12 or 24 (L or F motors)		

'G' Series PUMP-MOTOR UNITS - ORDERING CODES

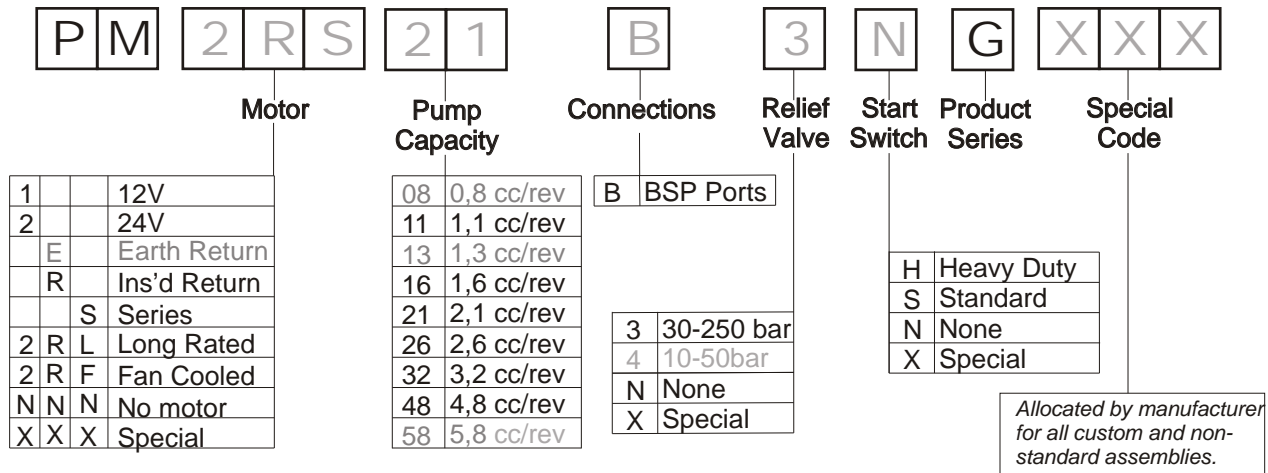

Items **THUS** are non-preferred.
Earth Return applies to 12V 'S' motors only
12V L motors are on special order only.
F motors are 24V only.

Standard (S) start switches are normally fitted to type S motors.
Heavy Duty start switches are optional on type L & F motors.

The products are subject to development and the manufacturer reserves the right to change the specifications without notice