

OMEW Standard
and with Low
Speed Option

Orbital Motors

Technical
Information

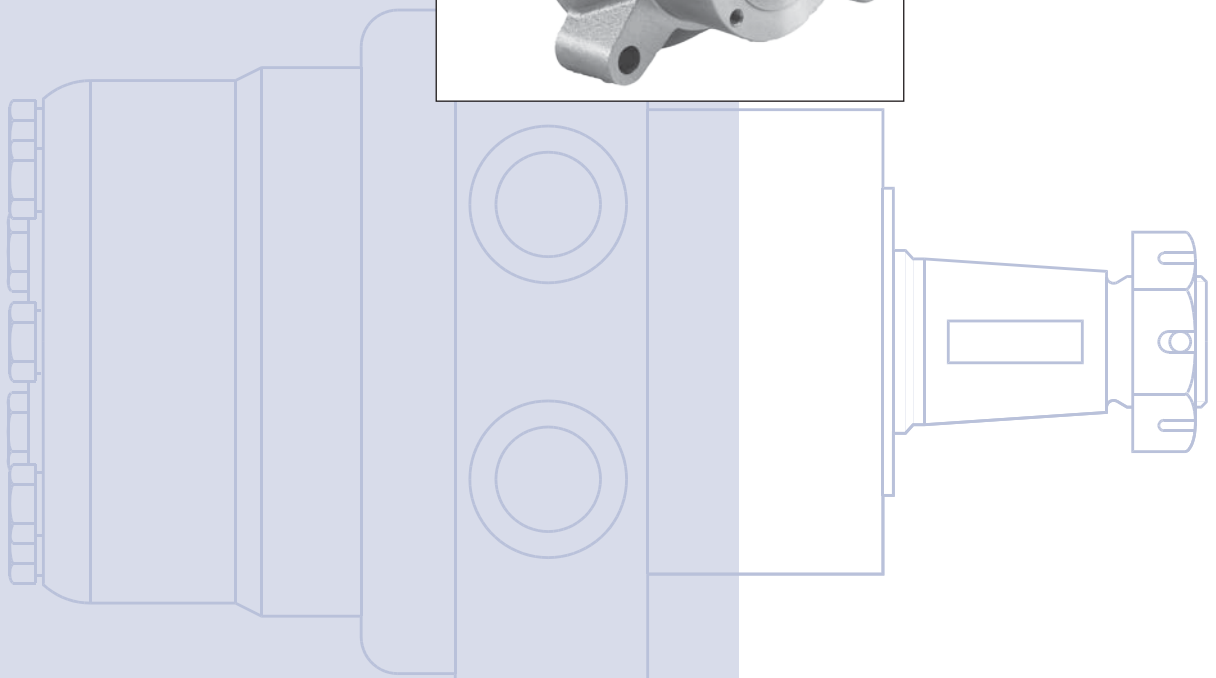
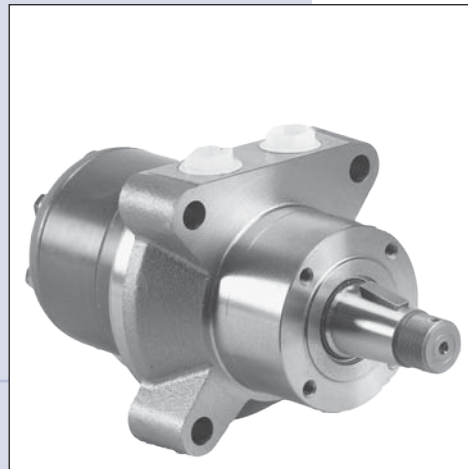
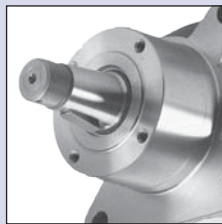
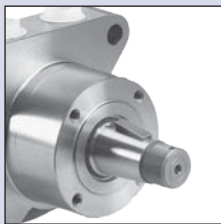

Revision History

Table of Revisions

Date	Page	Changed	Rev
Jan 2009	Many	major change	BA
Mar 2010	16	Japan location	BB

Contents

Contents 2

Introduction 3

 Versions 4

 Code Numbers 5

Technical data 6

 Technical data for OMEW 6

 Max. permissible shaft seal pressure 7

 Pressure drop in motor 8

 Direction of shaft rotation 8

 Permissible shaft loads for OMEW 9

 Shaft version 10

 Port thread version 10

Dimensions 11

© 2010 Sauer-Danfoss. All rights reserved.

Sauer-Danfoss accepts no responsibility for possible errors in catalogs, brochures and other printed material. Sauer-Danfoss reserves the right to alter its products without prior notice. This also applies to products already ordered provided that such alterations can be made without affecting agreed specifications. All trademarks in this material are properties of their respective owners. Sauer-Danfoss, the Sauer-Danfoss logotype, the Sauer-Danfoss S-icon, PLUS+1™, what really matters is inside® and Know-How in Motion™ are trademarks of the Sauer-Danfoss Group.

Front cover illustrations: F300722, drawing: 151-2024

Introduction

Sauer-Danfoss is offering the OMEW motor in two different versions. Both versions are designed mainly for propel applications, but they are optimize for different conditions.

A. OMEW standard version.

The advantage by this motor lies in the high speed area. When the flow exceeds 40 l/min this motor is to prefer due to a lower pressure drop.

B. OMEW with low speed option.

The advantage by this motor lies in the Low speed area. This motor has higher efficiency at low speed / medium pressure. When the flow is below 40 l/min this motor is to prefer. This motor also has the Brake nose which makes it possible to add a drum brake to the motor.

Although the OMEW transmission motor was mainly designed for vehicles such as

- Walk-behind mowers
- Ride on mowers
- Scissor lifts
- Sweepers
- Road rollers

It is also suitable for a wide range of other applications that require a motor that is both compact and gives high efficiency.

Characteristic features that distinguish the OMEW motor are

- Compact design
- Low weight
- High total efficiency
- High starting torque
- Smooth low speed performance
- Larger bearing capacity
- High pressure shaft seal
- No drain line

Versions

Mounting flange	Shaft	Port size	Pilot	European version	US version	Clockwise shaft rotation (CW version) ¹⁾	Counter clockwise shaft rotation (CCW version) ¹⁾	Standard version	Low speed version	Painted Black	Main type designation
Wheel, Standard	Tapered 1 1/4 in	7/8 - 14 UNF	3.25 in		X	X		X		Yes	OMEW
		7/8 - 14 UNF	3.25 in		X		X	X		Yes	OMEW
	Tapered 35 mm	G 1/2	82.5 mm	X		X		X		No	OMEW
		G 1/2	82.5 mm	X			X	X		No	OMEW
Wheel, Low Speed	Tapered 1 1/4 in	7/8 - 14 UNF	3.50 in		X	X			X	Yes	OMEW
		7/8 - 14 UNF	3.50 in		X		X		X	Yes	OMEW

1) Direction of rotation

In applications that mainly involves operation in one direction, we recommend a corresponding motor with either CW- or CCW-rotation.

High pressure seals

Since all OMEW motors are fitted with a high-pressure shaft seal, there is no need for a drain line.

Code Numbers

Code Numbers	Displacement								Technical Data - Page	Dimensions - Page
	100	125	160	200	250	315	345	400		
151H	3108	3109	3110	3111	3112	3113	3114	3115	6	12
151H	3118	3119	3120	3121	3122	3123	3124	3125	6	12
151H	2002	2003	2004	2005	2006	2007			6	11
151H	2011	2012	2013	2014	2015	2016			6	11
151H	3080	3081	3082	3083	3084	3085	3086	3087	6	13
151H	3090	3091	3092	3093	3094	3095	3096	3097	6	13

Ordering

Add the four digit prefix "151H" to the four digit numbers from the chart for complete code number.

Example:

151H3084 for an OMEW 250 with 1 1/4 in tapered shaft, port size 7/8 - 14 UNF and clockwise rotation (CW).

Note: Orders will not be accepted without the four digit prefix.

Technical Data for OMEW with 35 mm and 1 1/4 in Tapered Shaft

Type		OMEW	OMEW	OMEW	OMEW	OMEW	OMEW	OMEW	OMEW	
Motor Size		100	125	160	200	250	315	345	400	
Geometric displacement	cm ³ [in ³]	99.8 [6.11]	124.1 [7.60]	155.4 [9.51]	198.2 [12.13]	248.1 [15.18]	310.1 [18.98]	341.8 [20.86]	390.7 [23.83]	
Max speed	min ⁻¹ [rpm]	cont.	600	475	375	300	240	190	175	150
		int. ¹⁾	750	695	470	375	300	240	220	190
Max torque	Nm [lbf·in]	cont.	250 [2210]	320 [2830]	410 [3630]	400 [3540]	470 [4160]	550 [4868]	610 [5400]	700 [6195]
		int. ¹⁾	270 [2390]	340 [3010]	430 [3810]	570 [5045]	710 [6284]	850 [7523]	860 [7612]	870 [7700]
Max output	kW [hp]	cont.	12 [16.1]	12 [16.1]	12 [16.1]	11 [14.75]	10 [13.41]	9 [12.07]	9 [12.07]	9 [12.07]
		int. ¹⁾	15 [20.1]	15 [20.1]	15 [20.1]	16 [21.5]	16 [21.5]	15 [20.1]	14 [18.8]	12 [16.1]
Max pressure drop	bar [psi]	cont.	200 [2900]	200 [2900]	200 [2900]	150 [2175]	140 [2030]	130 [1885]	130 [1885]	130 [1885]
		int. ¹⁾	210 [3045]	210 [3045]	210 [3045]	210 [3045]	210 [3045]	200 [2900]	185 [2683]	160 [2320]
Max oil flow	l/min [USgal/min]	cont.	60 [15.9]	60 [15.9]	60 [15.9]	60 [15.9]	60 [15.9]	60 [15.9]	60 [15.9]	60 [15.9]
		int. ¹⁾	75 [19.8]	75 [19.8]	75 [19.8]	75 [19.8]	75 [19.8]	75 [19.8]	75 [19.8]	75 [19.8]
Max starting pressure with unloaded shaft	bar [psi]	10 [145]	7 [100]	7 [100]	7 [100]	7 [100]	7 [100]	7 [100]	7 [100]	
Min starting torque	at max press drop cont.	230 [2040]	290 [2570]	360 [3190]	330 [2920]	390 [3451]	460 [4071]	500 [4425]	580 [5133]	
	at max press drop int. ¹⁾	240 [2120]	300 [2660]	380 [3360]	470 [4160]	580 [5133]	700 [6195]	710 [6284]	710 [6284]	

Type			Max Inlet Pressure	Max Return Pressure
OMEW 100 - 400	bar	cont.	200	200
	[psi]		[2900]	[2900]
	bar	int. ¹⁾	210	210
	[psi]		[3050]	[3050]
bar	peak ²⁾	225	225	
[psi]		[3260]	[3260]	

¹⁾ Intermittent operation: the permissible values may occur for max. 10% of every minute.

²⁾ Peak load: the permissible values may occur for max. 1% of every minute.

Max Permissible Shaft Seal Pressure

OMEW with high pressure shaft seal

CW version (clockwise rotation)

- 1) By clockwise rotation:
The shaft seal pressure equals the return pressure.
- 2) By counter clockwise rotation:
The shaft seal pressure equals the input pressure

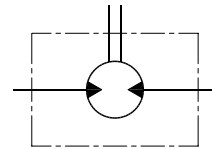

151-1743.10

CCW version (counter clockwise rotation)

- 1) By counter clockwise rotation:
The shaft seal pressure equals the return pressure.
- 2) By clockwise rotation:
The shaft seal pressure equals the input pressure

Max permissible shaft seal pressure

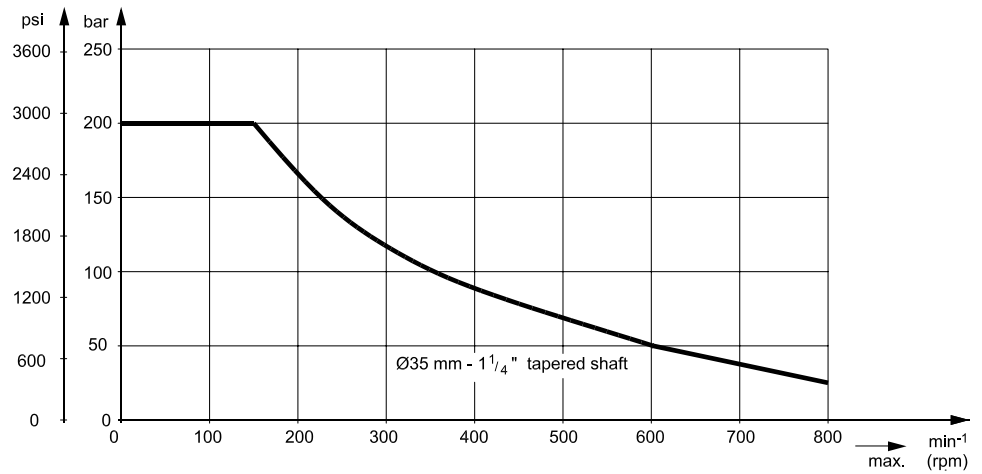

151-1861.10

Pressure Drop in Motor

Standard

A: OMEW 100 - 400

Low Speed

A: OMEW 100 - 160

B: OMEW 200 - 400

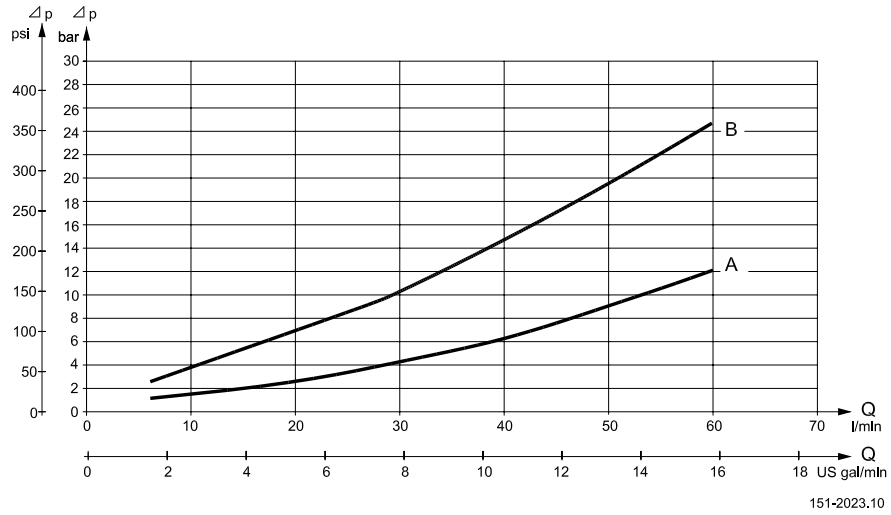

151-2023.10

The curve applies to an unloaded motor shaft and an oil viscosity of 35 mm²/s [165 SUS]

Direction of Shaft Rotation

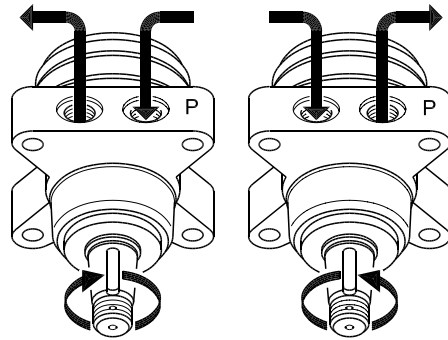

CW - motor

151-1655.10

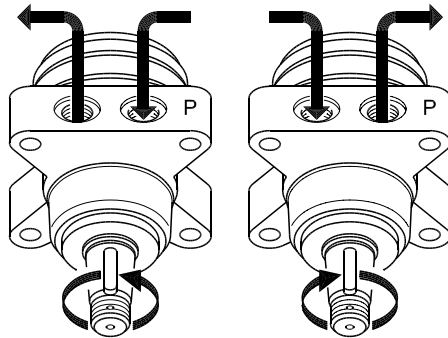

CCW - motor

151-1655.10

**Permissible Shaft Loads
for OMEW**

As the OMEW output shaft is embedded in needle bearings and the mounting flange is recessed it is possible to fit a wheel hub direct onto the shaft so that the radial load acts midway between the needle bearings.

Based upon the requested max. speed and the point of action of the radial load the permissible shaft load can be read from the curved shown below.

Curve A shows the max. radial load. If the radial load exceeds these values there is a potential risk of breakdown.

The other curves apply to a B10 bearing life of 2000 hours at the indicated speed when applying a hydraulic mineral oil with an adequate content of anti-wear additives.

The lifetime can also be calculated by means of the "Bearing dimensions" instructions in the technical information »General« **520L0232**.

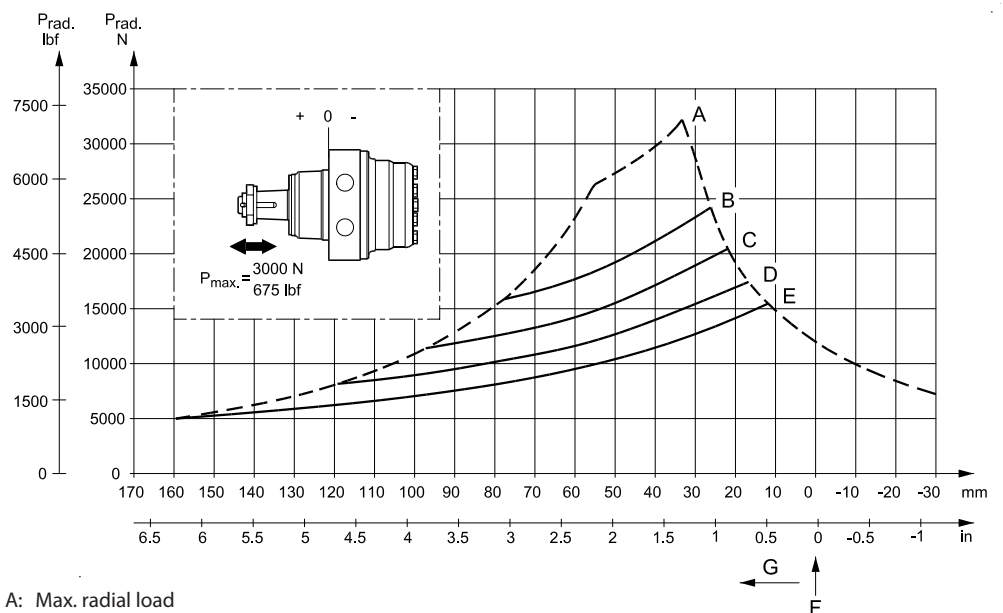

- A: Max. radial load
- B: $n = 50 \text{ min}^{-1}$ (rpm)
- C: $n = 100 \text{ min}^{-1}$ (rpm)
- D: $n = 200 \text{ min}^{-1}$ (rpm)
- E: $n = 400 \text{ min}^{-1}$ (rpm)
- F: Front flange
- G: Direction toward shaft

151-1725.10

Shaft Version

- I: Tapered shaft 35 mm
- N: DIN 937
- NV 41
- Tightening torque:
200 ± 10 N·m [1770 ± 85 lbf·in]
- M: Taper 1:10
- P: Parallel key
B6 · 6 · 20
DIN 6885

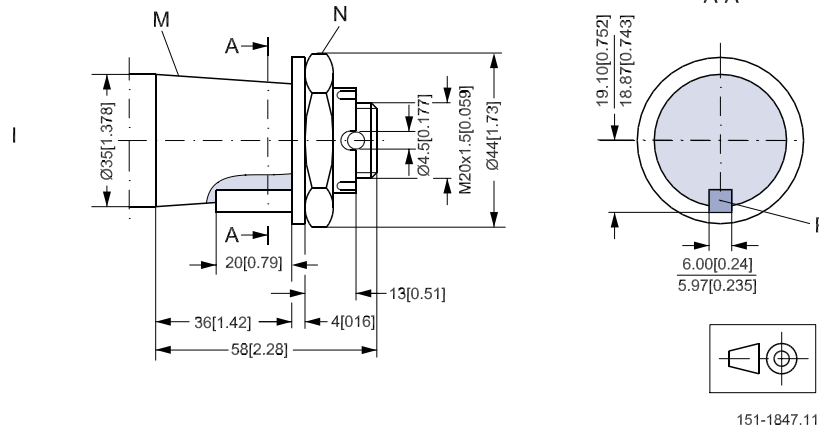

Shaft Version

- Tapered shaft 1 1/4 in
- B: Cone 1:8
- SAE J501
- C: 1 - 20 UNEF
- Across flats 1 7/16
- Tightening torque:
400 ± 10 N·m [3540 ± 85 lbf·in]
- D: Woodruff key
5/16 × 1
SAE J502 1a

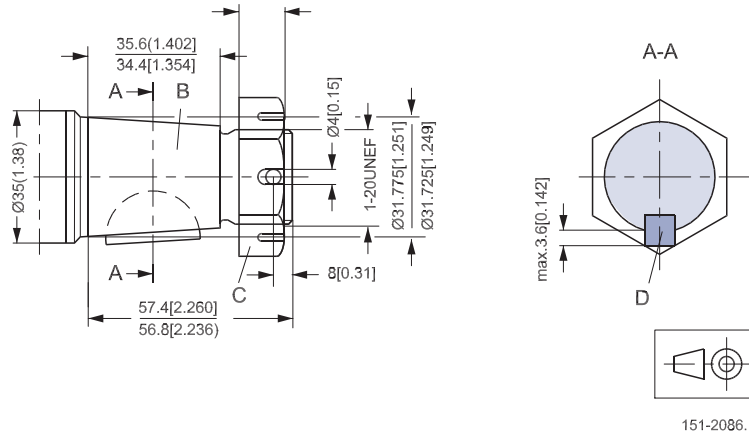

Port Thread Version

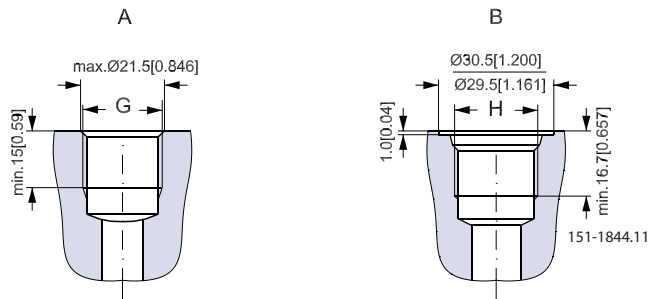

A: G main ports
G: ISO 228/1-G1/2

B: UNF main ports
H: 7/8-14 UNF
O-ring boss port

Dimensions

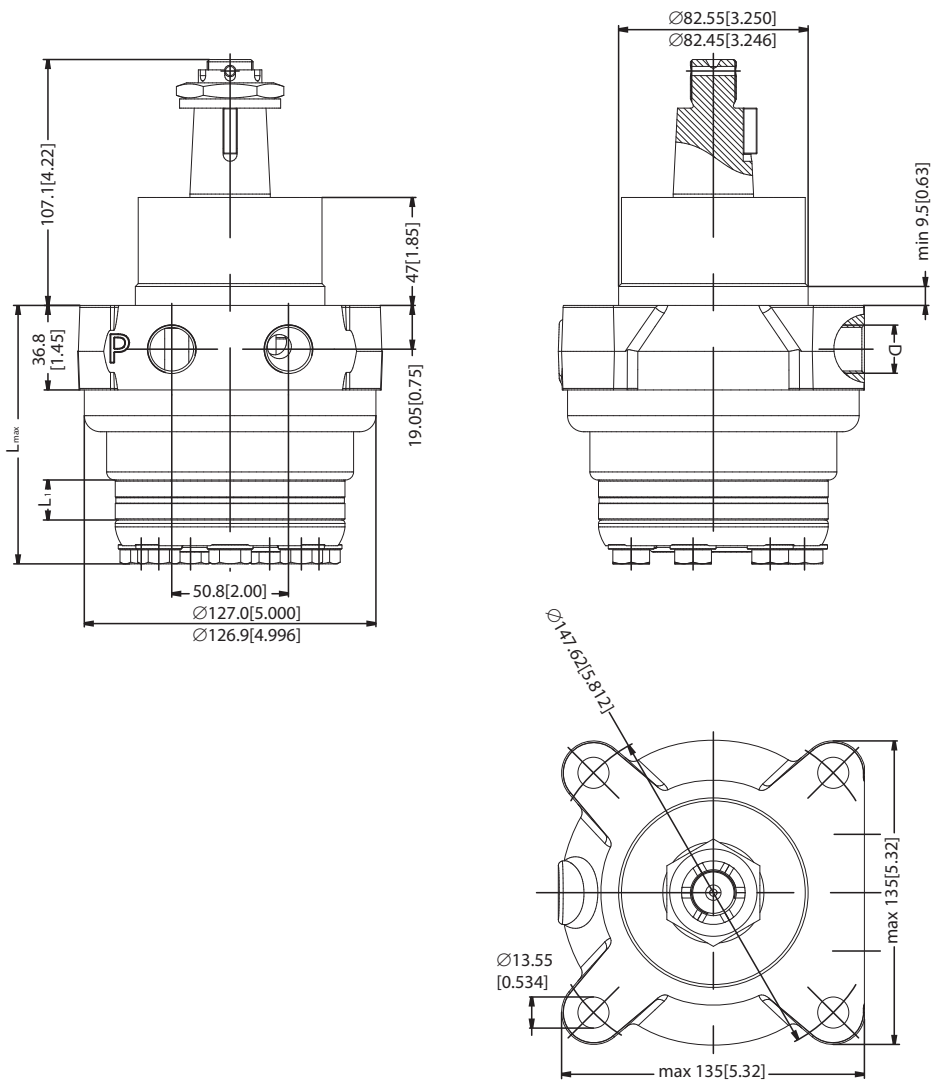

P301 103

Type	L _{max} mm [in]	L ₁ mm [in]	Weight kg [lb]
OMEW 100	112.0 [4.41]	14.0 [0.55]	9.3 [20.5]
OMEW 125	115.4 [4.54]	17.4 [0.69]	9.5 [20.9]
OMEW 160	119.8 [4.72]	21.8 [0.86]	9.8 [21.6]
OMEW 200	125.8 [4.95]	27.8 [1.09]	10.3 [22.7]
OMEW 250	132.8 [5.23]	34.8 [1.37]	10.8 [23.8]
OMEW 315	137.4 [5.41]	43.5 [1.71]	11.3 [24.9]

D: G 1/2, 15 mm [0.59] deep

Dimensions

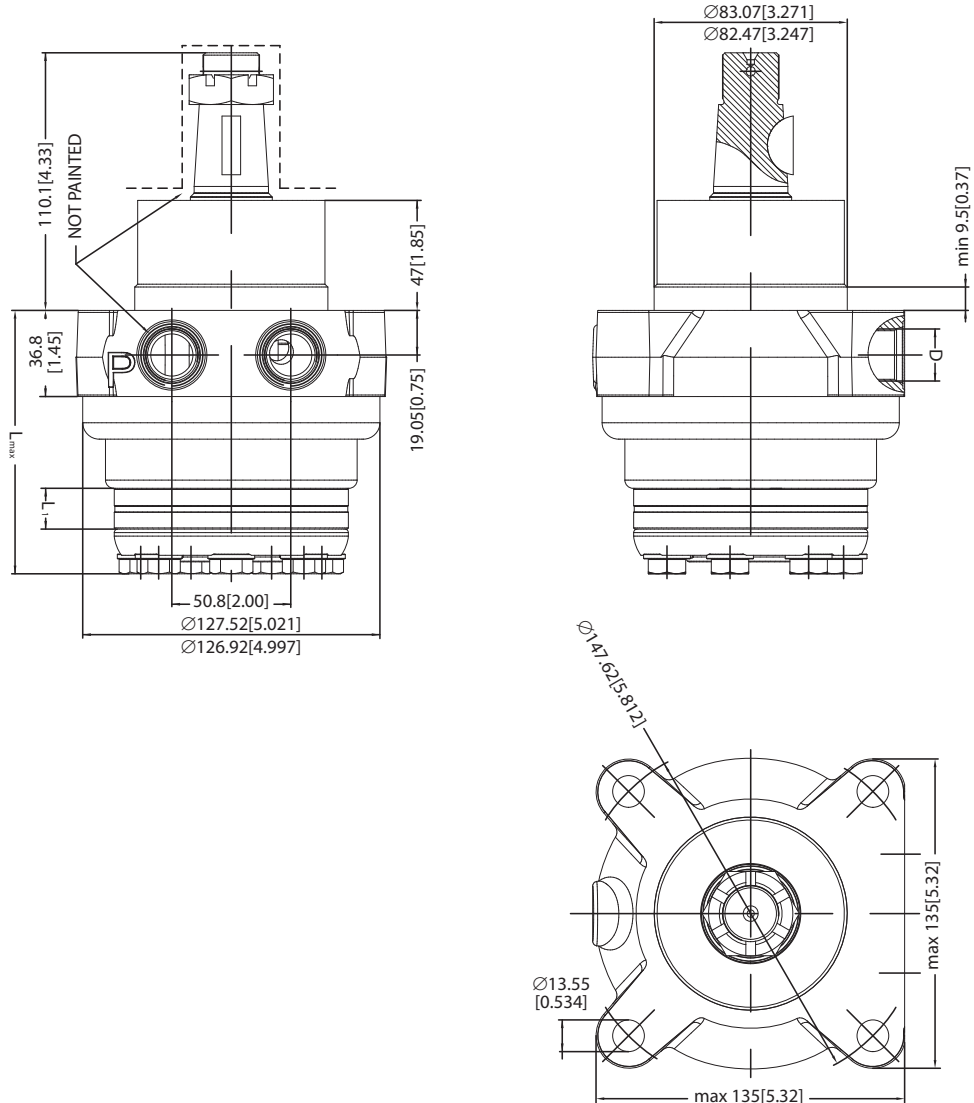

P301 101

Type	L _{max} mm [in]	L ₁ mm [in]	Weight kg [lb]
OMEW 100	112.0 [4.41]	14.0 [0.55]	9.3 [20.5]
OMEW 125	115.4 [4.54]	17.4 [0.69]	9.5 [20.9]
OMEW 160	119.8 [4.72]	21.8 [0.86]	9.8 [21.6]
OMEW 200	125.8 [4.95]	27.8 [1.09]	10.3 [22.7]
OMEW 250	132.8 [5.23]	34.8 [1.37]	10.8 [23.8]
OMEW 315	141.5 [5.57]	43.5 [1.71]	11.3 [24.9]
OMEW 345	145.9 [5.74]	48.0 [1.89]	11.6 [25.6]
OMEW 400	152.8 [6.02]	54.9 [2.16]	12.0 [26.5]

D: 7/8 - 14 UNF, 16.7 [0.66] deep

--- Not painted
 Please note:
 The stated dimension is with paint

Dimensions

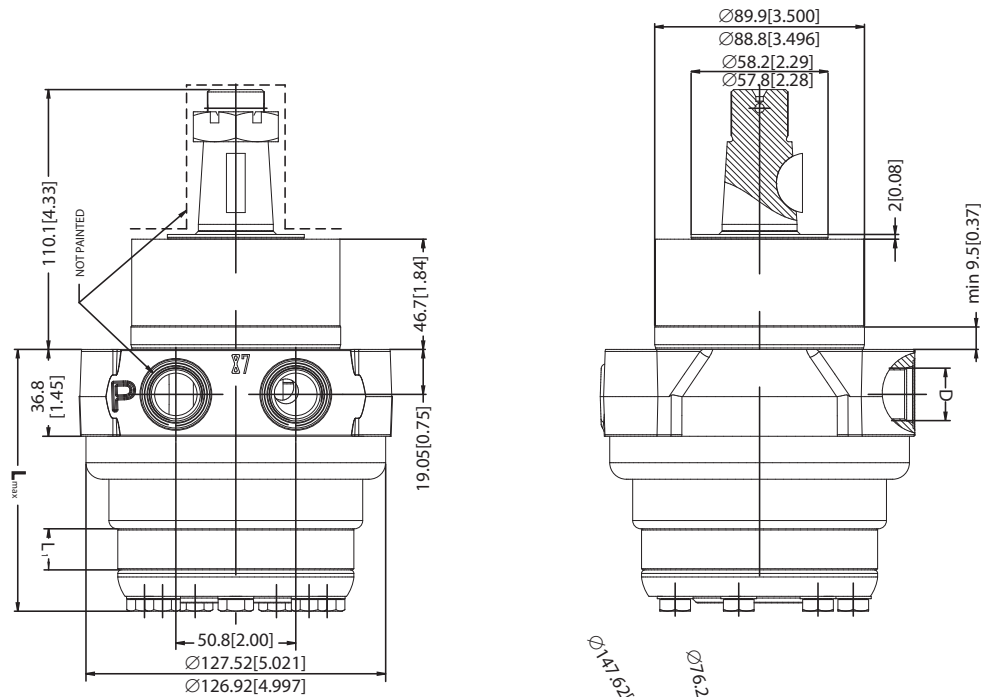

Type	L _{max} mm [in]	L ₁ mm [in]	Weight kg [lb]
OMEW 100	110.1 [4.33]	14.0 [0.55]	9.3 [20.5]
OMEW 125	113.5 [4.47]	17.4 [0.69]	9.5 [20.9]
OMEW 160	117.9 [4.64]	21.8 [0.86]	9.8 [21.6]
OMEW 200	123.9 [4.88]	27.8 [1.09]	10.3 [22.7]
OMEW 250	130.9 [5.15]	34.8 [1.37]	10.8 [23.8]
OMEW 315	139.6 [5.50]	43.5 [1.71]	11.3 [24.9]
OMEW 345	144.0 [5.67]	47.9 [1.89]	11.6 [25.6]
OMEW 400	150.9 [5.94]	54.8 [2.16]	12.0 [26.5]

D: 7/8 - 14 UNF, 16.7 [0.66] deep
E: Thread for external brake
4 x 5/16-18 UNC, min 20 [0.79] deep

--- Not painted
Please note:
The stated dimension is with paint

