

Versions

Mounting angle	Spigot diameter (front / rear end)	Bolt circle diameter (BC)	Shaft	Port size	European version	US version	Side port version	End port version	Flange port version	Standard shaft seal	High pressure shaft seal	Drain connection	Check valve	Main type designation	
2 hole oval flange (A2-flange)	Ø 82.5 mm [3.25 in]	Ø 106.4 mm [4.20 in]	Cyl. 25 mm	G ½	I		I				I	No	No	OMR	
				G ½	I		I			I	Yes	Yes	OMR		
				G ½	I			I		I	Yes	Yes	OMR		
			Cyl. 1 inch	G ½	I		I				I	No	No	OMR	
				G ½	I		I				I	Yes	Yes	OMR	
				7/8-14 UNF		I	I				I	Yes	Yes	OMR	
			Splined 1 inch	G ½	I		I					I	No	No	OMR
				G ½	I		I					I	Yes	Yes	OMR
				7/8-14 UNF		I	I				I	Yes	Yes	OMR	
			Cyl. 32 mm	G ½	I		I				I		Yes	Yes	OMR
Tap. 28.5 mm	G ½	I		I				I		Yes	Yes	OMR			
4 hole oval flange (A4-flange)	Ø 82.5 mm [3.25 in]	Ø 106.4 mm [4.20 in]	Cyl. 25 mm	G ½	I		I			I		Yes	Yes	OMR	
			Cyl. 32 mm	G ½	I		I			I		Yes	Yes	OMR	
			Cyl. 1¼ in	7/8-14 UNF		I	I			I		Yes	Yes	OMR	
Square flange (C-flange)	Ø 44.4 mm [1.75 in]	Ø 82.5 mm [3.25 in]	Cyl. 25 mm	G ½	I			I		I		Yes	Yes	OMR	
			Cyl. 1 in	7/8-14 UNF		I	I			I		Yes	Yes	OMR	

OMR motors with corrosion resistant parts

2 hole oval flange (A2-flange)	Ø 82.5 mm [3.25 in]	Ø 106.4 mm [4.20 in]	Cyl. 25 mm	G ½	I		I			I		Yes	Yes	OMR C
--------------------------------	---------------------	----------------------	------------	-----	---	--	---	--	--	---	--	-----	-----	-------

OMR motors with needle bearings

2 hole oval flange (A2-flange)	Ø 82.5 mm [3.25 in]	Ø 106.4 mm [4.20 in]	Cyl. 25 mm	G ½	I		I			I		Yes	Yes	OMR N
Wheel	Ø 82.5 mm [3.25 in]	Ø 147.6 mm [5.81 in]	Tap. 35 mm	G ½	I				I	I		Yes	Yes	OMRW N
			Tap. 1¼ in	7/8-14 UNF		I			I	I		Yes	Yes	OMRW N

OMR motors with integrated brake

2 hole oval flange (A2-flange)	Ø 82.5 mm [3.25 in]	Ø 106.4 mm [4.20 in]	Cyl. 25 mm	G ½	I		I			I		Yes	Yes	OMR F
--------------------------------	---------------------	----------------------	------------	-----	---	--	---	--	--	---	--	-----	-----	-------

OMR motors with integrated brake and needle bearings

2 hole oval flange (A2-flange)	Ø 82.5 mm [3.25 in]	Ø 106.4 mm [4.20 in]	Cyl. 1 in	7/8-14 UNF		I	I			I		Yes	Yes	OMR NF
Wheel	Ø 82.5 mm [3.25 in]	Ø 147.6 mm [5.81 in]	Tap. 35 mm	G ½	I				I	I		Yes	Yes	OMRW NF

Functions diagram - see page: →

Features available (options) :

Low leakage (low speed valve)      Reverse rotation  
Speed sensor      Painted  
Viton shaft seal

Code Numbers

Code numbers	Displacement [cm <sup>3</sup> ]									Technical data - Page	Dimensions - Page
	50	80	100	125	160	200	250	315	375		
151-	0410	0411	0412	0413	0414	0415	0416	0417	0418	42	61
151-	0710	0711	0712	0713	0714	0715	0716	0717	0718	42	62
151-	6190	6191	6192	6193	6194	6195	6196	6197	6198	42	64
151-	0400	0401	0402	0403	0404	0405	0406	0407	0408	42	61
151-	0700	0701	0702	0703	0704	0705	0706	0707	0708	42	62
151-	7240	7241	7242	7243	7244	7245	7246	7247	7248	42	65
151-	0420	0421	0422	0423	0424	0425	0426	0427	0428	43	61
151-	0720	0721	0722	0723	0724	0725	0726	0727	0728	43	62
151-	7250	7251	7252	7253	7254	7255	7256	7257	7258	43	65
151-	0248	0242	0243	0208	0244	0245	0247	0246	6294	44	63
151-	0265	0266	0267	6295	0268	0269	0271	0270	6296	43	63
151-	6010	6011	6012	6013	6014	6015	6016	6017	6018	42	66
151-	6000	6001	6002	6003	6004	6005	6006	6007	6008	44	66
151-	6110	6111	6112	6113	6114	6115	6116	6117	6118	44	67
151-	6210	6211	6212	6213	6214	6215	6216	6217	6218	42	68
151-	7260	7261	7262	7263	7264	7265	7266	7267	7269	42	69
<b>OMR motors with corrosion resistant parts</b>											
151-	1231	1232	1233	1238	1234	1235	1236	1237	1243	42	63
<b>OMR motors with needle bearings</b>											
151-	6380	6381	-	6383	6384	6385	6386	6387	6388	42	63
151-	6300	6301	6302	6303	6304	6305	6306	6307	6308	44	70
151-	6430	6431	6432	6433	6434	6435	6436	6437	6438	44	71
<b>OMR motors with integrated brake</b>											
151-	-	6461	6462	6463	6464	6465	6466	6467	6468	42	72
<b>OMR motors with integrated brake and needle bearings</b>											
151-	-	6471	6472	6473	6474	6475	6476	6477	6478	42	73
151-	-	-	6442	6443	6444	6445	-	-	-	44	74
→	51	51	52	52	53	53	54	54	55		

Ordering

Add the four digit prefix "151-" to the four digit numbers from the chart for complete code number.

Example:

151-6004 for an OMR 160 with A4 flange, cyl. 32 mm shaft, port size G 1/2 and side port version.

---

Orders will not be accepted without the four digit prefix.

---

Technical data for OMR with 25 mm and 1 in cylindrical shaft

Type		OMR	OMR	OMR	OMR	OMR	OMR	OMR	OMR	OMR	
Motor size		50	80	100	125	160	200	250	315	375	
Geometric displacement	cm <sup>3</sup> [inch]	51.6 [3.16]	80.3 [4.91]	99.8 [6.11]	125.7 [7.69]	159.6 [9.77]	199.8 [12.23]	249.3 [15.26]	315.7 [19.32]	372.6 [22.80]	
Max. speed	min <sup>-1</sup> [rpm]	cont.	775	750	600	475	375	300	240	190	160
		int. <sup>1)</sup>	970	940	750	600	470	375	300	240	200
Max. torque	N·m [lbf·in]	cont.	100 [890]	195 [1730]	240 [2120]	300 [2660]	300 [2660]	300 [2660]	300 [2660]	300 [2660]	300 [2660]
		int. <sup>1)</sup>	130 [1150]	220 [1960]	280 [2480]	340 [3010]	390 [3450]	390 [3450]	380 [3360]	420 [3720]	430 [3810]
		peak <sup>2)</sup>	170 [1510]	270 [2390]	320 [2830]	370 [3280]	460 [4070]	560 [4960]	600 [5310]	610 [5400]	600 [5310]
Max. output	kW [hp]	cont.	7.0 [9.4]	12.5 [16.8]	13.0 [17.4]	12.5 [16.8]	10.0 [13.4]	8.0 [10.7]	6.0 [8.1]	5.0 [6.7]	4.0 [5.4]
		int. <sup>1)</sup>	8.5 [11.4]	15.0 [20.1]	15.0 [20.1]	14.5 [19.4]	12.5 [16.8]	10.0 [13.4]	8.0 [10.7]	6.5 [8.7]	6.0 [8.1]
Max. pressure drop	bar [psi]	cont.	140 [2030]	175 [2540]	175 [2540]	175 [2540]	130 [1890]	110 [1600]	80 [1160]	70 [1020]	55 [800]
		int. <sup>1)</sup>	175 [2540]	200 [2900]	200 [2900]	200 [2900]	175 [2540]	140 [2030]	110 [1600]	100 [1450]	85 [1230]
		peak <sup>2)</sup>	225 [3260]	225 [3260]	225 [3260]	225 [3260]	225 [3260]	225 [3260]	200 [2900]	150 [2180]	130 [1890]
Max. oil flow	l/min [US gal/min]	cont.	40 [10.6]	60 [15.9]	60 [15.9]	60 [15.9]	60 [15.9]	60 [15.9]	60 [15.9]	60 [15.9]	60 [15.9]
		int. <sup>1)</sup>	50 [13.2]	75 [19.8]	75 [19.8]	75 [19.8]	75 [19.8]	75 [19.8]	75 [19.8]	75 [19.8]	75 [19.8]
Max. starting pressure with unloaded shaft	bar [psi]	10 [145]	10 [145]	10 [145]	9 [130]	7 [100]	5 [75]	5 [75]	5 [75]	5 [75]	
Min starting torque	at max. press drop cont. N·m [lbf·in]	80 [710]	150 [1330]	200 [1770]	250 [2210]	240 [2120]	260 [2300]	240 [2120]	260 [2300]	240 [2120]	
	at max. press.drop int. <sup>1)</sup> N·m [lbf·in]	100 [890]	170 [1510]	230 [2040]	280 [2480]	320 [2830]	330 [2920]	310 [2740]	350 [3100]	380 [3360]	

<sup>1)</sup> Intermittent operation: the permissible values may occur for max. 10% of every minute.

<sup>2)</sup> Peak load: the permissible values may occur for max. 1% of every minute.

Technical data for OMR with 1 in splined and 28.5 mm tapered shaft

Type		OMR	OMR	OMR	OMR	OMR	OMR	OMR	OMR	OMR	
Motor size		50	80	100	125	160	200	250	315	375	
Geometric displacement	cm <sup>3</sup> [inch]	51.6 [3.16]	80.3 [4.91]	99.8 [6.11]	125.7 [7.69]	159.6 [9.77]	199.8 [12.23]	249.3 [15.26]	315.7 [19.32]	372.6 [22.80]	
Max. speed	min <sup>-1</sup> [rpm]	cont.	775	750	600	475	375	300	240	190	160
		int. <sup>1)</sup>	970	940	750	600	470	375	300	240	200
Max. torque	N•m [lbf•in]	cont.	100 [890]	195 [1730]	240 [2120]	300 [2660]	360 [3190]	360 [3190]	360 [3190]	360 [3190]	360 [3190]
		int. <sup>1)</sup>	130 [1150]	220 [1950]	280 [2480]	340 [3010]	430 [3810]	440 [3890]	470 [4160]	470 [4160]	460 [4070]
		peak <sup>2)</sup>	170 [1510]	270 [2390]	320 [2830]	370 [3280]	460 [4070]	560 [4960]	600 [5310]	610 [5400]	600 [5310]
Max. output	kW [hp]	cont.	7.0 [9.4]	12.5 [16.8]	13.0 [17.4]	12.5 [16.8]	12.5 [16.8]	10.0 [13.4]	7.0 [9.4]	5.0 [6.7]	5.0 [6.7]
		int. <sup>1)</sup>	8.5 [11.4]	15.0 [20.1]	15.0 [20.1]	14.5 [19.4]	14.0 [18.8]	13.0 [17.4]	9.5 [12.7]	8.0 [10.7]	7.0 [9.4]
Max. pressure drop	bar [psi]	cont.	140 [2030]	175 [2540]	175 [2540]	175 [2540]	165 [2390]	130 [1890]	100 [1450]	85 [1230]	70 [1020]
		int. <sup>1)</sup>	175 [2540]	200 [2900]	200 [2900]	200 [2900]	200 [2900]	175 [2540]	140 [2030]	115 [1670]	90 [1310]
		peak <sup>2)</sup>	225 [3260]	225 [3260]	225 [3260]	225 [3260]	225 [3260]	225 [3260]	200 [2900]	150 [2180]	130 [1890]
Max. oil flow	l/min [US gal/min]	cont.	40 [10.6]	60 [15.9]	60 [15.9]	60 [15.9]	60 [15.9]	60 [15.9]	60 [15.9]	60 [15.9]	60 [15.9]
		int. <sup>1)</sup>	50 [13.2]	75 [19.8]	75 [19.8]	75 [19.8]	75 [19.8]	75 [19.8]	75 [19.8]	75 [19.8]	75 [19.8]
Max. starting pressure with unloaded shaft	bar [psi]	10 [145]	10 [145]	10 [145]	9 [130]	7 [100]	5 [75]	5 [75]	5 [75]	5 [75]	
Min starting torque	at max. press drop cont.	80 [710]	150 [1330]	200 [1770]	250 [2210]	300 [2660]	300 [2660]	290 [2570]	315 [2790]	300 [2660]	
	at max. press.drop int. <sup>1)</sup>	100 [890]	170 [1510]	230 [2040]	280 [2480]	350 [3100]	400 [3540]	400 [3540]	400 [3540]	380 [3360]	

<sup>1)</sup> Intermittent operation: the permissible values may occur for max. 10% of every minute.

<sup>2)</sup> Peak load: the permissible values may occur for max. 1% of every minute.

Technical data for OMR with 32 mm , 1 ¼ in cylindrical shaft and 35 mm, 1 ¼ in tapered shaft

Type		OMR	OMR	OMR	OMR	OMR	OMR	OMR	OMR	OMR	
Motor size		50	80	100	125	160	200	250	315	375	
Geometric displacement	cm <sup>3</sup> [inch]	51.6 [3.16]	80.3 [4.91]	99.8 [6.11]	125.7 [7.69]	159.6 [9.77]	199.8 [12.23]	249.3 [15.26]	315.7 [19.32]	372.6 [22.80]	
Max. speed	min <sup>-1</sup> [rpm]	cont.	775	750	600	475	375	300	240	190	160
		int. <sup>1)</sup>	970	940	750	600	470	375	300	240	200
Max. torque	N•m [lbf•in]	cont.	100 [890]	195 [1730]	240 [2120]	300 [2660]	380 [3360]	450 [3980]	540 [4780]	550 [4870]	580 [5130]
		int. <sup>1)</sup>	130 [1150]	220 [1957]	280 [2480]	340 [3010]	430 [3810]	500 [4430]	610 [5400]	690 [6110]	690 [6110]
		peak <sup>2)</sup>	170 [1510]	270 [2390]	320 [2830]	370 [3280]	460 [4070]	560 [4960]	710 [6280]	840 [7440]	830 [7350]
Max. output	kW [hp]	cont.	7.0 [9.4]	12.5 [16.8]	13.0 [17.4]	12.5 [16.8]	12.5 [16.8]	11.0 [14.8]	10.0 [13.4]	9.0 [12.1]	7.5 [10.1]
		int. <sup>1)</sup>	8.5 [11.4]	15.0 [20.1]	15.0 [20.1]	14.5 [19.4]	14.0 [18.8]	13.0 [17.4]	12.0 [16.1]	10.0 [13.4]	9.0 [12.1]
Max. pressure drop	bar [psi]	cont.	140 [2030]	175 [2540]	175 [2540]	175 [2540]	175 [2540]	175 [2540]	175 [2540]	135 [1960]	115 [1670]
		int. <sup>1)</sup>	175 [2540]	200 [2900]	200 [2900]	200 [2900]	200 [2900]	200 [2900]	200 [2900]	175 [2540]	150 [2180]
		peak <sup>2)</sup>	225 [3260]	225 [3260]	225 [3260]	225 [3260]	225 [3260]	225 [3260]	225 [3260]	225 [3260]	210 [3050]
Max. oil flow	l/min [US gal/min]	cont.	40 [10.6]	60 [15.9]	60 [15.9]	60 [15.9]	60 [15.9]	60 [15.9]	60 [15.9]	60 [15.9]	60 [15.9]
		int. <sup>1)</sup>	50 [13.2]	75 [19.8]	75 [19.8]	75 [19.8]	75 [19.8]	75 [19.8]	75 [19.8]	75 [19.8]	75 [19.8]
Max. starting pressure with unloaded shaft	bar [psi]	10 [145]	10 [145]	10 [145]	9 [130]	7 [100]	5 [75]	5 [75]	5 [75]	5 [75]	
Min starting torque	at max. press drop cont.	80 [710]	150 [1330]	200 [1770]	250 [2210]	320 [2830]	410 [3630]	500 [4430]	500 [4430]	470 [4170]	
	at max. press.drop int. <sup>1)</sup>	100 [890]	170 [1510]	230 [2040]	280 [2480]	370 [3280]	460 [4070]	550 [4870]	660 [5840]	570 [5050]	

Type		Max. inlet pressure	Max.return pressure with drain line
OMR 50 - 375	bar [psi]	cont	175 [2540]
	bar [psi]	int. <sup>1)</sup>	200 [2900]
	bar [psi]	peak <sup>2)</sup>	225 [3260]

<sup>1)</sup> Intermittent operation: the permissible values may occur for max. 10% of every minute.

<sup>2)</sup> Peak load: the permissible values may occur for max. 1% of every minute.

**Technical Data for  
 Parking Brake Motor  
 OMR F, OMR NF and  
 OMRW NF**

Technical data for brake motor		
Holding torque 1)	N·m [lbf·in]	400 [3540]
Min. release pressure 2)	bar [psi]	21 [305]
Max. pressure in brake line	bar [psi]	200 [2900]

- 1) This brake is to be used only as a passive parking brake. It may not be used for dynamic braking.
- 2) Brake motors must always have a drain line. The brake release pressure is the difference between the pressure in the brake release line and the pressure in the drain line.

**Function**

In normal condition where there is no pressure on the integrated brake in OMR, i.e. the brake is applied. The brake is released when hydraulic pressure of 21 bar [300psi] min. is applied to the brake release port (1). The pressure forces the piston (2) against the springs (3 and 4) disengaging the outer and inner discs (5 and 6) from each other so that the cardan shaft (7) and consequently output shaft (8) become free to rotate. If the pressure on the brake release port is reduced to less than 21 bar [300psi], the springs force the piston and pressure pad (9) against the brake discs and the cardan shaft/output shaft begin to lock up.

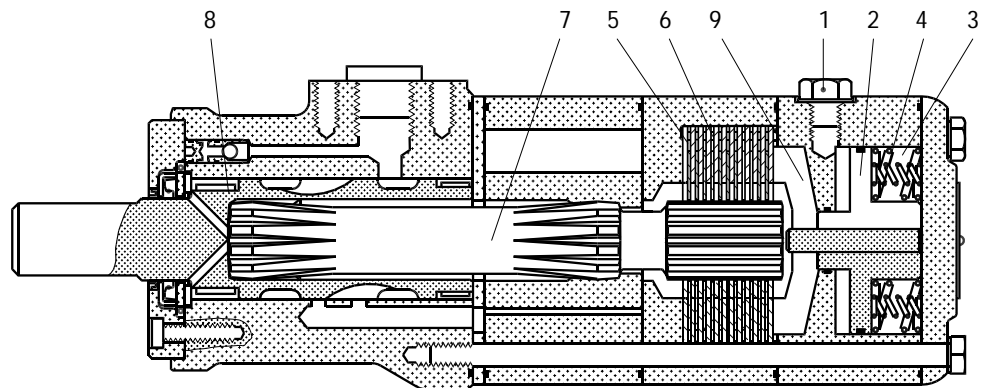

151-1739.10.10

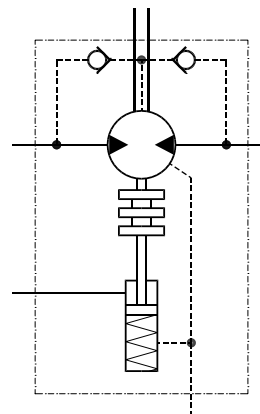

151-1726.10

Technical Data - Max. Permissible Shaft Seal Pressure

OMR with High Pressure Shaft Seal (HPS)

OMR with HPS, without check valves and without drain connection:  
The shaft seal pressure equals the average of input pressure and return pressure

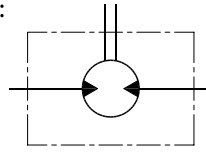

151-1743.10

$$P_{\text{seal}} = \frac{P_{\text{in}} + P_{\text{return}}}{2}$$

Max. permissible shaft seal pressure

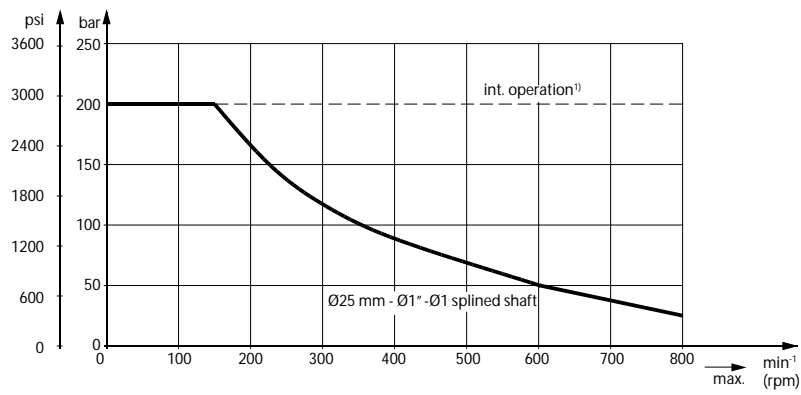

151-1856.10

OMR with Standard Shaft Seal

OMR with standard shaft seal, check valves and without use of drain connection:  
The pressure on the shaft seal never exceeds the pressure in the return line

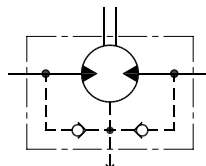

151-320.10

OMR with standard shaft seal, check valves and with drain connection:  
The shaft seal pressure equals the pressure on the drain line.

Max. return pressure without drain line or max. pressure in the drain line

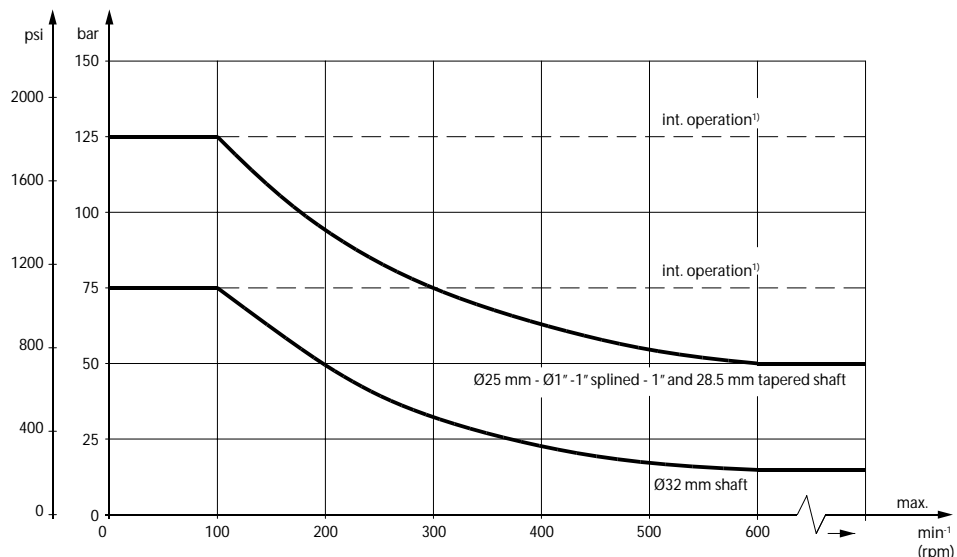

151-1563.10

¹) Intermittent operation: the permissible values may occur for max. 10% of every minute.

**Pressure Drop in Motor**

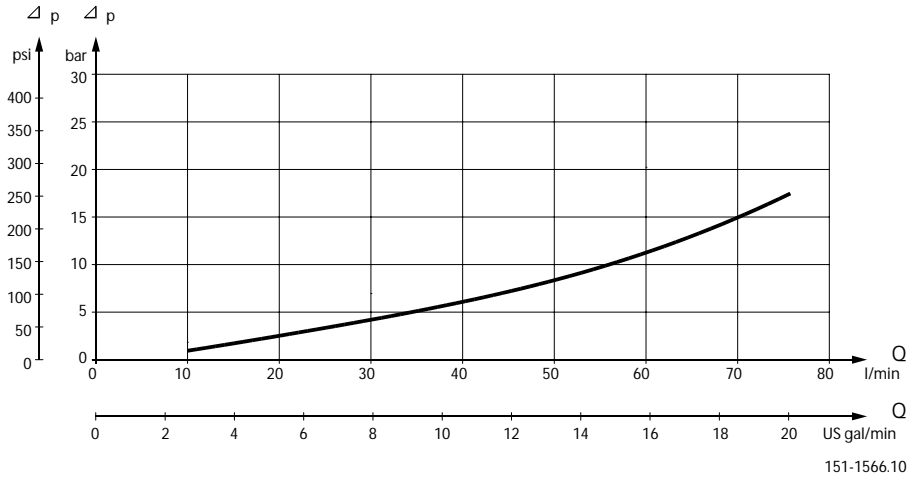

The curve applies to an unloaded motor shaft and an oil viscosity of 35 mm<sup>2</sup>/s [165 SUS]

**Oil Flow in Drain Line**

The table shows the max. oil flow in the drain line at a return pressure less than 5-10 bar [75-150 psi].

Pressure drop bar [psi]	Viscosity mm <sup>2</sup> /s [SUS]	Oil flow in drain line l/min [US gal/min]
100 [1450]	20 [100]	2.5 [0.66]
	35 [165]	1.8 [0.78]
140 [2030]	20 [100]	3.5 [0.93]
	35 [165]	2.8 [0.74]

**Direction of Shaft  
 Rotation**

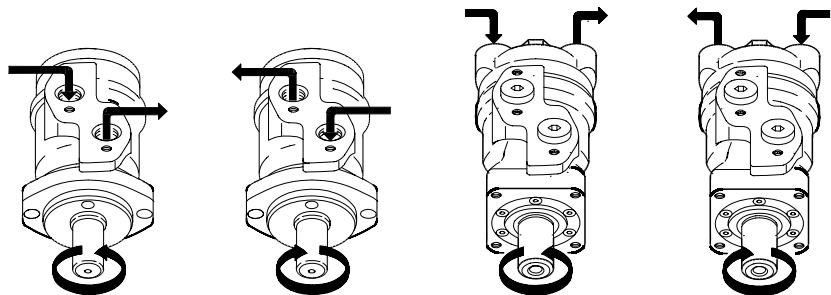

151-1836.10



**Permissible Shaft Loads  
 for OMR**

The permissible radial shaft load ( $P_R$ ) depends on

- Speed ( $n$ )
- Distance ( $L$ ) from the point of load to the mounting flange
- Mounting flange version
- Shaft version

Mounting ange	4-oval ange** 2-hole oval ange (European version)	4-hole oval ange	Square ange** 2-hole oval ange (US-version)
Shaft version	25 mm cylindrical shaft 1 in cylindrical shaft 1 in splined shaft	32 mm cylindrical shaft	25 mm cylindrical shaft
Permissible shaft load ( $P_R$ ) - l in mm	$\frac{800}{n} \cdot \frac{250000}{95 + L} N^*$	$\frac{800}{n} \cdot \frac{187500}{95 + L} N^*$	$\frac{800}{n} \cdot \frac{250000}{101 + L} N^*$
Permissible shaft load ( $P_R$ ) - l in inch	$\frac{800}{n} \cdot \frac{2215}{3.74 + L} lbf^*$	$\frac{800}{n} \cdot \frac{1660}{3.74 + L} lbf^*$	$\frac{800}{n} \cdot \frac{2215}{3.98 + L} lbf^*$

\*  $n \geq 200 \text{ min}^{-1}$  [rpm];  $\leq 55 \text{ mm}$  [2.2 in]  
 $n < 200 \text{ min}^{-1}$  [rpm];  $= > P_{Rmax} = 8000 \text{ N}$  [1800 lbf]  
 \*\* For both European and US-version

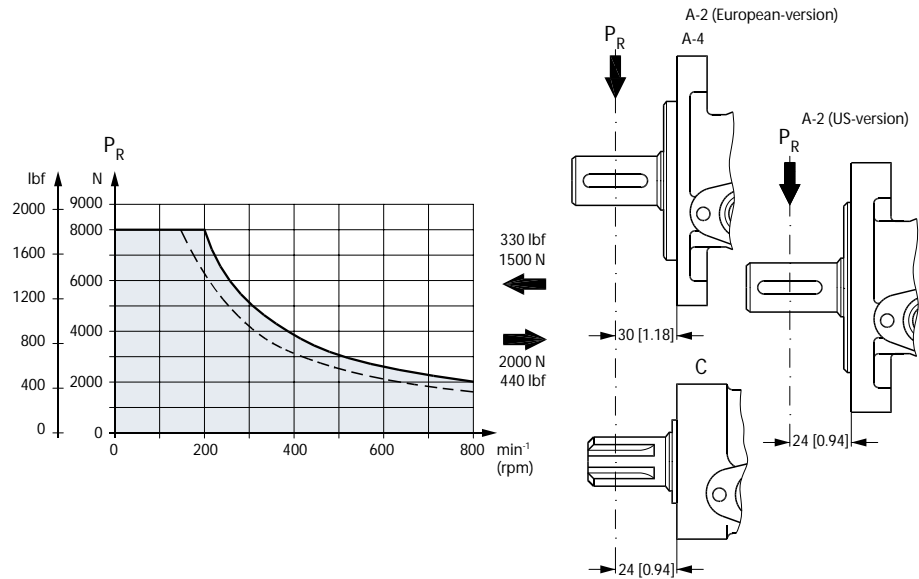

151-1203.10

----- cylindrical shaft 32 mm [1.26 in]  
 \_\_\_\_\_ other shaft versions

The curve shows the relation between  $P_R$  and  $n$

- when  $l = 30 \text{ mm}$  [1.18 in] for motors with A2 (European version) and A4 oval mounting flange
- when  $l = 24 \text{ mm}$  [0.94 in] for motors with square mounting flange and A2 (US version)

For applications with special performance requirements we recommend OMR with the output shaft running in needle bearings.

Permissible Shaft Load  
 for OMR N and OMR NF  
 with Needle Bearings

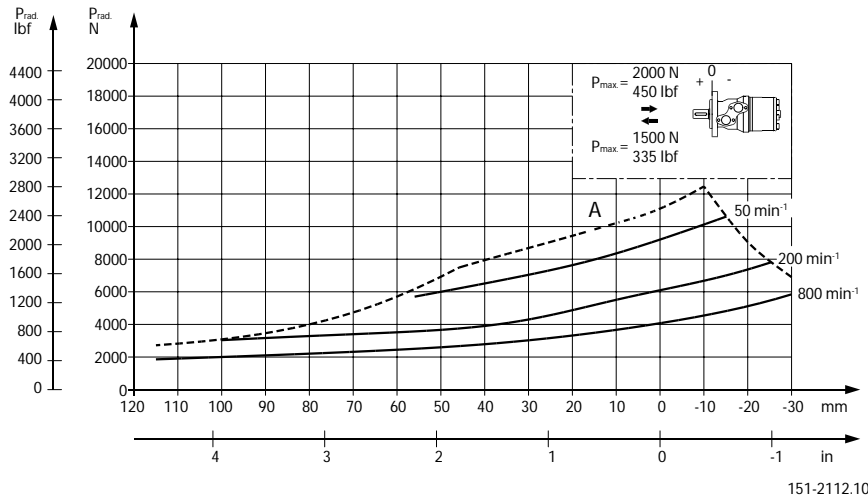

The output shaft on OMR N and OMR NF runs in needle bearings. These bearings and the recessed mounting flange allow a higher permissible radial load in comparison to OMR motors with slide bearings.

The permissible radial load on the shaft is shown for different speeds as a function of the distance from the mounting flange to the point of load application.

Curve A shows max. radial shaft load. Any shaft load exceeding the values quoted in the curve will involve a risk of breakage.

The other curves apply to a B10 bearing life of 2000 hours at the number of revolutions indicated by the curve letter. Mineral based hydraulic oil with a sufficient content of anti-wear additives must be used.

Bearing life calculations can be made using the explanation and formula provided in the chapter »Bearing dimensioning« in the technical information "General" DHMH.PK.100. G2.02 520L0232.

**Permissible Shaft Load  
for OMRW N and OMRW  
NF with Needle Bearings**

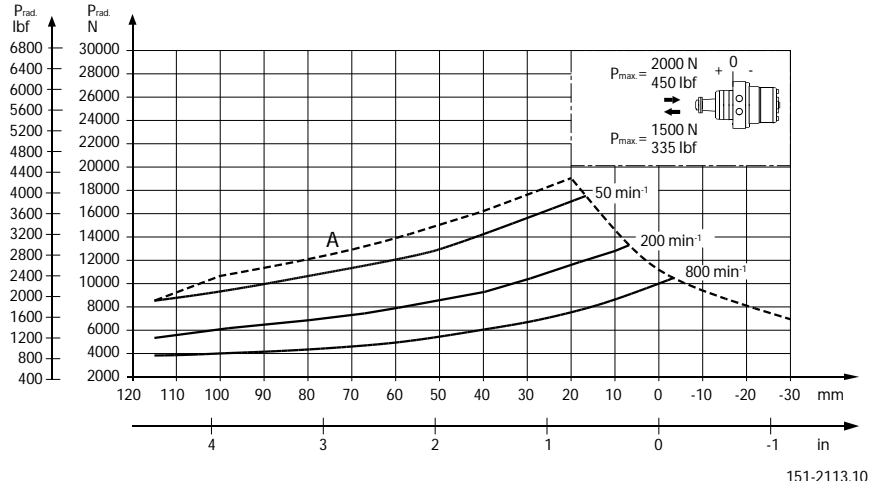

The output shaft on OMRW N runs in needle bearings. These bearings and the recessed mounting flange allow a higher permissible radial load in comparison to OMR motors with slide bearings.

The permissible radial load on the shaft is shown for different speeds as a function of the distance from the mounting flange to the point of load application.

Curve A shows max. radial shaft load. Any shaft load exceeding the values quoted in the curve will involve a risk of breakage.

The other curves apply to a B10 bearing life of 2000 hours at the number of revolutions indicated by the curve letter. Mineral based hydraulic oil with a sufficient content of anti-wear additives must be used.

Bearing life calculations can be made using the explanation and formula provided in the chapter »Bearing dimensioning« in the technical information "General" DHMH.PK.100. G2.02 520L0232.

Function Diagrams

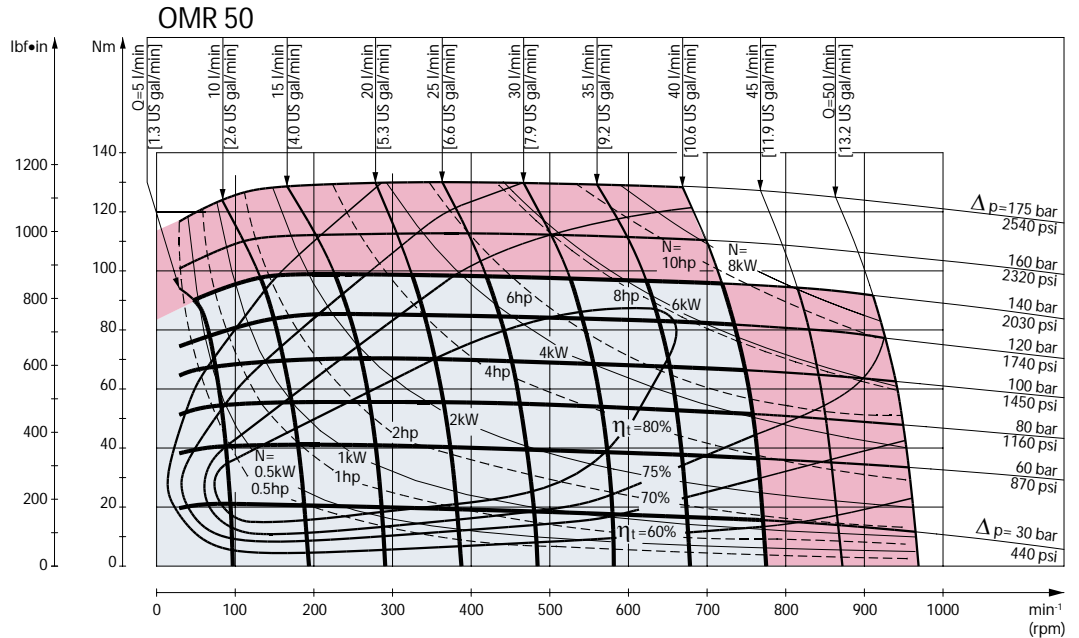

151-1172.10

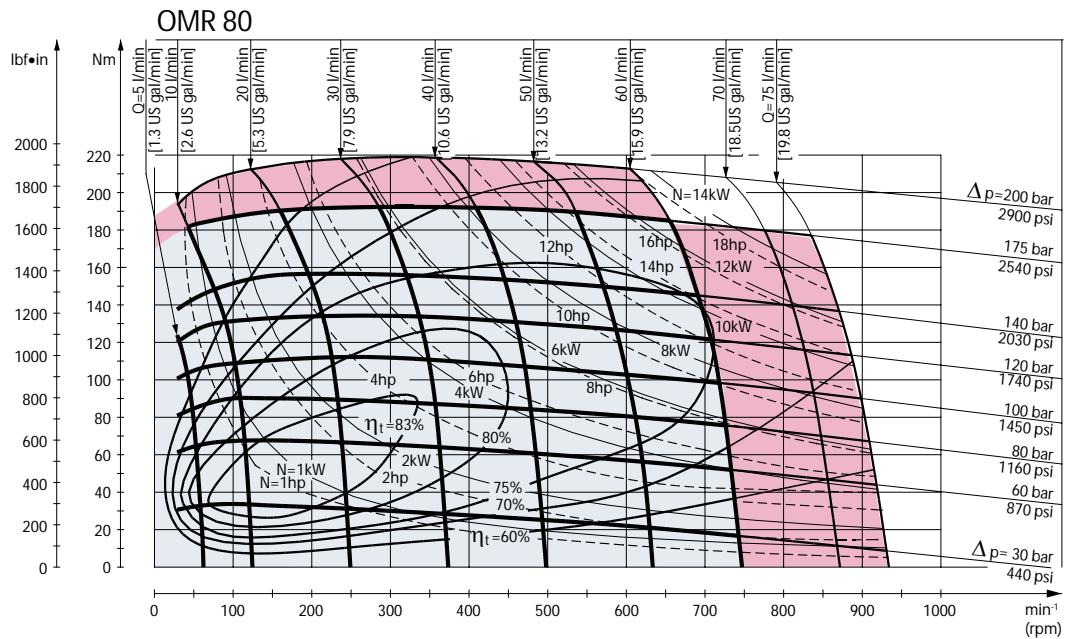

151-299.10

Explanation of function diagram use, basis and conditions can be found on page 7.

Continuous range

Intermittent range (max. 10% operation every minute)

Max. permissible continuous/intermittent pressure drop for the actual shaft version can be found on page 42 - 44.

Intermittent pressure drop and oil flow must not occur simultaneously.

Function Diagrams

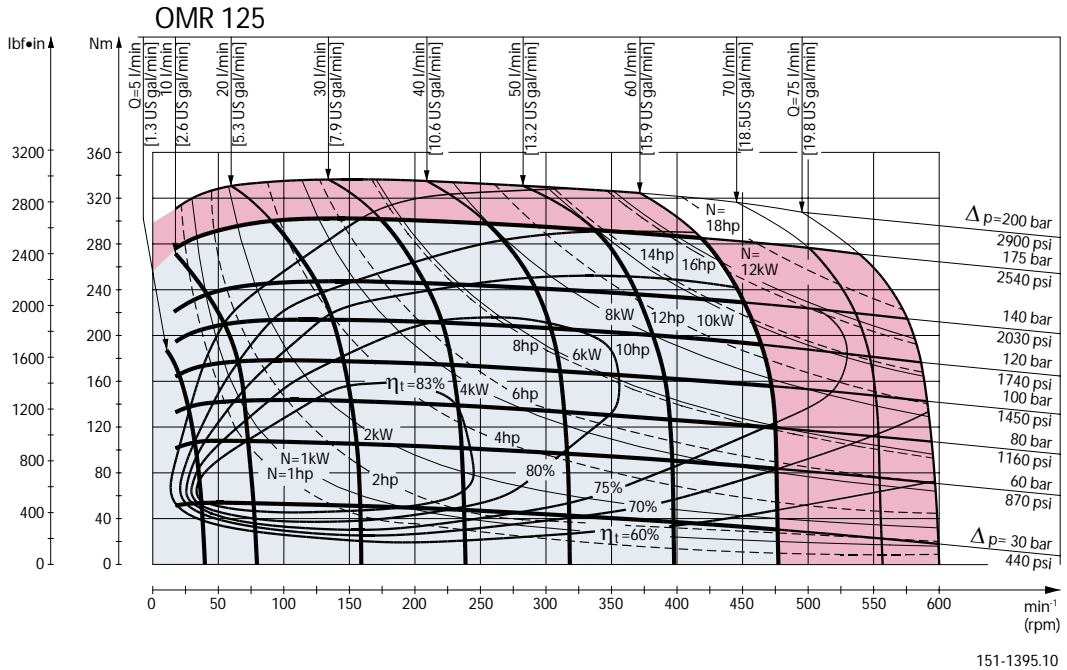
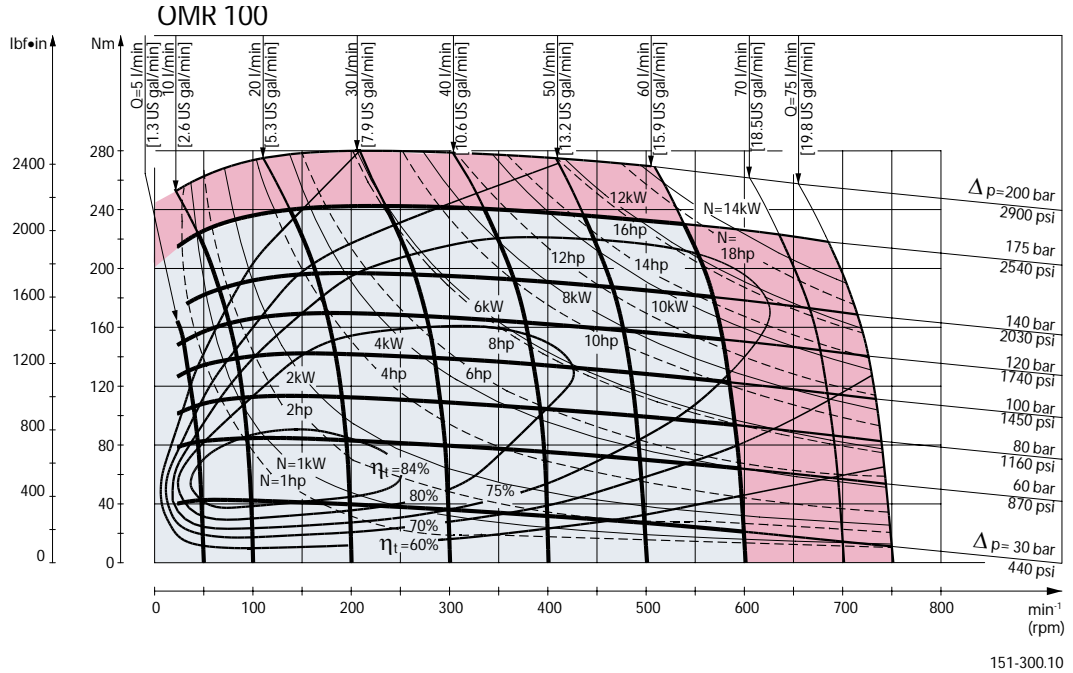

Explanation of function diagram use, basis and conditions can be found on page 7.

Continuous range

Intermittent range (max. 10% operation every minute)

Max. permissible continuous/intermittent pressure drop for the actual shaft version can be found on page 42 - 44.

Intermittent pressure drop and oil flow must not occur simultaneously.

Function Diagrams

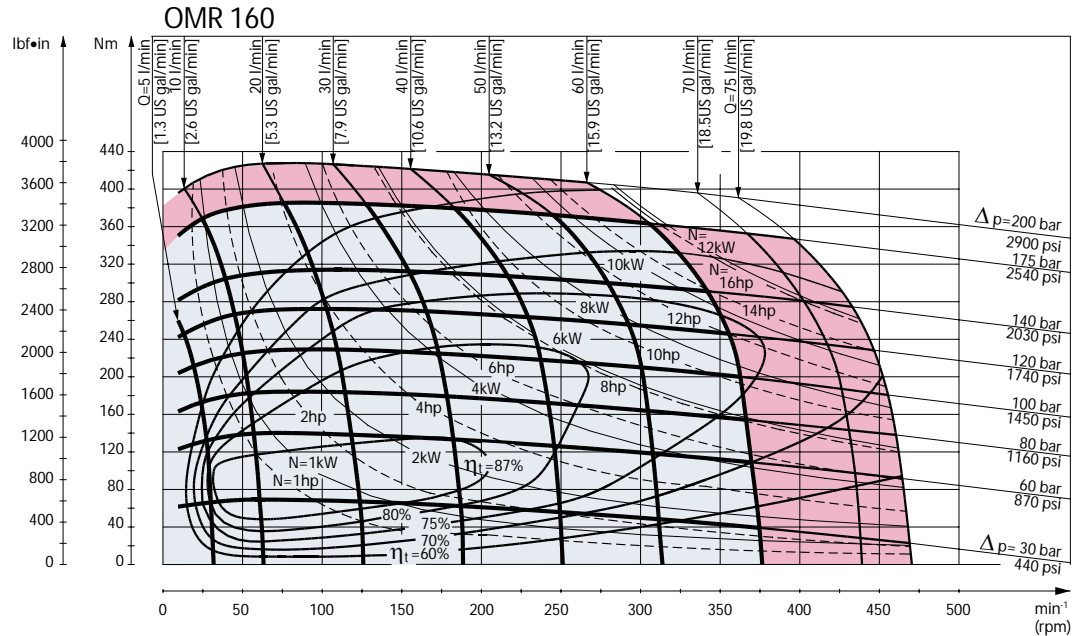

151-1044.10

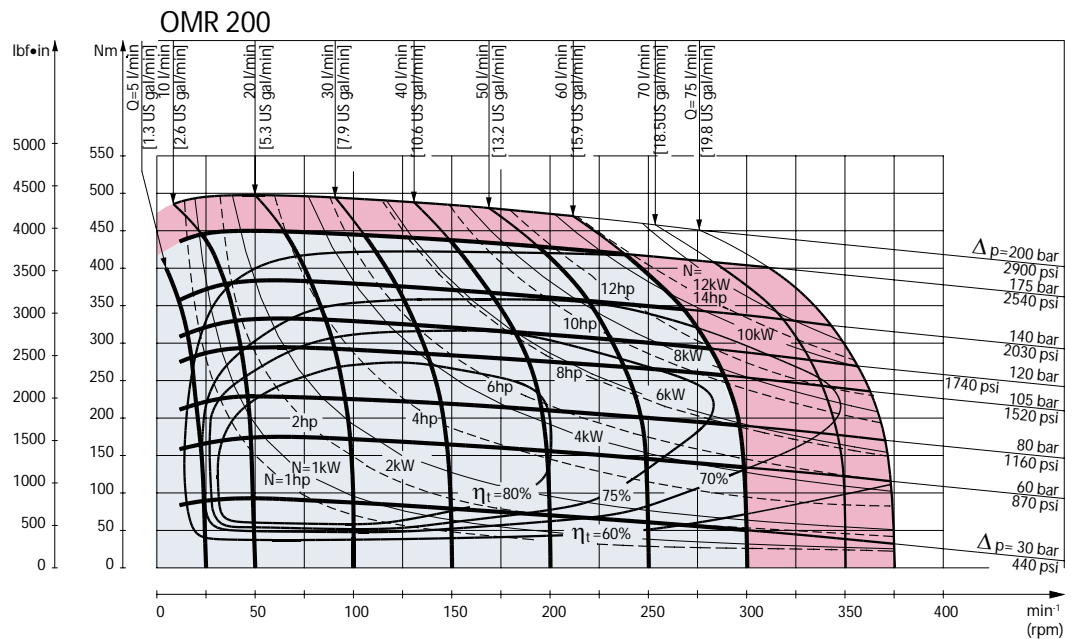

151-1396.10

Explanation of function diagram use, basis and conditions can be found on page 7.

■ Continuous range

■ Intermittent range (max. 10% operation every minute)

Max. permissible continuous/intermittent pressure drop for the actual shaft version can be found on page 42 - 44.

Intermittent pressure drop and oil flow must not occur simultaneously.

Function Diagrams

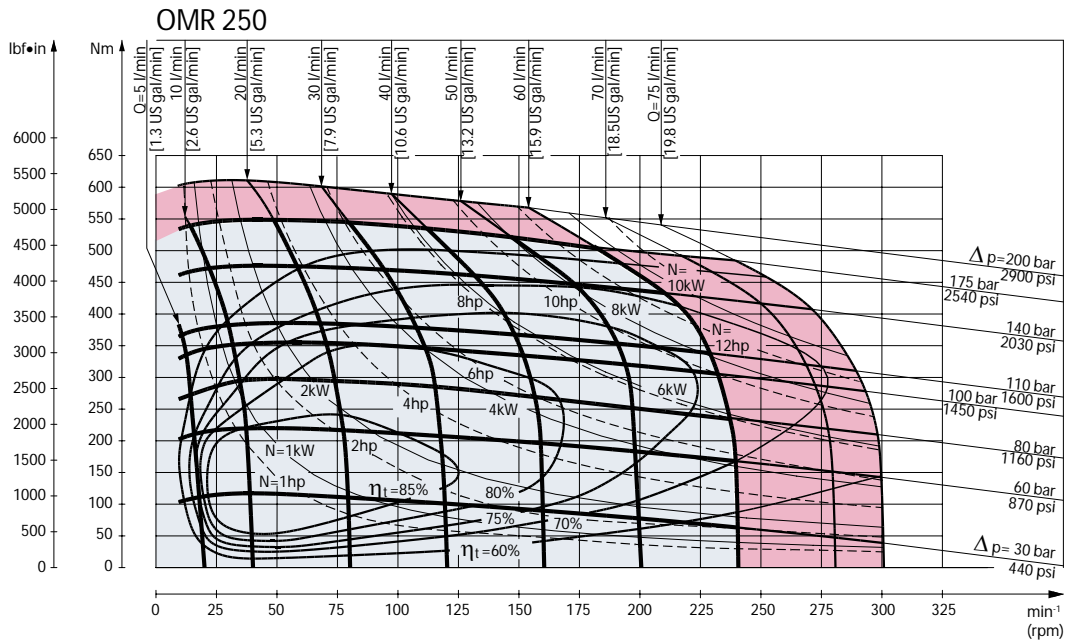

151-1119.10

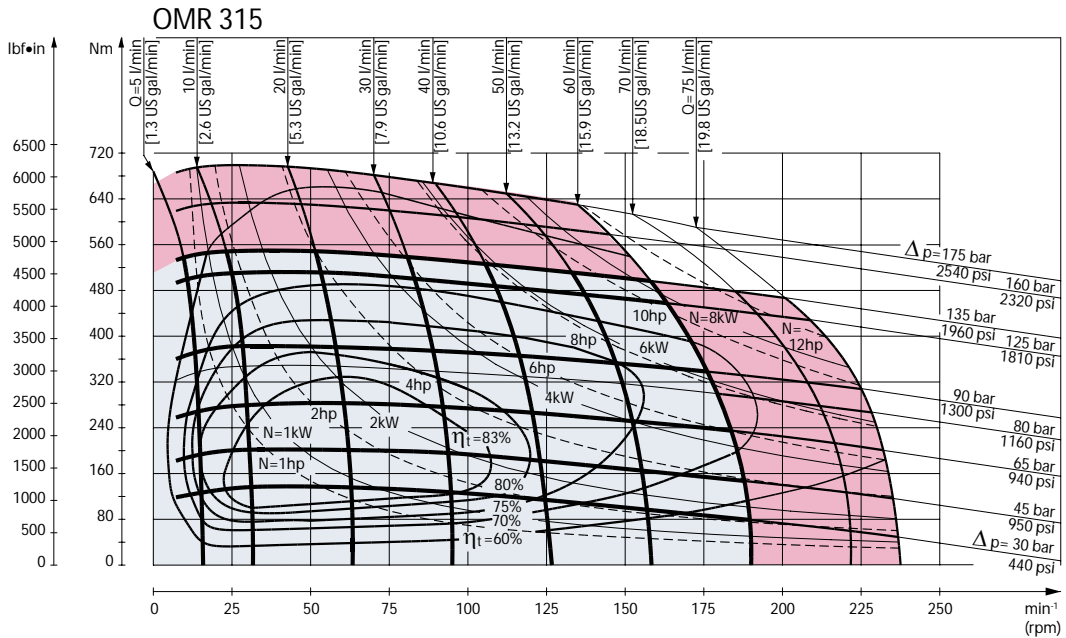

151-809.10

Explanation of function diagram use, basis and conditions can be found on page 7.

- Continuous range
- Intermittent range (max. 10% operation every minute)

Max. permissible continuous/intermittent pressure drop for the actual shaft version can be found on page 42 - 44.

Intermittent pressure drop and oil flow must not occur simultaneously.

Function Diagrams

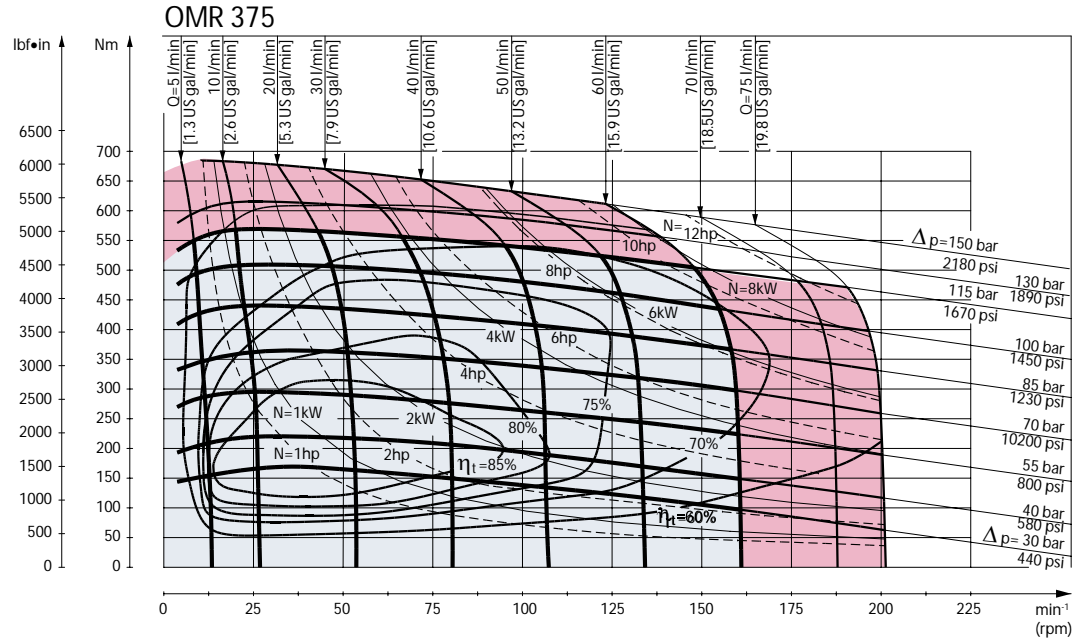

151-1385.11

Explanation of function diagram use, basis and conditions can be found on page 7.

■ Continuous range

■ Intermittent range (max. 10% operation every minute)

Max. permissible continuous/intermittent pressure drop for the actual shaft version can be found on page 42 - 44.

---

Intermittent pressure drop and oil flow must not occur simultaneously.

---



Shaft Version

A: Cylindrical shaft  
25 mm  
D: Parallel key  
A8 • 7 • 32  
DIN 6885

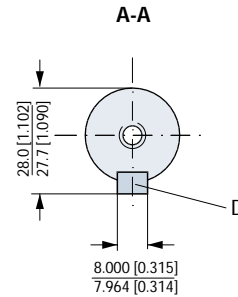
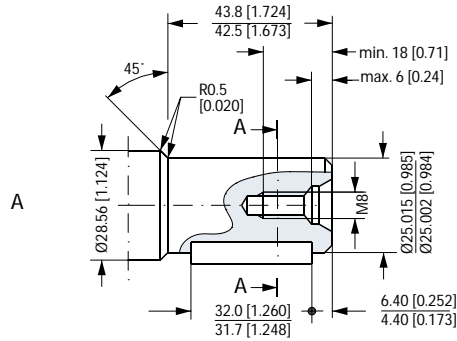

B: Cylindrical shaft 1 in  
E: Parallel key  
1/4 • 1/4 • 1 1/4 in  
B.S. 46

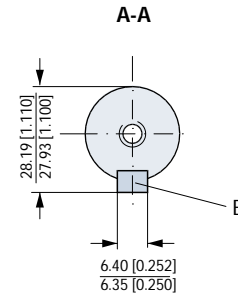
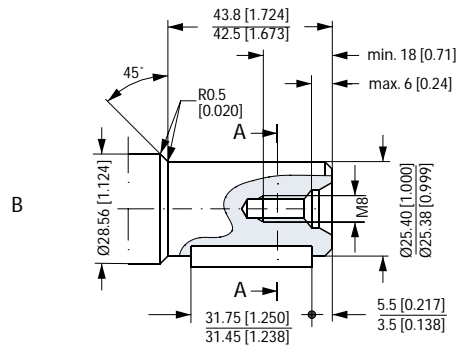

US version

C: Cylindrical shaft  
1 in  
F: Parallel key  
1/4 • 1/4 • 1 1/4 in  
B.S. 46

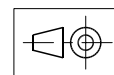
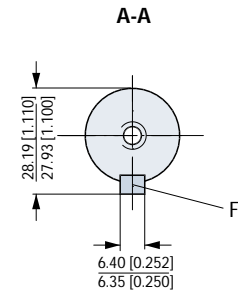
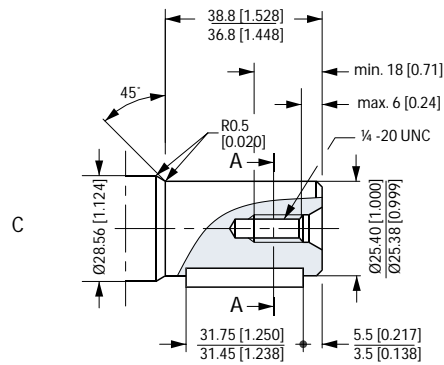

Shaft Version

D: Cylindrical shaft  
 32 mm  
 G: Parallel key  
 A10 • 8 • 45  
 DIN 6885

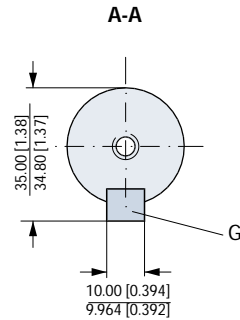
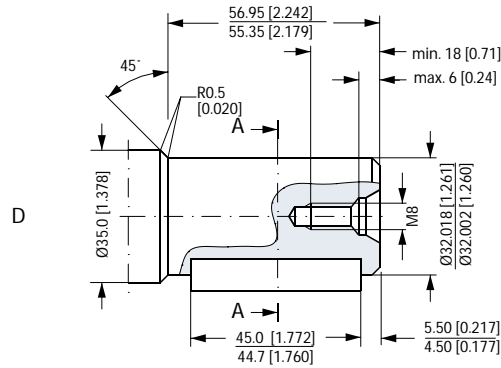

US version  
 E: Cylindrical shaft  
 1 ¼ in  
 H: Parallel key  
 5/16 • 5/16 • 1 ¼ in  
 B.S. 46

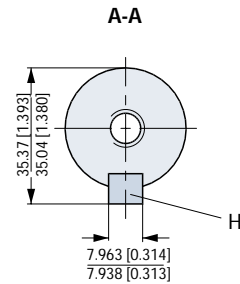
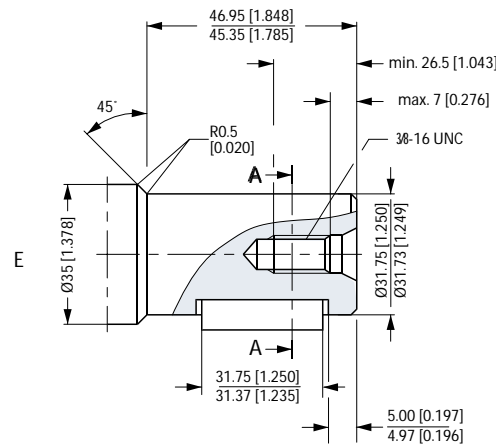

F: Involute splined shaft  
 B.S. 2059 (SAE 6 B)

Straight-sided,  
 bottom fitting, deep.  
 Fit 2  
 Nom. size 1 in

\*Deviates from  
 B.S. 2059 (SAE 6 B)

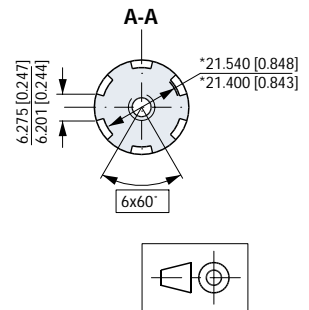
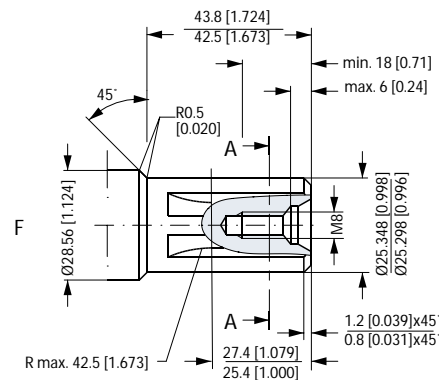

151-1851.12

Shaft Version

US version

- G: Splined shaft
- SAE 6 B (B.S. 2059)
- Straight-sided,
- bottom fitting, deep.
- Fit 2
- Nom. size 1 in
- \* Deviates from
- SAE 6 B (B.S. 2059)

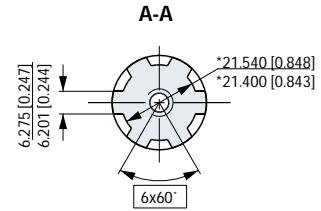
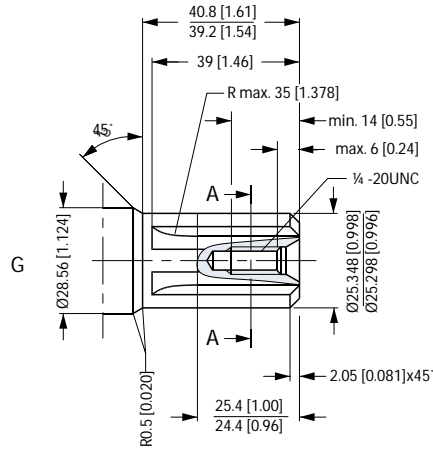

- H: Tapered shaft 28.5 mm (ISO/R775)
- K: DIN 937 NV 30
- Tightening torque: 100 ± 10 N·m [885 ± 85 lbf·in]
- J: Taper 1:10
- L: Parallel key B5 · 5 · 14 DIN 6885

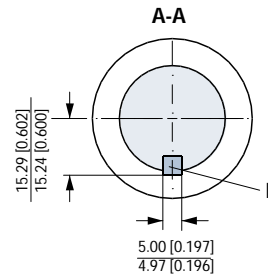
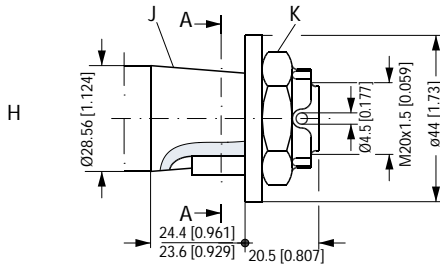

- I: Tapered shaft 35 mm
- N: DIN 937 NV 41
- Tightening torque: 200 ± 10 N·m [1770 ± 85 lbf·in]
- M: Taper 1:10
- P: Parallel key B6 · 6 · 20 DIN 6885

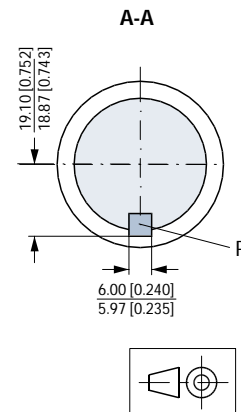
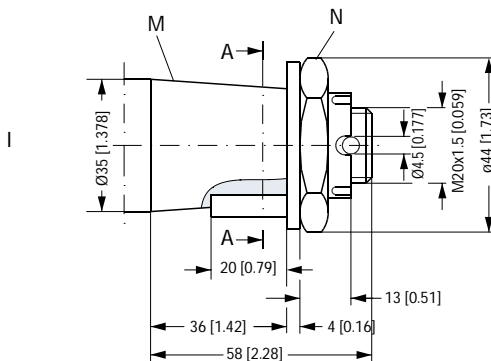

151-1847 11

Shaft Version

- J: Tapered shaft 1 1/4 in
- K: Cone 1:8  
SAE J501
- L: 1 - 20 UNEF  
Across flats 1 7/16  
Tightening torque:  
200 ± 10 Nm [1770 ± 85 lbf-in]
- M: Parallel key  
5/16 • 5/16 • 1 1/4  
SAE J501

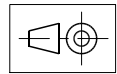
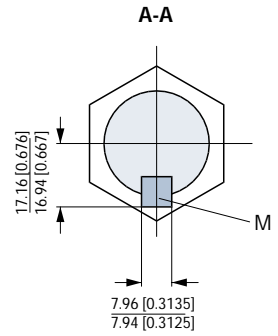
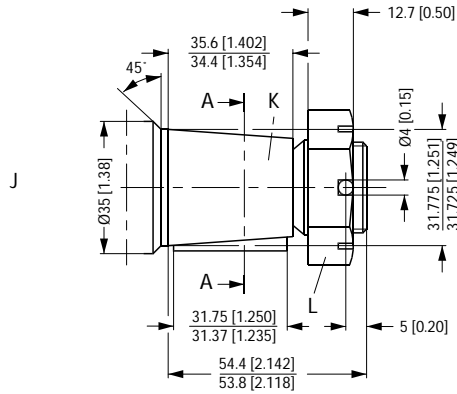

151-1848.11

Port Thread Versions

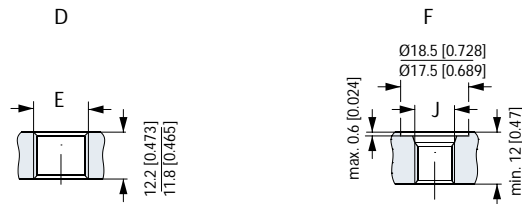
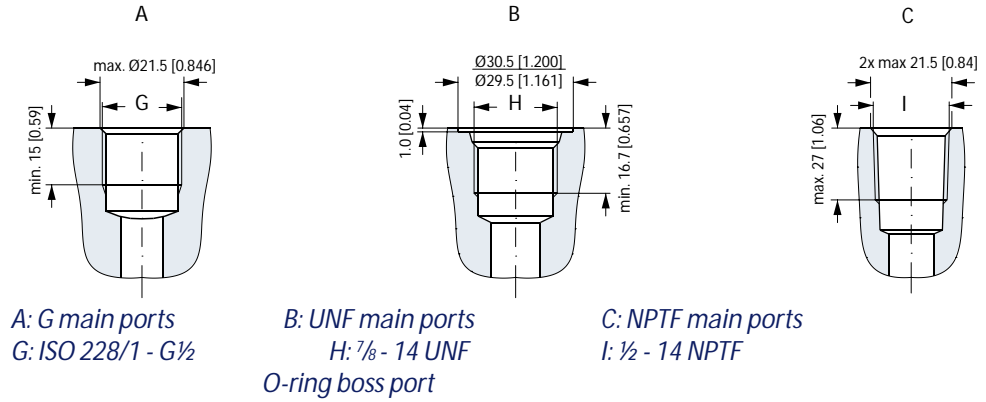

*D: G drain port  
E: ISO 228/1 - G¼  
O-ring boss port*

*F: UNF drain port  
J: 7/16 - 20 UNF*

151-1844.11

Manifold Mount

European version

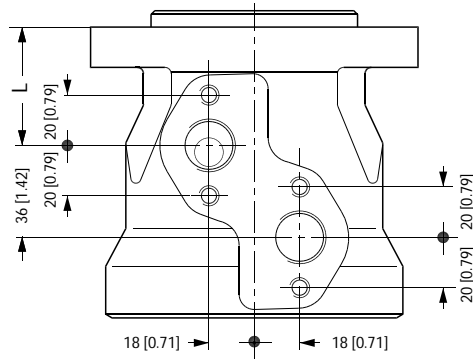

*L: see dimensional drawing for given OMR motor on pages 61- 74*

151-2135.10

**Dimensions**

*Side port version with 2-hole oval mounting angle (A2 angle).  
 With high pressure shaft seal*

Type	Max. L mm [in]	L <sub>1</sub> mm [in]
OMR 50	136.5 [5.37]	9.0 [0.35]
OMR 80	141.5 [5.57]	14.0 [0.55]
OMR 100	145.0 [5.71]	17.4 [0.69]
OMR 125	149.5 [5.89]	21.8 [0.86]
OMR 160	155.5 [6.12]	27.8 [1.09]
OMR 200	162.5 [6.40]	34.8 [1.37]
OMR 250	171.5 [6.75]	43.5 [1.71]
OMR 315	182.5 [7.19]	54.8 [2.16]
OMR 375	192.7 [7.59]	65.0 [2.56]

D: G ½; 15 mm [0.59 in] deep  
 E: M8; 13 mm [0.51 in] deep  
 (4 pcs.)

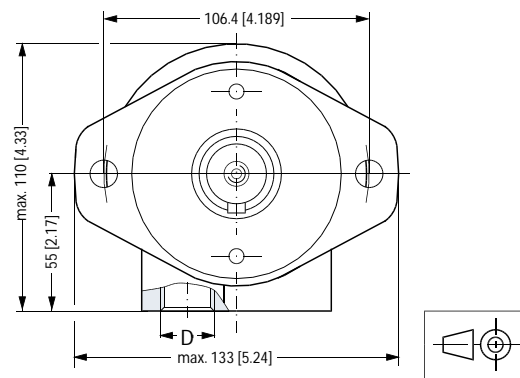
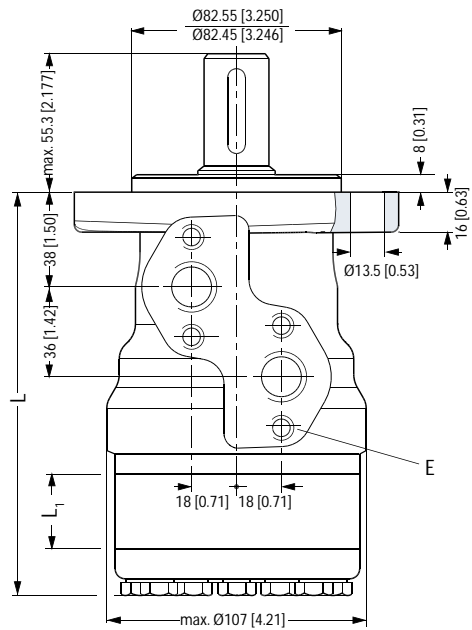

151-1750.11

**Dimensions**

*Side port version with 2-hole oval mounting angle (A2 angle).  
 With check valves and drain connection.  
 With high pressure shaft seal.*

Type	Max. L mm [in]	L <sub>1</sub> mm [in]
OMR 50	136.5 [5.37]	9.0 [0.35]
OMR 80	141.5 [5.57]	14.0 [0.55]
OMR 100	145.0 [5.71]	17.4 [0.69]
OMR 125	149.5 [5.89]	21.8 [0.86]
OMR 160	155.5 [6.12]	27.8 [1.09]
OMR 200	162.5 [6.40]	34.8 [1.37]
OMR 250	171.5 [6.75]	43.5 [1.71]
OMR 315	182.5 [7.19]	54.8 [2.16]
OMR 375	192.7 [7.59]	65.0 [2.56]

- C: Drain connection  
 G ¼; 15 mm [0.47 in] deep
- D: G ½; 15 mm [0.59 in] deep
- E: M8; 13 mm [0.51 in] deep  
 (4 pcs.)

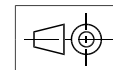
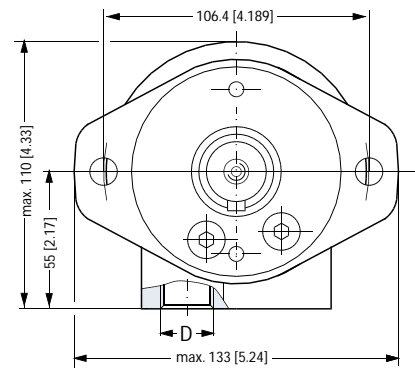
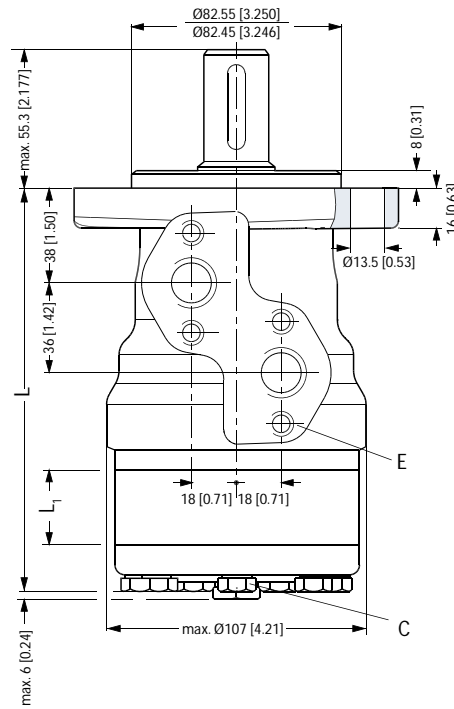

151-1845.11

**Dimensions**

OMR, OMR C and OMR N  
 Side port version with 2-hole oval mounting angle (A2 angle)

Output shaft.max.	mm L <sub>2</sub> [in]
Cylindrical shaft 32 mm [1.26 in]	68.3 [2.69]
Cylindrical shaft 25 mm [0.98 in]	55.3 [2.18]
Tapered shaft 28.56 mm [1.12 in]	56.3 [2.19]

Type	Max. L mm [in]	L <sub>1</sub> mm [in]
OMR 50	136.5 [5.37]	9.0 [0.35]
OMR 80	141.5 [5.57]	14.0 [0.55]
OMR 100	145.0 [5.71]	17.4 [0.69]
OMR 125	149.5 [5.89]	21.8 [0.86]
OMR 160	155.5 [6.12]	27.8 [1.09]
OMR 200	162.5 [6.40]	34.8 [1.37]
OMR 250	171.5 [6.75]	43.5 [1.71]
OMR 315	182.5 [7.19]	54.8 [2.16]
OMR 375	192.7 [7.59]	65.0 [2.56]

- C: Drain connection  
G ¼; 12 mm [0.47 in] deep
- D: G ½; 15 mm [0.59 in] deep
- E: M8; 13 mm [0.51 in] deep  
(4 pcs.)

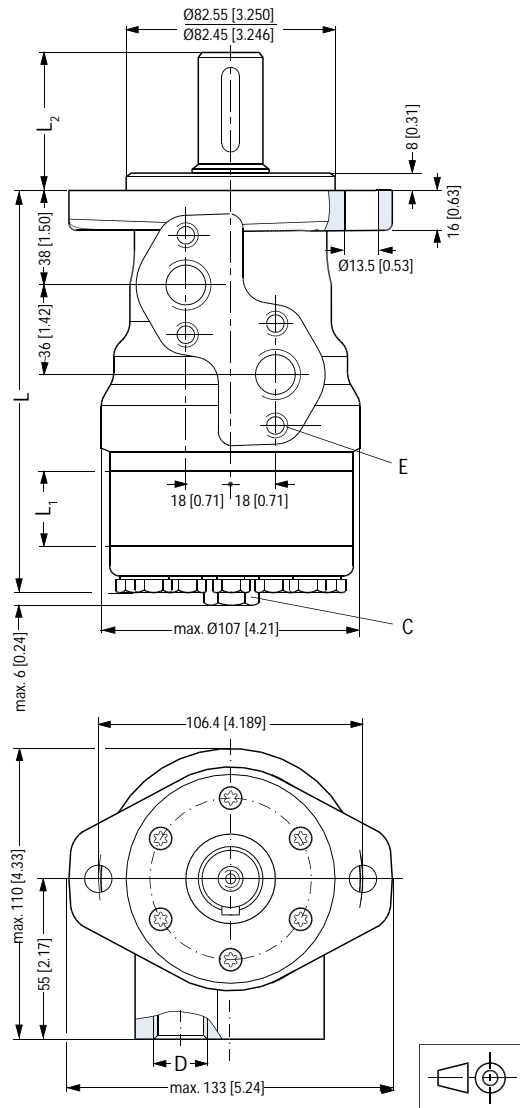

151-1849.13



Dimensions

End port version with 2-hole oval mounting angle (A2- angle)

Type	Max. L, mm [in]	L <sub>1</sub> , mm [in]
OMR 50	151.6 [5.96]	9.0 [0.35]
OMR 80	156.6 [6.17]	14.0 [0.55]
OMR 100	160.0 [6.30]	17.4 [0.69]
OMR 125	164.4 [6.47]	21.8 [0.86]
OMR 160	170.4 [6.71]	27.8 [1.09]
OMR 200	177.4 [6.98]	34.8 [1.37]
OMR 250	186.1 [7.33]	43.5 [1.71]
OMR 315	197.4 [7.77]	54.8 [2.16]
OMR 375	207.6 [8.17]	65.0 [2.56]

C: G ¼; 12 mm [0.47 in] deep  
 D: G ½; 15 mm [0.59 in] deep

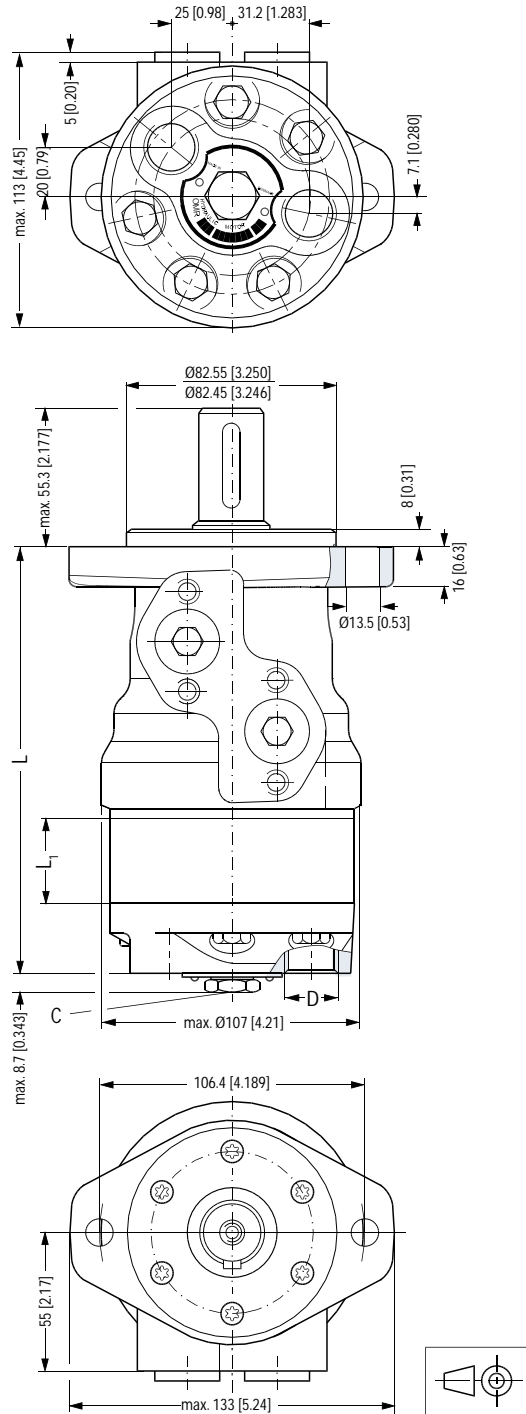

151-1752.11

**Dimensions**

*Side port version with 2-hole oval mounting flange (A2- flange)*

Type	Max. L mm [in]	L <sub>1</sub> mm [in]
OMR 50	142.5 [5.61]	9.0 [0.35]
OMR 80	147.5 [5.81]	14.0 [0.55]
OMR 100	151.0 [5.95]	17.4 [0.69]
OMR 125	155.4 [6.12]	21.8 [0.86]
OMR 160	161.5 [6.36]	27.8 [1.09]
OMR 200	168.5 [6.63]	34.8 [1.37]
OMR 250	177.5 [6.99]	43.5 [1.71]
OMR 315	188.5 [7.42]	54.8 [2.16]
OMR 375	198.5 [7.82]	64.8 [2.56]

- C: Drain connection  
 $\frac{7}{16}$ - 20 mm UNF;  
 12 mm [0.47 in] deep
- D:  $\frac{7}{8}$ - 14 UNF;  
 16.76 mm [0.66 in] deep
- E: M8; 13 mm [0.51 in] deep  
 (4-off)

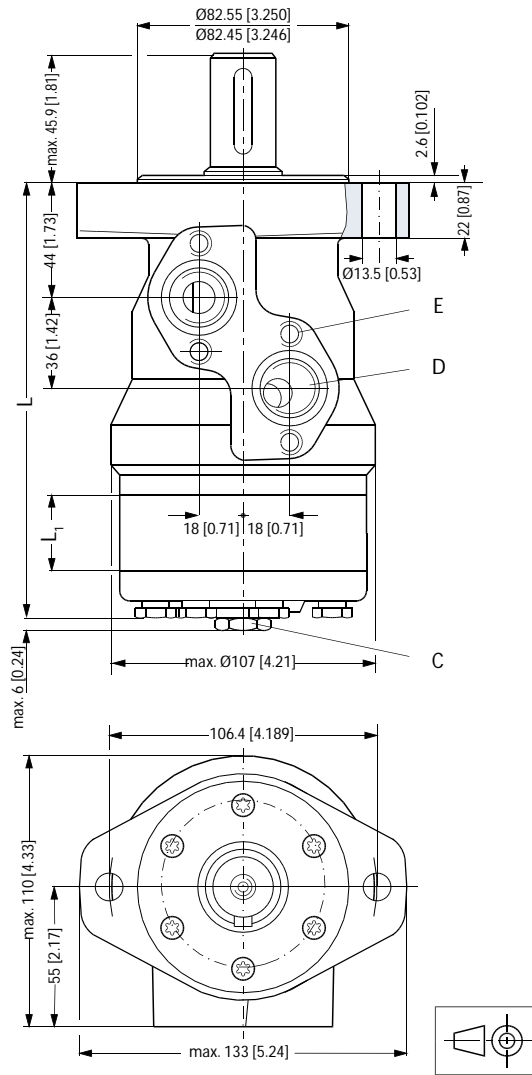

151-1223.11

Dimensions

Side port version with 4-hole oval mounting angle (A4 angle)

Output shaft.max.	mm L <sub>2</sub> [in]
Cylindrical shaft 32 mm [1.26 in]	68.3 [2.69]
Cylindrical shaft 25 mm [0.98 in]	55.3 [2.18]
Tapered shaft 28.56 mm [1.12 in]	56.3 [2.19]

Type	Max. L mm [in]	L <sub>1</sub> mm [in]
OMR 50	136.5 [5.37]	9.0 [0.35]
OMR 80	141.5 [5.57]	14.0 [0.55]
OMR 100	145.0 [5.71]	17.4 [0.69]
OMR 125	149.5 [5.89]	21.8 [0.86]
OMR 160	155.5 [6.12]	27.8 [1.09]
OMR 200	162.5 [6.40]	34.8 [1.37]
OMR 250	171.5 [6.75]	43.5 [1.71]
OMR 315	182.5 [7.19]	54.8 [2.16]
OMR 375	192.7 [7.59]	65.0 [2.56]

- C: Drain connection  
G ¼; 15 mm [0.47 in] deep
- D: G ½; 15 mm [0.59 in] deep
- E: M8; 13 mm [0.51 in] deep  
(4 pcs.)

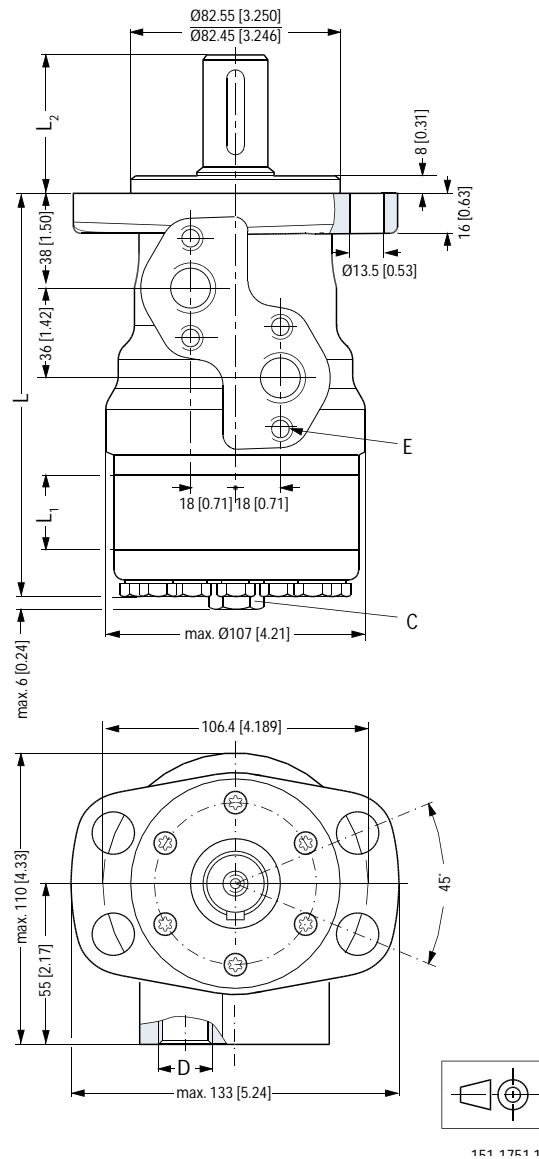

151 1751 11

Dimensions

Side port version with 4-hole oval mounting angle (A4- angle)

Type	Max. L mm [in]	L <sub>1</sub> mm [in]
OMR 50	136.5 [5.37]	9.0 [0.35]
OMR 80	141.5 [5.57]	14.0 [0.55]
OMR 100	145.0 [5.71]	17.4 [0.69]
OMR 125	149.5 [5.89]	21.8 [0.86]
OMR 160	155.5 [6.12]	27.8 [1.09]
OMR 200	162.5 [6.40]	34.8 [1.37]
OMR 250	171.5 [6.75]	43.5 [1.71]
OMR 315	182.5 [7.19]	54.8 [2.16]
OMR 375	192.7 [7.59]	65.0 [2.56]

- C: Drain connection  
 $\frac{7}{16}$ - 20 UNF;  
 12 mm [0.47 in] deep
- D:  $\frac{7}{8}$ - 14 UNF;  
 17 mm [0.66 in] deep
- E: M8; 13 mm [0.51 in] deep  
 (4-off)

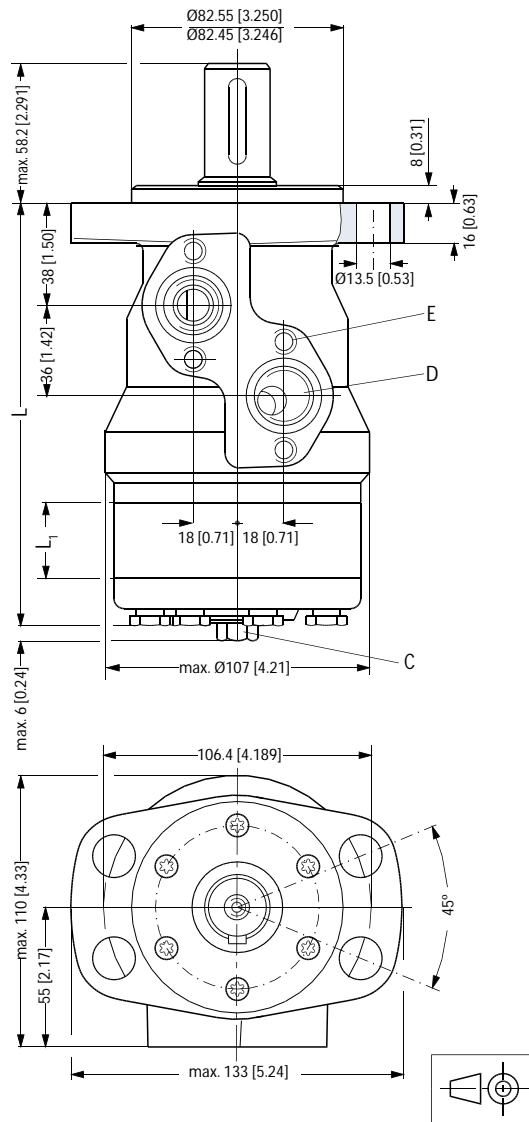

151 1221 11

Dimensions

End port version with square mounting angle (C- angle)

Type	Max. L, mm [in]	L, mm [in]
OMR 50	157.6 [6.21]	9.0 [0.35]
OMR 80	162.6 [6.40]	14.0 [0.55]
OMR 100	166.0 [6.54]	17.4 [0.69]
OMR 125	170.4 [6.71]	21.8 [0.86]
OMR 160	176.4 [6.95]	27.8 [1.09]
OMR 200	183.4 [7.22]	34.8 [1.37]
OMR 250	192.1 [7.56]	43.5 [1.71]
OMR 315	203.4 [8.02]	54.8 [2.16]
OMR 375	213.5 [8.41]	65.0 [2.56]

- C: Drain connection  
 G ¼; 12 mm [0.47 in] deep
- D: G ½; 15 mm [0.59 in] deep
- E: M10; 15 mm [0.59 in] deep  
 (4 pcs.)

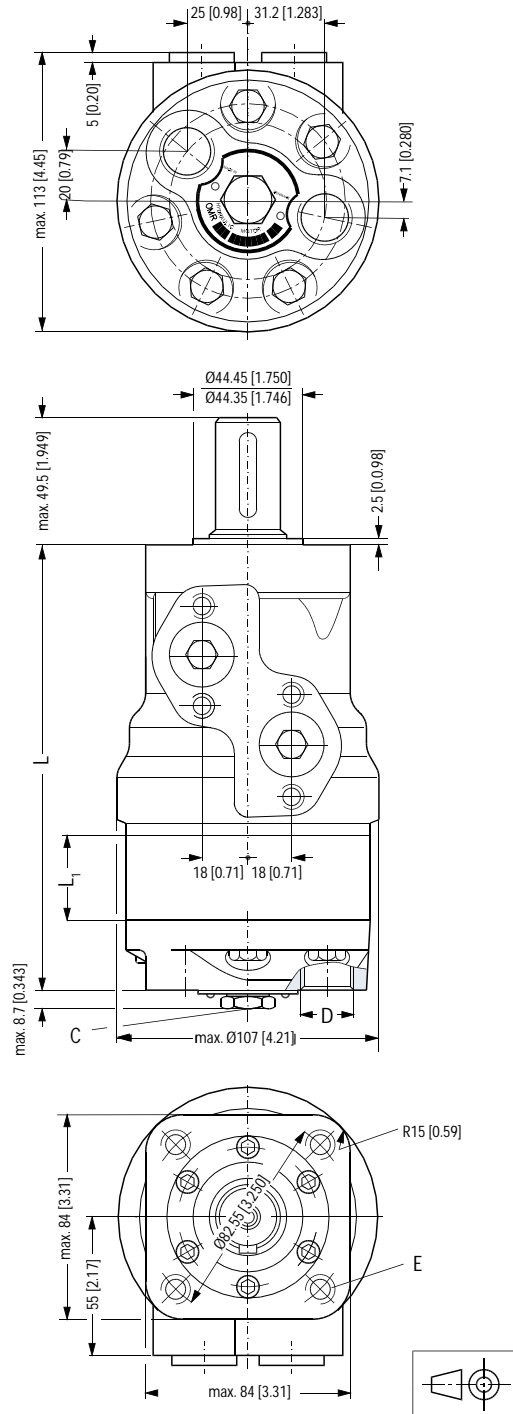

151-1753.11

Dimensions

Side port version with square mounting ange (C- ange)

Type	Max. L mm [in]	L <sub>1</sub> mm [in]
OMR 50	142.5 [5.61]	9.0 [0.35]
OMR 80	147.5 [5.81]	14.0 [0.55]
OMR 100	151.0 [5.95]	17.4 [0.69]
OMR 125	155.4 [6.12]	21.8 [0.86]
OMR 160	161.5 [6.36]	27.8 [1.09]
OMR 200	168.5 [6.63]	34.8 [1.37]
OMR 250	177.5 [6.99]	43.5 [1.71]
OMR 315	188.5 [7.42]	54.8 [2.16]
OMR 375	198.7 [7.82]	65.0 [2.56]

- C: Drain connection  
 $\frac{7}{16}$  - 20 mm UNF;  
 12 mm [0.47 in] deep
- D:  $\frac{7}{8}$  - 14 UNF;  
 17 mm [0.66 in] deep
- E: M8; 13 mm [0.51 in] deep (4-off)
- F:  $\frac{3}{8}$  - 16 UNC;  
 15 mm [0.59 in] deep (4-off)

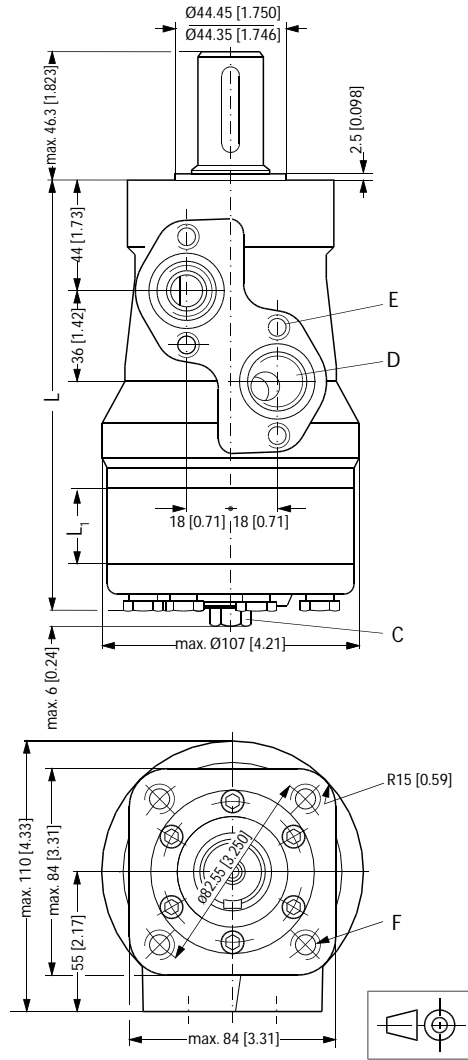

151-1220 11

Dimensions

OMRW N wheel motor

Type	Max. L mm [in]	L <sub>1</sub> mm [in]
OMRW 50 N	107.0 [4.21]	9.0 [0.35]
OMRW 80 N	112.0 [4.41]	14.0 [0.55]
OMRW 100 N	115.4 [4.54]	17.4 [0.69]
OMRW 125 N	119.8 [4.72]	21.8 [0.86]
OMRW 160 N	125.8 [4.95]	27.8 [1.09]
OMRW 200 N	132.8 [5.23]	34.8 [1.37]
OMRW 250 N	141.5 [5.57]	43.5 [1.71]
OMRW 315 N	153.0 [6.02]	54.8 [2.16]
OMRW 375 N	163.0 [6.42]	65.0 [2.56]

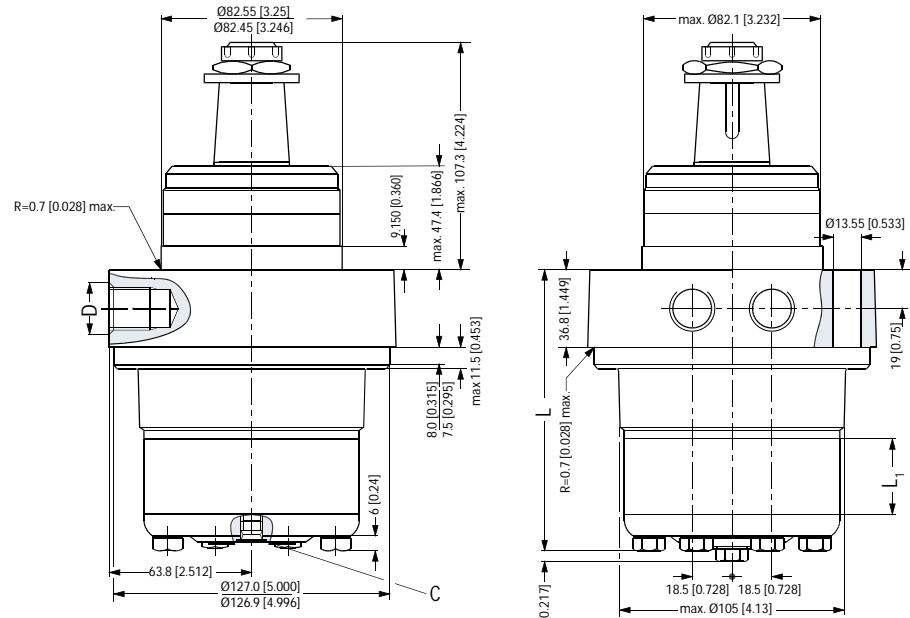

- C: Drain connection  
G ¼; 12 mm [0.47 in] deep
- D: G ½; 15 mm [0.59 in] deep

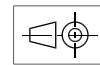
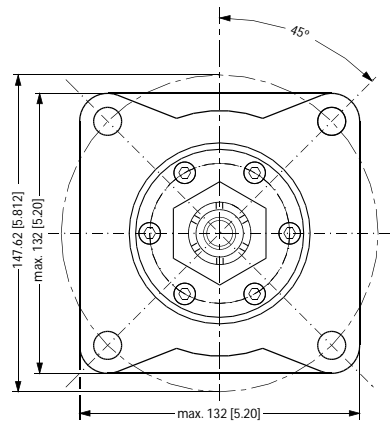

151-1386.11

Dimensions

OMRW N wheel motor

Type	Max. L mm [in]	L <sub>1</sub> mm [in]
OMRW 50 N	107.0 [4.21]	9.0 [0.35]
OMRW 80 N	112.0 [4.41]	14.0 [0.55]
OMRW 100 N	115.4 [4.54]	17.4 [0.69]
OMRW 125 N	119.8 [4.72]	21.8 [0.86]
OMRW 160 N	125.8 [4.95]	27.8 [1.09]
OMRW 200 N	132.8 [5.23]	34.8 [1.37]
OMRW 250 N	141.5 [5.57]	43.5 [1.71]
OMRW 315 N	153.0 [6.02]	54.8 [2.16]
OMRW 375 N	163.0 [6.42]	65.0 [2.56]

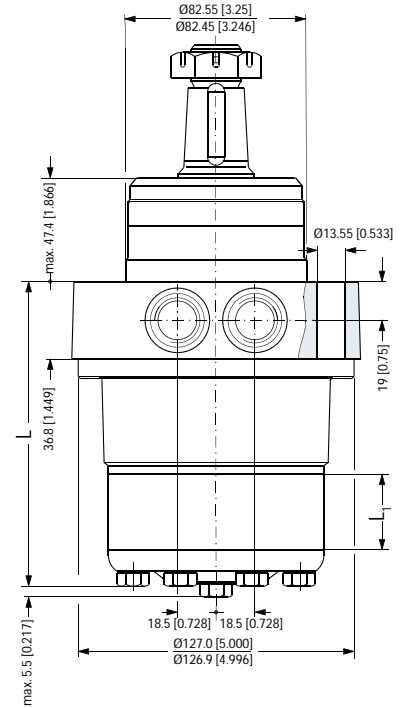
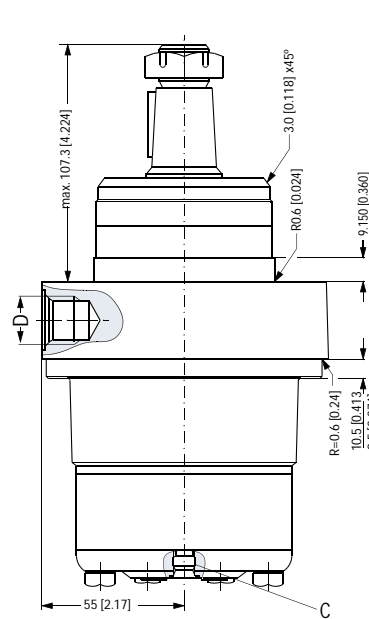

- C: Drain connection  
 $\frac{7}{16}$ - 20 UNF;  
 12 mm [0.47 in] deep
- D:  $\frac{7}{8}$ - 14 UNF;  
 17 mm [0.66 in] deep

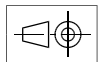
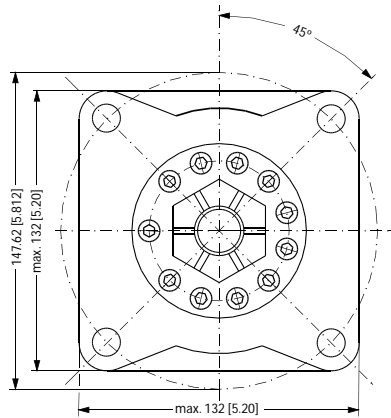

151-1625 11



**Dimensions**

*OMR F motor*

Type	Max. L mm [in]	L <sub>1</sub> mm [in]	L <sub>2</sub> mm [in]	L <sub>3</sub> mm [in]
OMR 80 F	241.3 [9.50]	14.0 [0.55]	187.3 [7.37]	210.8 [8.30]
OMR 100 F	244.7 [9.63]	17.4 [0.69]	190.7 [7.51]	214.2 [8.43]
OMR 125 F	249.1 [9.81]	21.8 [0.86]	195.1 [7.68]	218.6 [8.61]
OMR 160 F	255.1 [10.04]	27.8 [1.09]	201.1 [7.92]	224.6 [8.84]
OMR 200 F	262.1 [10.32]	34.8 [1.37]	208.1 [8.19]	231.6 [9.12]
OMR 250 F	270.8 [10.66]	43.5 [1.71]	216.8 [8.54]	240.3 [9.46]
OMR 315 F	282.1 [11.11]	54.8 [2.16]	228.1 [8.98]	251.6 [9.91]
OMR 375 F	292.3 [11.51]	65.0 [2.56]	238.3 [9.38]	261.8 [10.31]

- C: Drain connection  
 G ¼; 12 mm [0.47 in] deep
- D: G ½; 15 mm [0.59 in] deep
- E: M8; 13 mm [0.51 in] deep
- F: Brake release connection G ¼

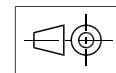
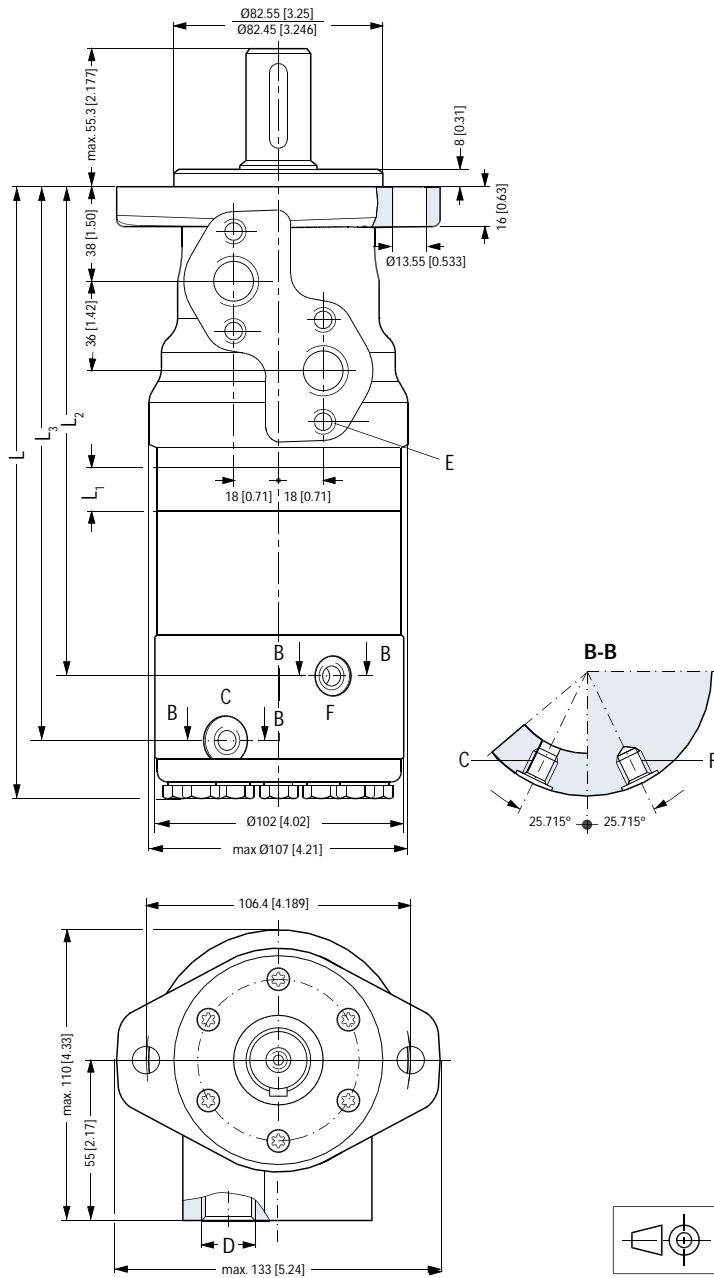

151-1719.11

Dimensions

OMR NF motor

Type	Max. L mm [in]	L <sub>1</sub> mm [in]	L <sub>2</sub> mm [in]	L <sub>3</sub> mm [in]
OMR 80 NF	247.3 [9.74]	14.0 [0.55]	193.3 [7.61]	216.8 [8.54]
OMR 100 NF	250.7 [9.87]	17.4 [0.69]	196.7 [7.74]	220.2 [8.67]
OMR 125 NF	255.1 [10.04]	21.8 [0.86]	201.1 [7.92]	224.6 [8.84]
OMR 160 NF	261.1 [10.28]	27.8 [1.09]	207.1 [8.15]	230.6 [9.08]
OMR 200 NF	268.1 [10.55]	34.8 [1.37]	214.1 [8.43]	237.6 [9.35]
OMR 250 NF	276.8 [10.90]	43.5 [1.71]	222.8 [8.77]	246.3 [9.70]
OMR 315 NF	288.1 [11.34]	54.8 [2.16]	234.1 [9.22]	257.6 [10.14]
OMR 375 NF	298.3 [11.74]	65.0 [2.56]	244.3 [9.62]	267.8 [10.54]

- C: Drain connection  
 $\frac{7}{16}$  - 20 UNF
- D:  $\frac{7}{8}$  - 14 UNF, 0.66 in (15 mm) deep
- E: M8; 0.51 in (13 mm) deep
- F: Brake release connection  $\frac{7}{16}$  - 20 UNF

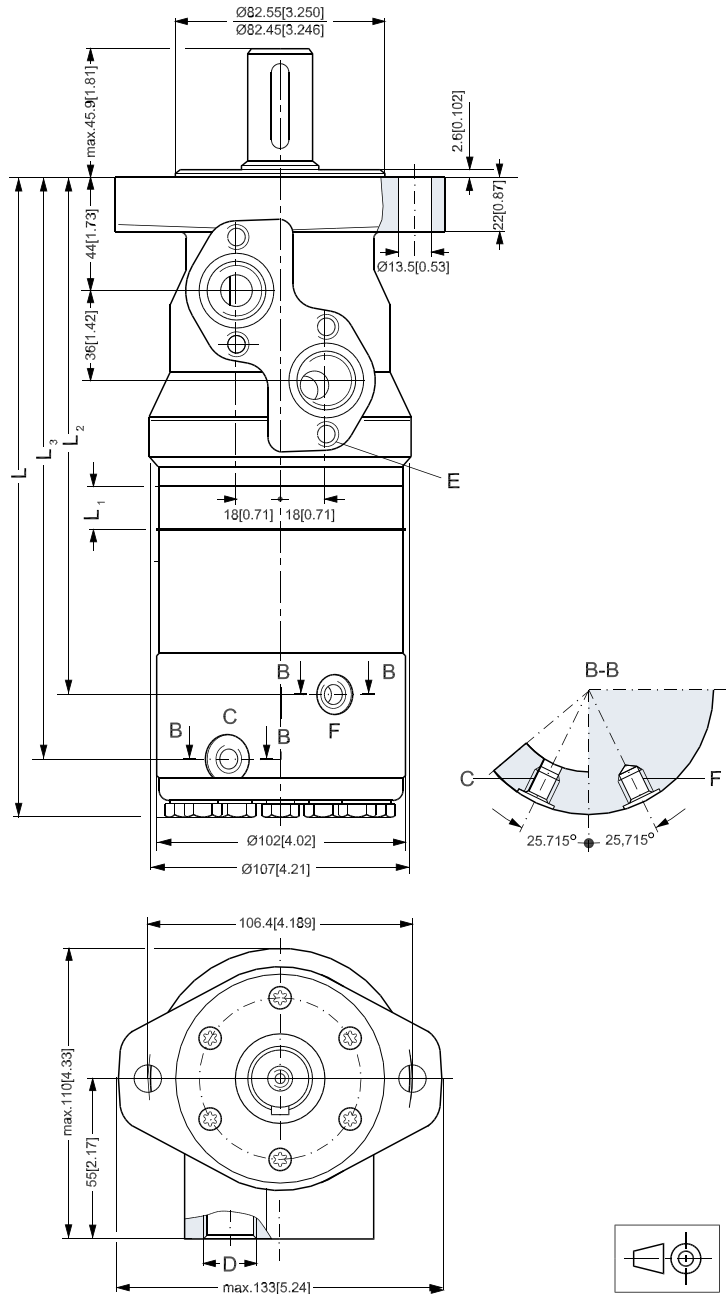

151-1719.11.22

Dimensions

OMRW NF motor

Type	Max. L mm [in]	L <sub>1</sub> mm [in]
OMRW 80 NF	213.2 [8.39]	14.0 [0.55]
OMRW 100 NF	216.6 [8.53]	17.4 [0.69]
OMRW 125 NF	221.0 [8.70]	21.8 [0.86]
OMRW 160 NF	227.0 [8.94]	27.8 [1.09]
OMRW 200 NF	234.0 [9.21]	34.8 [1.37]
OMRW 250 NF	242.7 [9.56]	43.5 [1.71]
OMRW 315 NF	254.0 [10.0]	54.8 [2.16]
OMRW 375 NF	264.2 [10.40]	65.0 [2.56]

Type	Max. L <sub>2</sub> mm [in]	L <sub>3</sub> mm [in]
OMRW 80 NF	159.2 [6.27]	182.7 [7.19]
OMRW 100 NF	162.6 [6.40]	186.1 [7.50]
OMRW 125 NF	167.0 [6.57]	190.5 [7.50]
OMRW 160 NF	173.0 [6.81]	196.5 [7.74]
OMRW 200 NF	180.0 [7.09]	203.5 [8.01]
OMRW 250 NF	188.7 [7.43]	212.2 [8.35]
OMRW 315 NF	200.0 [7.87]	223.5 [8.80]
OMRW 375 NF	210.2 [8.28]	233.7 [9.20]

- C: Drain connection  
G ¼; 12 mm [0.47 in] deep
- D: G ½; 15 mm [0.59 in] deep
- E: M8; 13 mm [0.51 in] deep
- F: Brake release connection G ¼

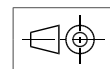
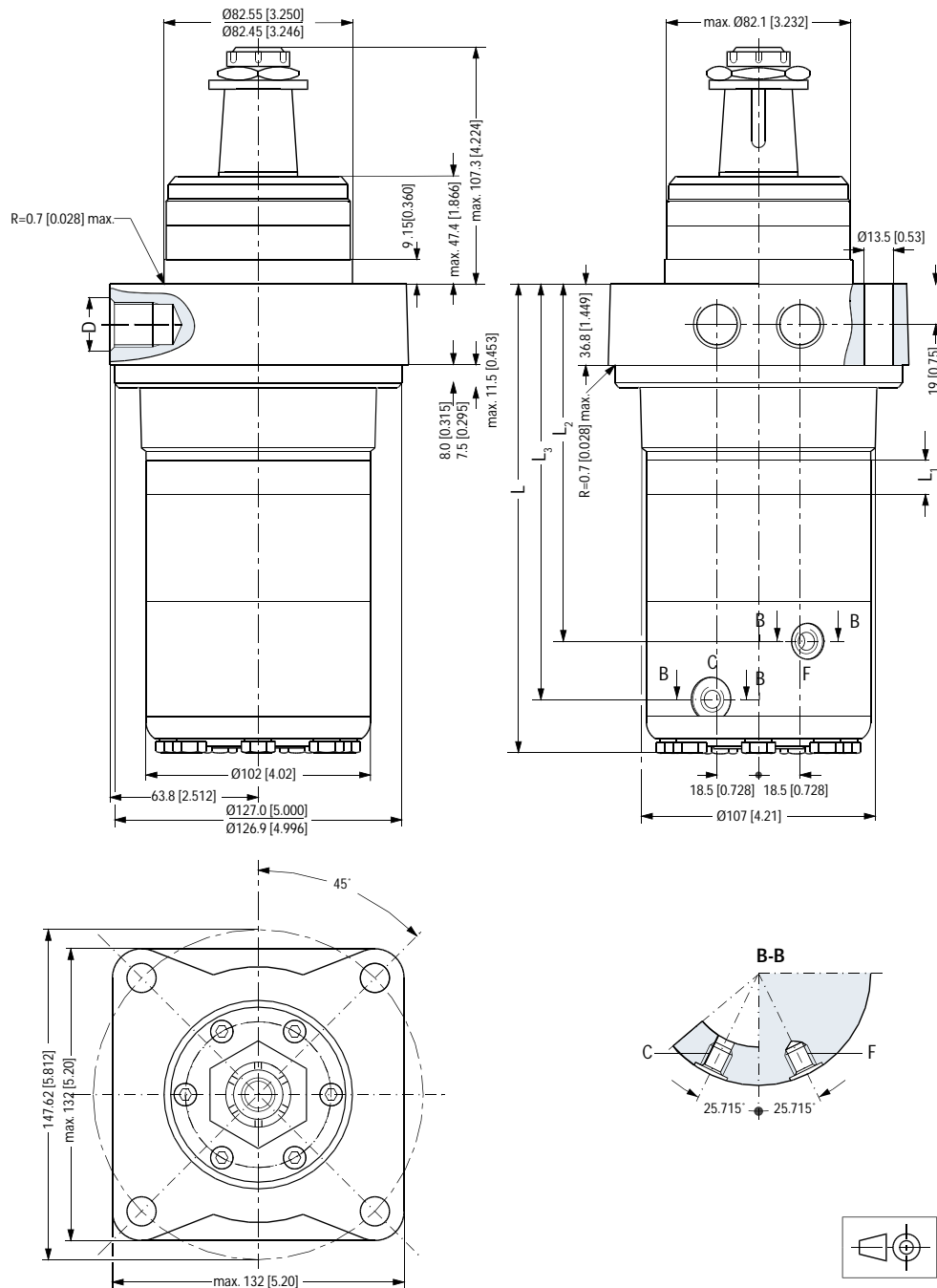

151-1793.11