

Hydraulic motor type OMRW with integrated flushing valve

HN.12.LA.02 is new



Introduction

Danfoss is introducing OMRW motors with integrated flushing valve, without modifying the outer dimensions of the motor.

Function

The integrated flushing valve is meant to ensure a continuous renewal and cooling of the oil in the closed circuit.

The flushing valve is activated by the high-pressure side of the motor. Operation of the valve turns on the flushing flow to tank via the drain connection.

The flushing valve is independent of oil viscosity.

The hydraulic motor is available with different orifice sizes i.e. with different flushing flows. Please see curves overleaf.

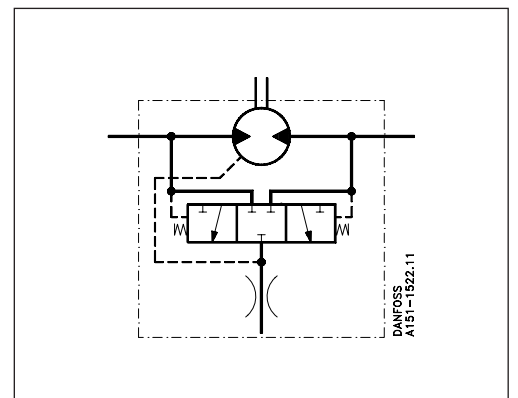

Characteristics of flushing valve

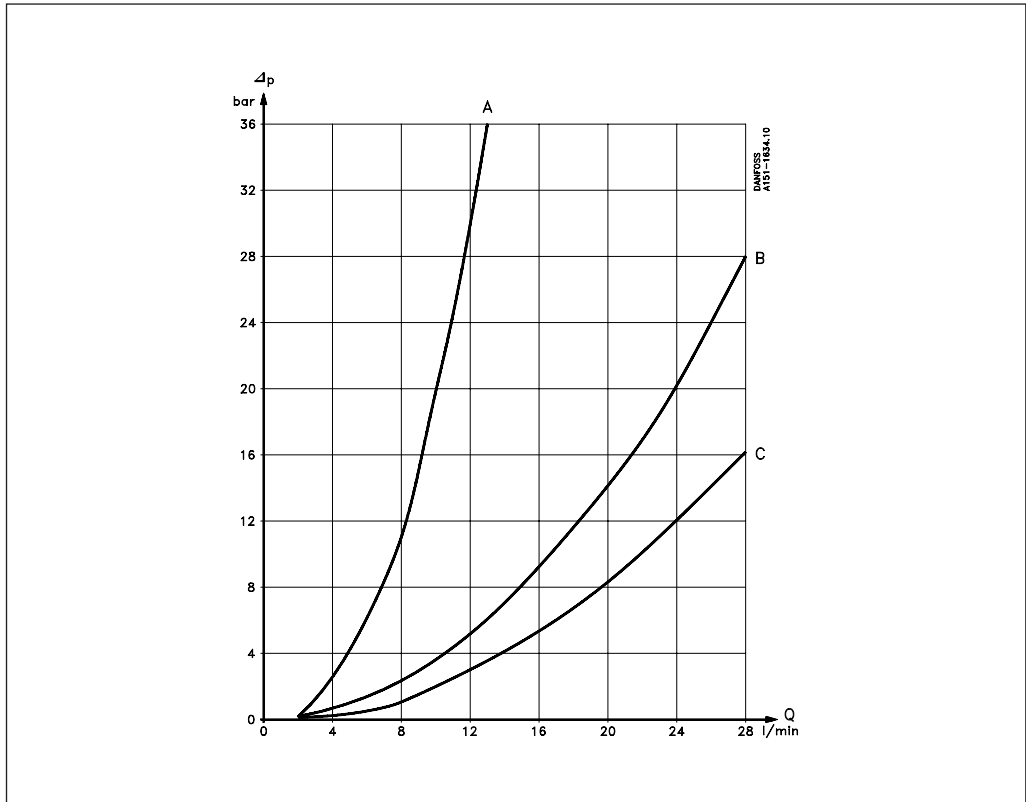

- A: Orifice size \varnothing 2 mm
- B: - \varnothing 3 mm
- C: - \varnothing 4 mm

Sectional view of flushing valve

The drawing below illustrates how the flushing valve is integrated in the motor housing of the OMRW motor.

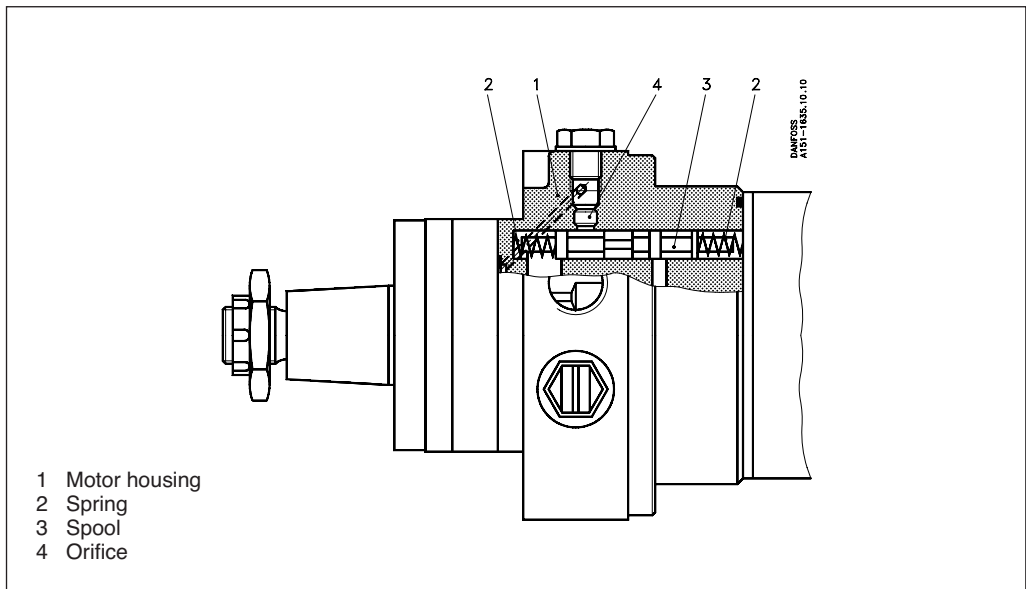

Factory 19 / 5 Lyn Parade PRESTONS NSW 2170

Ph: (02) 9607 4100 Fax: (02) 9607 4200