

D Series

Cast Iron Gear Pumps

Technical Information

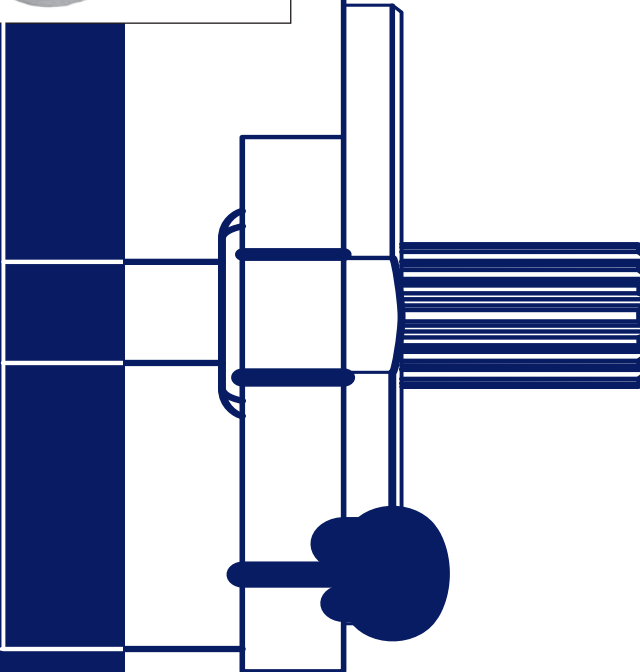
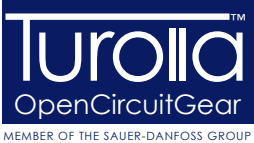

History of Revisions

Table of Revisions

Date	Page	Changed	Rev.
Jun, 2010	-	First edition	A
December 2010	all	Major update	B
April 2011	all	Major update	C
October 2011	all	Major update: Model code section, cover, images p. 53	D

© 2011 Turolla OpenCircuitGearTM. All rights reserved.

TurollaOCG accepts no responsibility for possible errors in catalogs, brochures and other printed material. TurollaOCG reserves the right to alter its products without prior notice. This also applies to products already ordered provided that such alterations can be made without affecting agreed specifications. All trademarks in this material are properties of their respective owners. Sauer-Danfoss, Turolla, Turolla OpenCircuitGear, TurollaOCG, OpenCircuitGear, Fast Lane and PLUS+1 are trademarks of the Sauer-Danfoss Group.

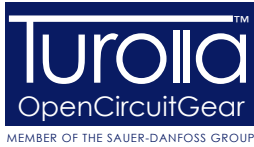

D Series Cast Iron Gear Pumps

Technical Information

Contents

General information	Overview	4
	Features and Benefits.....	4
	Quick Reference Chart.....	4
	Construction	5
	System Schematic	6
	Typical Applications	7
	Product Features.....	7
Technical Specifications	Technical Specifications	8
Operating Parameters	Sizing Equations	9
	Pressure.....	10
	Temperature and Viscosity.....	11
	Speed	11
	Hydraulic Fluid	12
	Filtration.....	12
	Reservoir	13
	Line Sizing	13
	Pump Life	13
	Pump Shaft Connection.....	14
	Radial and Axial Loading	14
Model Code	Single Pump Order Code.....	15
	Two Section (Tandem) Pump Order Code.....	23
	Three Section (Triple) Pump Order Code.....	30
	Four Section (Quad) Pump Order Code	36
Options	Shaft Options	43
	Mounting Flanges	46
	Multiple Pump Port Options	49
	Rear Cover - Port Options, Integrates Valves and Auxiliary Flange	50
Dimension Drawings	Dimensions.....	59
Performance Data	Flow performance	63
Reference Literature	TurollaOCG Literature	68

D Series Cast Iron Gear Pumps

Technical Information

General Information

Overview

The D Series fixed displacement gear pump has been specifically designed for demanding mobile equipment applications where maximum performance is required at peak power levels and operating temperatures. The design integrates cast iron construction with pressure balanced thrust plates to deliver consistent efficiency across the entire operating range of pressure, speed, and temperature; all in an industry-leading package size that maximizes power density. For technical information on D Series motors, refer to *D Series Hydraulic Gear Motors Technical Information 11044656*.

Features and Benefits

- High strength cast iron construction allows consistently efficient performance and long life in continuous operation at 276 bar [4000 psi] and peak conditions of 303 bar [4400 psi].
- Custom engineered bearings, pressure-balanced load plates, and viton seals optimize internal lubrication allowing for long life with intermittent fluid temperatures up to 115 °C [239 °F] and fluid viscosities as low as 8 mm²/sec (cSt) [36 SUS].
- Compact three-piece design maximizes power density and creates one of the shortest multi-section pumps (with up to four pumping sections) in the global marketplace.
- Bearings located in the front flange increase radial/axial load carrying capability and eliminate the need for most bolt-on outrigger bearings.

Quick Reference Chart

The D pump blends the traditional Group 2 (SAE-A) and Group 3 (SAE-B) frame sizes in a single package with displacements from 7 cc to 45 cc [0.43 in³ to 2.75 in³]. These displacements, in addition to a wide variety of shafts, flanges, ports, and integrated valve options can be used in virtually any combination to offer greater design flexibility and meet specific application requirements.

TurollaOCG Gear Pumps

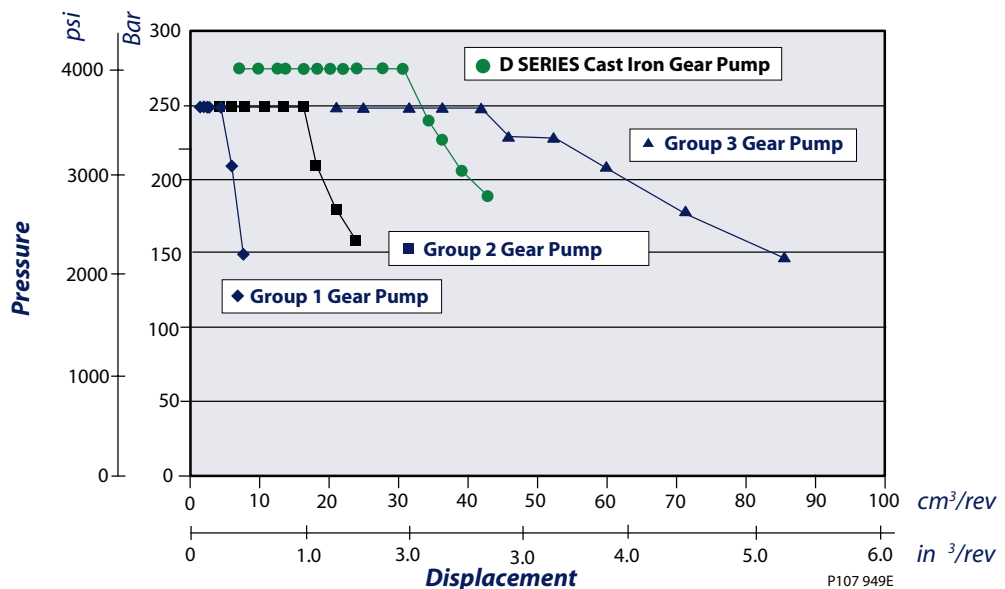

D Series Cast Iron Gear Pumps

Technical Information

General Information

Construction

Quality components and construction

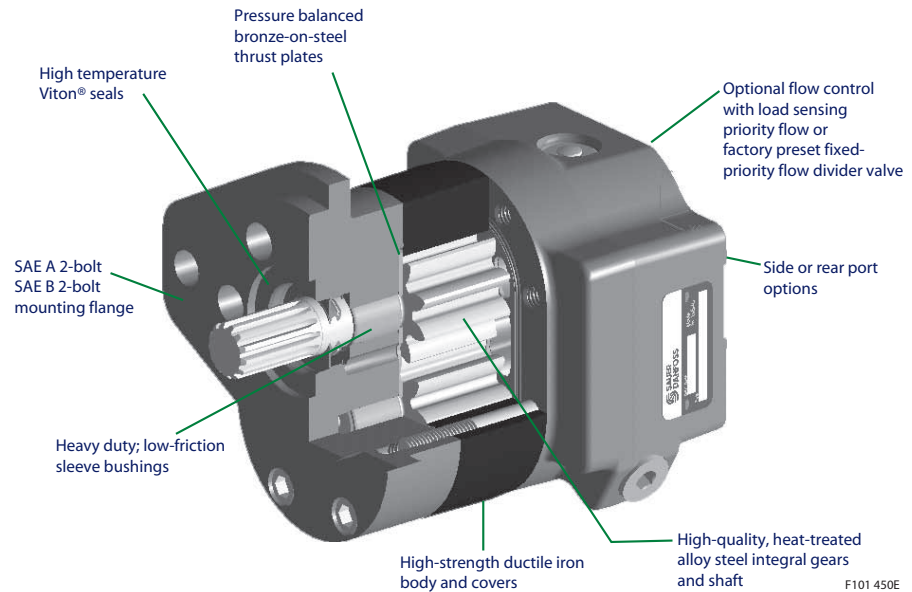

Cast Iron Housings and Bearings

The three piece structural members of the pump are made of high-strength cast ductile iron. Cast iron provides contamination resistance, thermal stability and the strength needed for consistently high levels of performance and durability needed in demanding off highway applications.

Heavy duty, low friction, PTFE-lined sleeve bushings have been optimized to provide long life in low viscosity, high pressure conditions. The bearings are located in the front mounting flange, rear cover, and bearing plate (for multiple section pumps) and allow the D pump to be 20% shorter than a typical bearing block design pump. In addition, the proximity of the front bearing to the mounting flange increases the radial load capacity of the pump, eliminating the need for most bolt-on outrigger requirements.

Pressure Balance and Sealing

The pump incorporates two steel-backed bronze thrust plates seated in depressions in the mounting flange, rear cover, and bearing plate (for multiple section pumps). Underneath the front plate (known as the deflecting plate) is the load seal.

The “E” shaped load seal distributes system pressure underneath the plate and enables the plate to deflect and maintain a tight sealing surface against the side face of the gears.

The tight sealing action allows the pump to maintain very high levels of volumetric efficiency, even when operating in extreme temperature, pressure and speed conditions.

D Series Cast Iron Gear Pumps

Technical Information

General Information

Construction (continued)

One Piece Gear Construction

All D Series pump gear shafts are of one-piece construction. This enables the shaft to provide uniform high strength and accurate gear profile relative to the journals for smooth mesh operation. The integral gear shafts are constructed of heat treated AISI 8620 steel, manufactured to precise tolerances and surface finishes, for maximal life and minimal leakage. This integral design eliminates the potential problems of fatigue stress and gear face mismatch often associated with two-piece gear shaft designs.

Multiple Pump Configuration

D Series pumps can be coupled together to produce tandem, triple and even quadruple section units. The interconnecting chambers accommodate fluid flow between sections and allow the number of inlet connections to be minimized. Systems that require operation with different fluids and/or reservoirs can be accommodated with sealed auxiliary covers between sections.

System Schematic

Gear Pump/Gear Motor Fan Drive System with Electronic Control

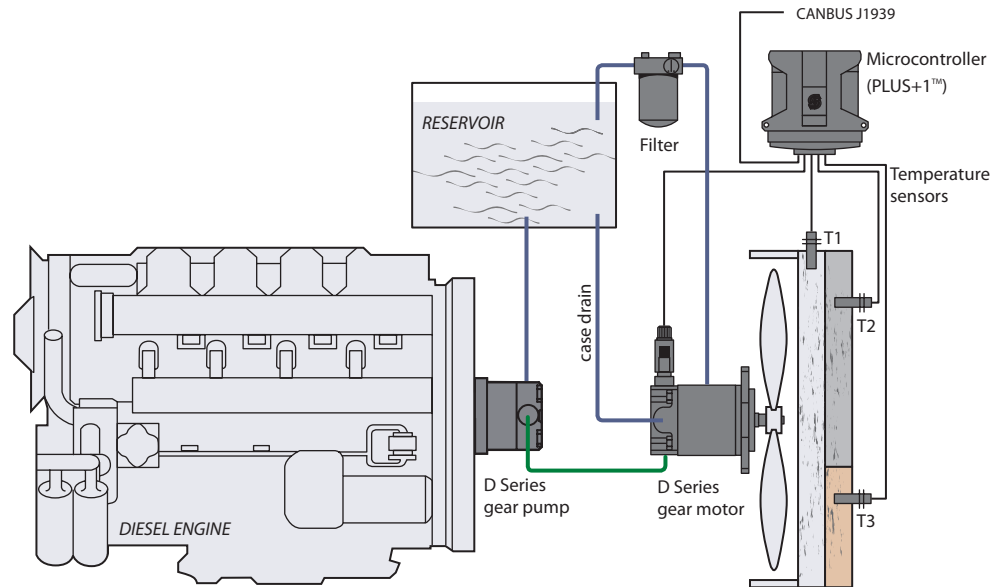

P107 929E

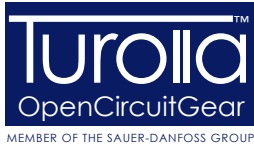

D Series Cast Iron Gear Pumps

Technical Information

General Information

Typical Applications

The D Series gear pump is commonly applied in the following type of applications:

- Wheel loader - Aggressive duty cycles with continuous working pressures above 250 bar [3600 psi]
- Mining equipment - Increased exposure to system contamination in a corrosive environment
- Skid steer loaders - Multiple pump combinations with short length and common inlets
- Work function attachments - Rapid loading of cylinders/motors in high bulk modulus systems causing pressure rise rates greater than 3000 bar/sec
- Agricultural sprayers - Pumps with integrated valves including priority flow dividers and load sense steering
- Pavers - D pumps integrated with other TurolloOCG components including variable displacement piston pumps, aluminum gear pumps and cartridge valves
- Fan drives - High levels of performance with elevated temperatures and minimal oil viscosities and restrictive envelope dimensions

Product Features

Features	Description
Construction	Heavy duty ductile iron 3-piece construction with pressure balance load plates and viton seals
Displacements	7 to 45 cm ³ [0.43 to 2.75 in ³ /rev]
Continuous Pressure	276 bar [4000 psi] up to 32 cm ³ [1.94 in ³ /rev]
Peak Pressure	303 bar [4400 psi] up to 32 cm ³ [1.94 in ³ /rev]
Speed	600 to 3400 min ⁻¹ (rpm) - up to 25cm ³ [1.55 in ³ /rev]
Mounting	SAE A two bolt, SAE B two bolt, Perkins engine mount
Shaft (types)	Straight keyed, 1:8 tapered keyed, 9T, 11T, 13T and 15T splined
Ports	SAE O-ring boss, SAE split flange, beaded tube inlet (axial and radial)
Fluid viscosity*	8 mm ² /sec (cSt) [36 SUS] minimum, 1600 mm ² /sec (cSt) [7500 SUS] maximum
Filtration requirement	22/18/13 ISO 4406 at motor inlet
Fluids	Petroleum/mineral based
Operating temperature*	-40°C [-40°F] minimum for cold start 110°C [230°F] normal operating conditions 115°C [239°F] peak intermittent
Configurations	Single, tandem, triple, and quadruple multisection pumps available with common inlets. Integrated auxiliary cover for through drive applications.
Integrated valve options	Priority flow divider with priority relief Priority steering with steering relief Load sense priority flow divider

* Temperature and viscosity requirements must be satisfied concurrently.

Technical Specifications

Ratings	Units	07	10	11	13	14	17	19	21	23	25	29	32	36	38	41	45
Displacement	cm ³ /rev	7.0	9.5	10.8	12.6	14.3	17.0	19.0	20.5	22.5	25.4	29.0	31.8	36.1	38.0	41.0	45.1
	in ³ /rev	0.43	0.58	0.66	0.77	0.87	1.04	1.16	1.25	1.37	1.55	1.77	1.94	2.20	2.32	2.50	2.75
Rated pressure	bar	276	276	276	276	276	276	276	276	276	276	276	276	241	228	207	190
	psi	4000	4000	4000	4000	4000	4000	4000	4000	4000	4000	4000	4000	3500	3300	3000	2750
Peak pressure	bar	303	303	303	303	303	303	303	303	303	303	303	303	265	250	228	209
	psi	4400	4400	4400	4400	4400	4400	4400	4400	4400	4400	4400	4400	3850	3630	3300	3025
Speed min ⁻¹ (rpm)	maximum	3400	3400	3400	3400	3400	3400	3400	3400	3400	3400	3200	3000	2750	2750	2500	2500
	minimum*	1200	900	900	700	700	600	600	600	600	600	600	600	600	600	600	600
Theoretical flow at max speed	l/min	24.0	32.3	36.7	42.9	48.5	57.9	64.6	69.6	76.3	86.4	92.8	95.4	99.0	104.5	102.4	112.7
	US gal/min	6.3	8.5	9.7	11.3	12.8	15.3	17.1	18.4	20.2	22.8	24.5	25.2	26.2	27.6	27.1	29.8
Weight	kg	7.2	7.3	7.4	7.5	7.6	7.8	7.9	7.9	8.1	8.3	8.4	8.6	8.8	9.0	9.1	9.4
	lb	15.8	16.1	16.3	16.5	16.7	17.1	17.4	17.5	17.8	18.2	18.6	19.0	19.6	19.8	20.2	20.7
Mass moment of inertia	x10 ⁻⁶ kg·m ²	60	71	77	85	92	104	105	119	128	141	157	170	188	197	218	228
	x10 ⁻⁶ slug·ft ²	44	53	57	63	68	77	77	88	95	104	116	125	139	145	155	168

* minimum speed at maximum pressure

Fluid Specifications

Parameter	Unit	Minimum	Continuous	Maximum
Viscosity*	mm ² /sec (cSt) [SUS]	8 [36]	10 - 100 [50 - 212]	1600 [7500]
Temperature*	°C [°F]	-40 [-40]	110 [230]	115 [239]
Cleanliness		ISO 4406 Class 22/18/13 or better		
Filtration efficiency, charge filtration		$\beta_{15-20}=75$ ($\beta_{10} \geq 10$)		

* Temperature and viscosity requirements must be satisfied concurrently.

Ratings are based on operation with premium petroleum-based hydraulic fluids containing oxidation, rust, and foam inhibitors.

Inlet Pressure

Maximum continuous vacuum	bar absolute [inches mercury vacuum]	0.8 [6.3]
Maximum intermittent vacuum		0.6 [12.2]
Maximum charged inlet pressure	bar [psi]	3.0 [44]

Sizing Equations

Use these formulas to determine the nominal motor size for a specific application.

Based on SI units

Input flow $Q = \frac{V_g \cdot n}{1000 \cdot \eta_v}$ (l/min)

Output torque $M = \frac{V_g \cdot \Delta p \cdot \eta_m}{20 \cdot \pi}$ (N·m)

Output power $P = \frac{M \cdot n}{9550} = \frac{Q \cdot \Delta p \cdot \eta_t}{600}$ (kW)

Motor speed $n = \frac{Q \cdot 1000 \cdot \eta_v}{V_g}$ (min⁻¹(rpm))

Based on US units

$Q = \frac{V_g \cdot n}{231 \cdot \eta_v}$ (US gal/min)

$M = \frac{V_g \cdot \Delta p \cdot \eta_m}{2 \cdot \pi}$ (lbf·in)

$P = \frac{Q \cdot \Delta p \cdot \eta_t}{1714} = \frac{M \cdot n}{63\,025}$ (hp)

$n = \frac{Q \cdot 231 \cdot \eta_v}{V_g}$ (min⁻¹(rpm))

Variables SI units [US units]

V_g	= Displacement per revolution	cm ³ /rev [in ³ /rev]
p_o	= Outlet pressure	bar [psi]
p_i	= Inlet pressure	bar [psi]
Δp	= $p_o - p_i$ (system pressure)	bar [psi]
n	= Speed	min ⁻¹ (rpm)
η_v	= Volumetric efficiency	
η_m	= Mechanical efficiency	
η_t	= Overall efficiency ($\eta_v \cdot \eta_m$)	

D Series Cast Iron Gear Pumps Technical Information Operating Parameters

Pressure

Definitions of the D Series operating parameters appear below. Consult TuroliaOCG technical support for applications running outside of these parameters.

Peak Pressure

Peak pressure is the highest intermittent pressure allowed. The relief valve overshoot (reaction time) determines peak pressure. It is assumed to occur for less than 100 ms. The illustration to the right shows peak pressure in relation to rated pressure and reaction time (100 ms maximum).

Rated Pressure

Rated pressure is the average, regularly occurring operating outlet pressure that should yield satisfactory product life. The maximum machine load demand determines rated pressure. For all systems, the load should move below this pressure.

Pressure vs. Time

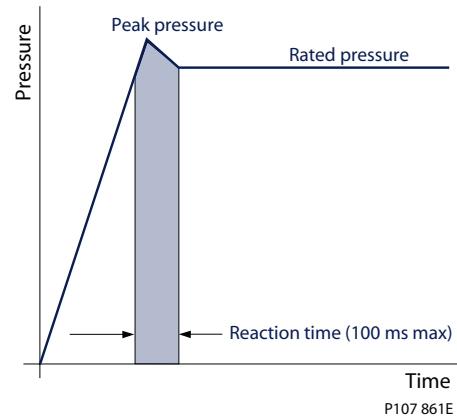

System Pressure

System pressure is the differential between the inlet and outlet ports. It is a dominant operating variable affecting hydraulic unit life. High system pressure reduces expected pump life. System pressure must remain at, or below, rated pressure during normal operation to achieve expected life.

Inlet Vacuum

Inlet vacuum must be controlled in order to realize expected performance and pump life. System design must meet inlet vacuum requirements during all modes of operation. Expect lower inlet vacuums during cold start situations. Low vacuum condition should improve quickly as fluid warms.

Pressure Rise Rate

The maximum pressure rise rate is the rate of increase in system pressure as measured at the outlet port of the pump. High pressure rise rates are commonly seen on work function applications during motor start-up, completion of cylinder stroke, and during rapid shifting of control valves. The maximum pressure rise rate of the D pump is 11,720 bar/sec [170,000 psi/sec]. During rapid rise rate situations, the system pressure must not exceed the rated pressure of the pump.

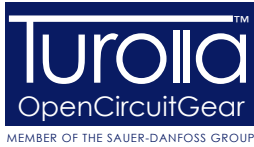

D Series Cast Iron Gear Pumps

Technical Information

Operating Parameters

Temperature and Viscosity

Temperature

High temperature limits apply at the inlet port of the pump. The pump should run at or below the maximum continuous temperature.

Minimum (cold start) temperature relates to the physical properties of component materials.

Cold oil, generally, doesn't affect the durability of pump components. It may affect the ability of oil to flow and transmit power. For this reason, keep the temperature at 16°C [60 °F] above the pour point of the hydraulic fluid.

Continuous temperature is the temperature at or below the temperature which normal pump life can be expected.

Maximum temperature is the highest temperature that is tolerable by the machine for a transient/limited time (duty cycle 1% or less). At maximum temperature, oil viscosity must not go lower than minimum recommended viscosity.

Viscosity

Continuous viscosity: Recommended viscosity range for maximum efficiency and pump life.

Minimum viscosity occurs only during brief occasions of maximum fluid temperature and severe duty cycle operation. It's the minimum acceptable viscosity to guarantee the pump life. (Duty cycle 1% or less)

Maximum viscosity occurs only during cold start at very low temperatures. It is the upper limit of viscosity that allows the pump to start. During this condition, limit speeds until the system warms up.

Temperature and viscosity requirements must be concurrently satisfied.

Speed

Maximum speed is the limit recommended for operation at rated pressure. It is the highest speed at which normal life can be expected.

The lower limit of operating speed is the **minimum speed**.

Hydraulic Fluid

Ratings and data for gear pumps are based on operation with premium hydraulic fluids containing oxidation, rust, and foam inhibitors. These fluids must possess good thermal and hydrolytic stability to prevent wear, erosion, and corrosion of internal components.

Use only clean fluid in the pump and hydraulic circuit.

ⓘ Caution

Never mix hydraulic fluids.

For more information on hydraulic fluid selection, see TurollaOCG publications *Hydraulic Fluids and Lubricants, Technical Information L1021414*, and *Experience with Biodegradable Hydraulic Fluids, Technical Information L1021903*.

Filtration

Filters

Use a filter that conforms to Class 22/18/13 of ISO 4406 (or better). It may be on the pump outlet (discharge filtration) or inlet (pressure filtration).

Selecting a Filter

When selecting a filter, please consider:

- contaminant ingress rate (determined by factors such as the number of actuators used in the system)
- generation of contaminants in the system
- required fluid cleanliness
- desired maintenance interval
- filtration requirements of other system components

Measure filter efficiency with a Beta ratio (β_x):

- for discharge filtration with controlled reservoir ingress, use a $\beta_{35-45} = 75$ filter
- for pressure filtration, use a filtration with an efficiency of $\beta_{10} = 75$

β_x ratio is a measure of filter efficiency defined by ISO 4572. It is the ratio of the number of particles greater than a given diameter ("x" in microns) upstream of the filter to the number of these particles downstream of the filter.

Every system is unique. Only a thorough testing and evaluation program can fully validate the filtration system. For more information, see TurollaOCG publication, *Design Guidelines for Hydraulic Fluid Cleanliness 520L0467*.

Fluid cleanliness level and β_x ratio

Fluid cleanliness level (per ISO 4406)	Class 22/18/13 or better
β_x ratio (discharge filtration)	$\beta_{35-45} = 75$ and $\beta_{10} = 2$
$\beta_{35-45} = 75$ and $\beta_{10} = 2$	$\beta_{10} = 75$
Recommended inlet screen size	100 – 125 μm [0.0039 – 0.0049 in]

D Series Cast Iron Gear Pumps

Technical Information

Operating Parameters

Reservoir

The **reservoir** provides clean fluid, dissipates heat, removes entrained air, and allows for fluid volume changes associated with fluid expansion and during all system operating modes. A correctly sized reservoir accommodates maximum volume changes during all system operating modes. It promotes de-aeration of the fluid as it passes through, and accommodates a fluid dwell-time between 60 and 180 seconds, allowing entrained air to escape.

Minimum reservoir capacity depends on the volume required to cool and hold the oil, allowing for expansion due to temperature changes. A fluid volume of one to three times the pump output flow (per minute) is satisfactory. The minimum recommended reservoir capacity is 125% of the fluid volume.

Put the return-line below the lowest expected fluid level to allow discharge into the reservoir for maximum dwell and efficient de-aeration. A baffle (or baffles) between the return and suction lines promotes de-aeration and accommodates fluid surges.

Line Sizing

Choose line sizes that accommodate maximum fluid velocity to reduce system noise, pressure drops, and overheating in order to maximize system life and performance. Line velocities shown in the following table provide a general rule of thumb. Final selection of line sizing and fittings must comply with all pressure ratings.

Maximum line velocity

Inlet	m/sec [ft/sec]	2.4-4.3 [8-14]
Outlet		6-9 [20-30]

Most systems use hydraulic oil containing 10% dissolved air by volume. Over-aeration, or entrained air is the result of flow line restrictions, where the dissolved air comes out of solution, or when air is allowed to leak into the hydraulic circuit. These include inadequate pipe sizes, sharp bends, or elbow fittings, causing reduction of flow-line cross-sectional area. This problem will not occur if these circuit recommendations are followed, rated speed requirements are maintained, and reservoir size and location are adequate.

Pump Life

Pump life is a function of speed, system pressure, and other system parameters (such as fluid quality and cleanliness).

All TurollaOCG gear pumps use hydrodynamic journal bearings with an oil film between the gear/shaft and bearing surfaces. If the oil film is sufficiently sustained through proper system maintenance and operating within recommended limits, long life can be expected.

β_{10} life expectancy number is generally associated with rolling element bearings. It does not exist for hydrodynamic bearings.

When submitting an application for review, provide machine duty cycle data including percentage of time at various loads and speeds. We strongly recommend a prototype testing program to verify operating parameters and their impact on life expectancy before finalizing any system design.

D Series Cast Iron Gear Pumps

Technical Information

Operating Parameters

Pump Shaft Connection

Shaft options for gear pumps include tapered, splined or parallel shafts.

Plug-in drives, with a splined shaft, can impose severe radial loads when the mating spline is rigidly supported. Increasing spline clearance does not alleviate this condition.

Use plug-in drives if the concentricity between the mating spline and pilot diameter is within 0.1 mm [0.004 in]. Lubricate the drive by flooding it with oil. A three-piece coupling minimizes radial or thrust shaft loads.

Pump Shaft Connection

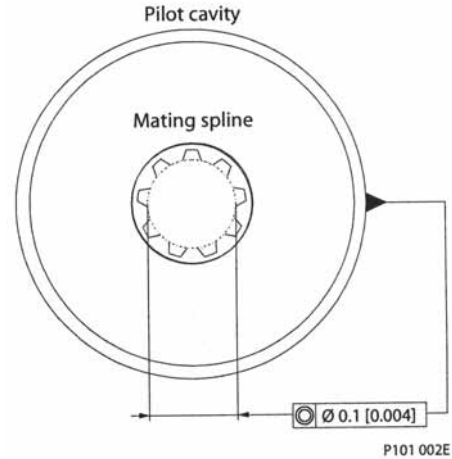

Lubricate all shaft couplings. Failure to do so will result in premature shaft failure.

⚠ Caution

To avoid spline shaft damages, use carburized and hardened steel couplings with 80-82 HRA surface hardness.

Radial and Axial Loading

Allowable radial shaft loads are a function of the load position, load orientation, and operating pressure. All external shaft loads have an effect on bearing life, and may affect pump performance.

In applications where external shaft loads cannot be avoided, minimize the impact on the pump by optimizing the orientation and magnitude of the load. Use tapered input shafts for applications with radial shaft loads. The table below shows the preferred orientation for radial loads assuming maximum pressure. For assistance concerning shaft loading, contact your TurollaOCG representative.

Maximum radial and axial loads

Ratings	Units	7	10	11	13	14	17	19	21	23	25	29	32	36	38	41	45
Maximum radial load	lbf	1430	1430	1430	1430	1430	1430	1360	1300	1210	1070	870	700	420	270	450	620
	N	6361	6361	6361	6361	6361	6361	5943	1783	5382	4760	3870	3114	1868	1201	2002	2758
Push/Pull axial load	lbf	350	350	350	350	350	350	350	350	350	350	350	350	350	350	350	350
	N	1557	1557	1557	1557	1557	1557	1557	1557	1557	1557	1557	1557	1557	1557	1557	1557

Shaft loading

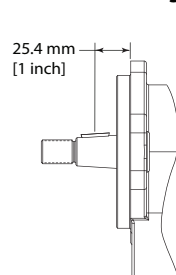

Recommended loading position

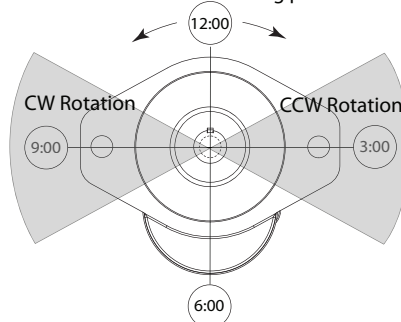

- All values measured 25.4 mm [1 inch] from the mounting flange
- For other orientations and distances, higher radial loads at lower pressures contact your S-D representative

D Series Cast Iron Gear Pumps

Technical Information

Model Code

Single Pump Order Code

Example

The order code below provides an example of a single section pump with integrated priority flow divider

A
B1 B2
C
D
E
F
G
H
J

DE1R
21SH
AC
F09A
15X
172
CZ
AN
NNN

Code	Position	Description
DE1R	A	D Series pump, single section, right hand rotation
21	B1	21 cm ³ displacement
SH	B2	13 tooth spline input shaft
AC	C	SAE A two bolt mounting flange
F09A	D	Integrated priority flow divider with cartridge style priority relief, 1 5/16-12 side inlet, 3/14-16 side priority, 7/8-14 side secondary
15X	E	15.1 l/min[4 US gal/min] priority flow setting
172	F	172 bar [2495 psi] priority relief setting
CZ	G	Assembly screws
AN	H	Standard Nameplate
NNN	J	No special features, black paint

DE1: D Series Cast Iron Gear Pump, Single Section

A
B1 B2
C
D
E
F
G
H
J

DE1

A Rotation - viewed from drive shaft

Code	Description
L	Left hand (counterclockwise)
R	Right hand (clockwise)

B1 Displacement

Code	Description
07	7.0 cm ³ /rev [0.43 in ³ /rev]
10	9.5 cm ³ /rev [0.58 in ³ /rev]
11	10.8 cm ³ /rev [0.66 in ³ /rev]
13	12.6 cm ³ /rev [0.77 in ³ /rev]
14	14.3 cm ³ /rev [0.87 in ³ /rev]
17	17.0 cm ³ /rev [1.04 in ³ /rev]
19	19.0 cm ³ /rev [1.16 in ³ /rev]
21	20.5 cm ³ /rev [1.25 in ³ /rev]

Code	Description
23	22.5 cm ³ /rev [1.37 in ³ /rev]
25	25.4 cm ³ /rev [1.55 in ³ /rev]
29	29.0 cm ³ /rev [1.77 in ³ /rev]
32	31.8 cm ³ /rev [1.94 in ³ /rev]
36	36.1 cm ³ /rev [2.20 in ³ /rev]
38	38.0 cm ³ /rev [2.32 in ³ /rev]
41	41.0 cm ³ /rev [2.50 in ³ /rev]
45	45.1 cm ³ /rev [2.75 in ³ /rev]

Single Pump Order Code (continued)



B2 Input Shaft

Code	Description
SE	SAE 9 tooth spline, 31.8 mm [1.25 in] length
SC	SAE 11 tooth spline, 38.1 mm [1.5 in] length
AC	SAE 11 tooth spline, 38.1 mm [1.5 in] length with 9T spline through drive
SF	11 tooth spline, 31.8 mm [1.25 in] length (special modified length)
SH	SAE 13 tooth spline, 41 mm [1.62 in] length
AH	SAE 13 tooth spline, 41 mm [1.62 in] length with 9T spline through drive
SV	15 tooth spline, 46 mm [1.81 in] length (use with mounting flange AR or BR)
PD	19 mm [3/4 in] diameter, 51 mm [2 in] length, with 3/16 key
PB	22 mm [7/8 in] diameter, 41 mm [1.62 in] length, with 1/4 key
PZ	25.4 mm [1 in] diameter, 46 mm [1.81 in] length with 1/4 key
TJ	1:8 taper, 22 mm [7/8 in] diameter, 49 mm [1.94 in] length, threaded
TH	1:8 taper, 22 mm [7/8 in] dia, 49 mm [1.94 in] length, threaded with locknut and washer
WT	Input shaft similar to TH option with 34 tooth helical gear for Perkins engine mount

C Mounting Flange

Code	Description
AA	SAE A 2-bolt
AC	SAE A 2-bolt, use with integral PFD/Steering Cover
AM	SAE A 2-bolt, with T seal
AP	SAE A 2-bolt, with T seal, use with integral PFD/Steering cover
AR	SAE A 2-bolt, use with 15 T spline input drive
AS	SAE A 2-bolt, use with integral PFD/Steering cover and 15 T input spline
AL	SAE A 2-bolt, two shaft seals with weep hole
AT	SAE A 2-bolt, two shaft seals with weep hole, use with integral PFD/Steering cover
BB	SAE B 2-bolt
BC	SAE B 2-bolt, use with integral PFD/Steering cover
BM	SAE B 2-bolt, with T seal
BP	SAE B 2-bolt, with T seal, use with integral PFD/Steering cover
BR	SAE B 2-bolt, use with 15 T spline input drive
BS	SAE B 2-bolt, use with integral PFD/Steering cover and 15 T input spline
BT	SAE B 2-bolt, two shaft seals with weep hole
BN	SAE B 2-bolt, two shaft seals with weep hole, use with integral PFD/Steering cover
PP	Perkins 6 bolt flange with (2) seals (use with WT input shaft and clockwise rotation)

D Series Cast Iron Gear Pumps Technical Information Model Code

Single Pump Order Code (continued)

	A	B1	B2	C	D	E	F	G	H	J
D	E	1								

D Rear Cover: Port Options, Integrated Valves and Auxiliary Flange

Code	Inlet	Outlet	Description
N101	1 1/16-12 side inlet	7/8-14 side outlet	SAE O-ring boss ports No integrated valves No auxiliary flange
N103	1 5/16-12 side inlet	7/8-14 side outlet	
N104	1 5/16-12 side inlet	1 1/16-12 side outlet	
N125	1 5/8-12 side inlet	1 1/16-12 side outlet	
N501	1 1/16-12 rear inlet	7/8-14 rear outlet	
N503	1 5/16-12 rear inlet	7/8-14 rear outlet	
N504	1 5/16-12 rear inlet	1 1/16-12 rear outlet	
N342	1 1/4 side split flange inlet	3/4 side split flange outlet (SAE code 61)	SAE split flange ports No integrated valves No auxiliary flange
N704	1 1/4 side tube inlet	7/8-14 side ORB outlet	Beaded tube inlet port, SAE O-ring boss outlet port No integrated valves No auxiliary flange
N708	1 1/4 side tube inlet	1 1/16-12 side ORB outlet	
N715	1 1/4 side tube inlet	1 1/16-12 side ORB outlet	
N720	1 1/4 side tube inlet	7/8-14 side ORB outlet	
B103*	1 5/16-12 side inlet	7/8-14 side outlet,	SAE-A 2-Bolt Auxiliary Flange SAE O-ring boss ports No integrated valves
B104*	1 5/16-12 side inlet	1 1/16-12 side outlet	
R104	1 5/16-12 side inlet	1 1/16-12 side outlet	Integrated Relief Valve Internally Drained
P09A**	1 5/16-12 side inlet, 3/4-16 side priority, 7/8-14 side secondary (SAE A flange)		Integrated Priority Flow Divider, parts-in body relief for settings up to: 138 bar and 22.7 l/min [2000 psi and 6 US gal/min]
P09B***	1 5/16-12 side inlet, 3/4-16 side priority, 7/8-14 side secondary (SAE B flange)		
F09A**	1 5/16-12 side inlet, 3/4-16 side priority, 7/8-14 side secondary (SAE A flange)		Integrated Priority Flow Divider, cartridge style relief for settings up to: 221bar and 34.3 l/min [3200 psi and 9 US gal/min]
F09B***	1 5/16-12 side inlet, 3/4-16 side priority, 7/8-14 side secondary (SAE B flange)		
F13A**	1 5/8-12 rear inlet, 3/4-16 rear priority, 7/8-14 rear secondary (SAE A flange)		
F13B***	1 5/8-12 rear inlet, 3/4-16 rear priority, 7/8-14 rear secondary (SAE B flange)		
F21A**	1 5/8-12 side inlet, 3/4-16 side priority, 7/8-14 side secondary (SAE A flange)		
F21B***	1 5/8-12 side inlet, 3/4-16 side priority, 7/8-14 side secondary (SAE B flange)		
F25A**	1 5/16-12 rear inlet, 3/4-16 rear priority, 7/8-14 rear secondary (SAE A flange)		
F25B***	1 5/16-12 rear inlet, 3/4-16 rear priority, 7/8-14 rear secondary (SAE B flange)		

* Integrated auxiliary flange requires use of input shaft option AH or AC

** Requires use of mounting flange option AC or AP

*** Requires use of mounting flange option BC or BP

D Series Cast Iron Gear Pumps

Technical Information

Model Code

Single Pump Order Code (continued)

A	B1	B2	C	D	E	F	G	H	J
D	E	1							

D Rear Cover: Port Options, Integrated Valves and Auxiliary Flange

Code	Inlet / Outlet	Description
S23A*	1 5/16-12 side inlet, 3/4-16 side priority, (SAE A flange)	Integrated Steering Cover, parts-in body relief for settings up to: 138 bar and 22.7 l/min [2000 psi and 6 US gal/min]
S23B**	1 5/16-12 side inlet, 3/4-16 side priority, (SAE B flange)	
D23A*	1 5/16-12 side inlet, 3/4-16 side priority, no secondary port (SAE A flange)	Integrated Steering Cover, Priority Relief Valve (Cartridge Style) for settings up to: 221 bar and 34.3 l/min [3200 psi and 9 US gal/min]
D23B**	1 5/16-12 side inlet, 3/4-16 side priority, no secondary port (SAE B flange)	
D24A*	1 5/16-12 rear inlet, 3/4-16 rear priority, no secondary port (SAE A flange)	
D24B**	1 5/16-12 rear inlet, 3/4-16 rear priority, no secondary port (SAE B flange)	
L01A	1 5/16-12 side inlet, 3/4-16 side priority, 7/8-14 side secondary, 7/16-20 side LS (SAE-A flange)	Integrated Load Sense Divider (Dynamic), Priority Relief Valve
L01B	1 5/16-12 side inlet, 3/4-16 side priority, 7/8-14 side secondary, 7/16-20 side LS (SAE-B flange)	
L08A	1 5/16-12 rear inlet, 3/4-16 rear priority, 7/8-14 rear secondary, 7/16-20 rear LS (SAE-A flange)	
L08B	1 5/16-12 rear inlet, 3/4-16 rear priority, 7/8-14 rear secondary, 7/16-20 rear LS (SAE-B flange)	

* Requires use of mounting flange option AC or AP

** Requires use of mounting flange option BC or BP

A variety of integrated load sense priority flow divider covers are available from TurollaOCG. Please contact your technical representative to determine which hardware best suits specific application needs.

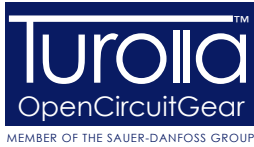

D Series Cast Iron Gear Pumps

Technical Information

Model Code

Single Pump Order Code (continued)



E Flow Control Valve Setting

Code	Description	
NNN	No flow control setting, standard for units without integrated flow control valves	
04N	3.8 l/min [1 US gal/min]	For integrated PFD Steering cover with parts in body relief valve (Cover options P09A, P09B, S23A, or S23B)
08N	7.6 l/min [2 US gal/min]	
11N	11.4 l/min [3 US gal/min]	
15N	15.1 l/min [4 US gal/min]	
19N	18.9 l/min [5 US gal/min]	
23N	22.7 l/min [6 US gal/min]	
04X	3.8 l/min [1 US gal/min]	For integrated PFD Steering cover with cartridge style relief valve (Cover options F09A, F09B, F13A, F13B, F21A, F21B, F25A or F25B)
08X	7.6 l/min [2 US gal/min]	
11X	11.4 l/min [3 US gal/min]	
15X	15.1 l/min [4 US gal/min]	
19X	18.9 l/min [5 US gal/min]	
23X	22.7 l/min [6 US gal/min]	
27X	26.5 l/min [7 US gal/min]	
30X	30.3 l/min [8 US gal/min]	
34X	34.3 l/min [9 US gal/min]	
38A	10 bar standby	For integrated load sense divider (use with L08A or L08B rear ports)
38L	10 bar standby	For integrated load sense divider (use with L01A or L01B side ports)

D Series Cast Iron Gear Pumps

Technical Information

Model Code

Single Pump Order Code (continued)

A			B1 B2			C		D			E			F			G			H			J		
D	E	1																							

F Pressure Control Valve Setting

Code	Description
000	No pressure control settings, standard for units without integrated pressure control valves
034	34 bar [500 psi]
041	41 bar [600 psi]
048	48 bar [700 psi]
055	55 bar [800 psi]
062	62 bar [900 psi]
069	69 bar [1000 psi]
076	76 bar [1100 psi]
083	83 bar [1200 psi]
090	90 bar [1300 psi]
097	97 bar [1400 psi]
103	103 bar [1500 psi]
110	110 bar [1600 psi]
117	117 bar [1700 psi]
124	124 bar [1800 psi]
131	131 bar [1900 psi]
138	138 bar [2000 psi]
145	145 bar [2100 psi]
152	152 bar [2200 psi]
159	159 bar [2300 psi]
165	165 bar [2400 psi]
172	172 bar [2500 psi]
179	179 bar [2600 psi]
186	186 bar [2700 psi]
193	193 bar [2800 psi]
200	200 bar [2900 psi]
207	207 bar [3000 psi]
214	214 bar [3100 psi]
221	221 bar [3200 psi]

For integrated PFD, cover with parts in body relief valve
(Cover options P09A, P09B, S23A, or S23B)
and
For integrated PFD cover with cartridge style relief valve
(Cover options F09A, F09B, F13A, F13B, F21A, F21B, F25A or F25B)

For integrated PFD cover with cartridge style relief valve
(Cover options F09A, F09B, F13A, F13B, F21A, F21B, F25A or F25B)

D Series Cast Iron Gear Pumps

Technical Information

Model Code

Single Pump Order Code (continued)



G Assembly Screws - depending upon rear cover
(Choose Table 1 or Table 2)

Table 1. Single pumps without auxiliary cover or integrated valves

Displacement (Module B)	Rear Cover - Controls & Ports (Module D)	
	N101, N103, N104, N501, N503, N504, N704, N708	N125
07	AF	AJ
10	AG	AJ
11	AG	AJ
13	AG	AJ
14	AG	AK
17	AH	AK
19	AH	AK
21	AH	AL
23	AJ	AL
25	AJ	AL
29	AK	AM
32	AK	AM
36	AL	AN
38	AL	AN
41	AM	AP
45	AM	AR

Table 2. Single pumps with auxiliary cover or integrated valves, dependent on rotation

Displacement (Module B)	Rear Cover - Controls & Ports (Module D)						
	Right Hand (CW) Rotation			Left Hand (CCW) Rotation			
	P09A, F09A F13A, F21A S23A	P09B, F09B F13B, F21B S23B	B104	P09A, F09A F13A, F21A	P09B, F09B F13B, F21B S23B	B104	S23A
07	CV	DG	AG	EM	DG	AG	CV
10	CV	DG	AH	EM	DG	AH	CV
11	CV	DG	AH	EM	DG	AH	CV
13	CX	DJ	AH	EP	DJ	AH	CX
14	CX	DJ	AH	EP	DJ	AH	CX
17	CY	DK	AJ	ER	DK	AJ	CY
19	CZ	DL	AJ	ES	DL	AJ	CZ
21	CZ	DL	AJ	ES	DL	AJ	CZ
23	CZ	DM	AJ	ES	DM	AJ	CZ
25	DA	DN	AK	ET	DN	AK	DA
29	DB	DP	AK	EY	DP	AK	DB
32	DC	DR	AL	EU	DR	AL	DC
36	DD	DS	AM	EV	DS	AM	DD
38	DE	DT	AM	EW	DT	AM	DE
41	DE	DT	AM	EW	DT	AM	DE
45	DF	DU	AN	EX	DU	AN	DF

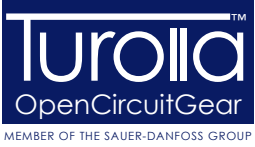

D Series Cast Iron Gear Pumps

Technical Information

Model Code

Single Pump Order Code (continued)

A				B1 B2		C		D			E		F		G		H		J		
D	E	1																			

H Nameplate

Code	Description
AN	Standard nameplate
BN	Standard label (use with rear cover code N501, N503, N504)

J Special Features

Code	Description
NNN	No special features, standard black paint

D Series Cast Iron Gear Pumps

Technical Information

Model Code

Two Section (Tandem) Pump Order Code

Example

The order code below provides an example of a two section (tandem) pump.

A
B1 B2
C
R
S
D
E
F
G
H
J

DE2R -
 23SH -
 BB -
 104 -
 13 -
 N113 -
 NNN -
 000 -
 AV -
 AC -
 NNN

Code	Position	Description
DE2R	A	D Series pump with two pumping sections, right hand rotation
23	B1	23 cm ³ displacement on first section
SH	B2	13 tooth spline input shaft
BB	C	SAE B two bolt mounting flange
104	R	1 5/16-12 side inlet, 1 1/16 side outlet on first section
13	S	13 cm ³ displacement on second section
N113	D	No inlet and 7/8-14 side outlet on second section
NNN	E	No flow control setting
000	F	No pressure control setting
AV	G	Assembly screws
AC	H	Standard Nameplate
NNN	J	No special features, black paint

DE2: D Series Cast Iron Gear Pump, Two Sections (Tandem)

A
B1 B2
C
R
S
D
E
F
G
H
J

DE2R -
 -
 -
 -
 -
 -
 -
 -
 -
 -

A Rotation - viewed from drive shaft

Code	Description
L	Left hand (counterclockwise)
R	Right hand (clockwise)

B1 Displacement - First Section

Code	Description
07	7.0 cm ³ /rev [0.43 in ³ /rev]
10	9.5 cm ³ /rev [0.58 in ³ /rev]
11	10.8 cm ³ /rev [0.66 in ³ /rev]
13	12.6 cm ³ /rev [0.77 in ³ /rev]
14	14.3 cm ³ /rev [0.87 in ³ /rev]
17	17.0 cm ³ /rev [1.04 in ³ /rev]
19	19.0 cm ³ /rev [1.16 in ³ /rev]
21	20.5 cm ³ /rev [1.25 in ³ /rev]

Code	Description
23	22.5 cm ³ /rev [1.37 in ³ /rev]
25	25.4 cm ³ /rev [1.55 in ³ /rev]
29	29.0 cm ³ /rev [1.77 in ³ /rev]
32	31.8 cm ³ /rev [1.94 in ³ /rev]
36	36.1 cm ³ /rev [2.20 in ³ /rev]
38	38.0 cm ³ /rev [2.32 in ³ /rev]
41	41.0 cm ³ /rev [2.50 in ³ /rev]
45	45.1 cm ³ /rev [2.75 in ³ /rev]

**Two Section (Tandem)
Pump Order Code
(continued)**



B2 Input Shaft

Code	Description
SE	SAE 9 tooth spline, 31.8 mm [1.25 in] length
SC	SAE 11 tooth spline, 38.1 mm [1.50 in] length
SF	11 tooth spline, 31.8 mm [1.25 in] length (special modified length)
SH	SAE 13 tooth spline, 41 mm [1.62 in] length
SV	15 tooth spline, 46 mm [1.81 in] length (requires mounting flange AR or BR)
PD	19 mm [3/4 in] diameter x 51 mm [2.0 in] length, with 3/16 inch key
PB	22 mm [7/8 in] diameter x 41 mm [1.62 in] length, with 1/4 inch key
PZ	25.4 mm [1 inch] diameter x 46 mm [1.81 in] length, with 1/4 inch key
TJ	1:8 taper, 22mm [7/8 in] diameter x 49mm [1.94 in] length, threaded
TH	1:8 taper, 22mm [7/8 in] diameter x 49mm [1.94in] length, threaded with nut/washer

C: Mounting Flange

Code	Description
AA	SAE A 2-bolt
AC	SAE A 2-bolt, use with integral PFD/Steering Cover
AM	SAE A 2-bolt, with T seal
AP	SAE A 2-bolt, with T seal, use with integral PFD/Steering cover
AR	SAE A 2-bolt, use with 15 T spline input drive
AS	SAE A 2-bolt, use with integral PFD/Steering cover and 15 T input spline
AL	SAE A 2-bolt, two shaft seals with weep hole
AT	SAE A 2-bolt, two shaft seals with weep hole, use with integral PFD/Steering cover
BB	SAE B 2-bolt
BC	SAE B 2-bolt, use with integral PFD/Steering cover
BM	SAE B 2-bolt, with T seal
BP	SAE B 2-bolt, with T seal, use with integral PFD/Steering cover
BR	SAE B 2-bolt, use with 15 T spline input drive
BS	SAE B 2-bolt, use with integral PFD/Steering cover and 15 T input spline
BT	SAE B 2-bolt, two shaft seals with weep hole
BN	SAE B 2-bolt, two shaft seals with weep hole, use with integral PFD/Steering cover
PP	Perkins 6 bolt flange with (2) seals (use with WT input shaft and clockwise rotation)

D Series Cast Iron Gear Pumps

Technical Information

Model Code

Two Section (Tandem) Pump Order Code (continued)

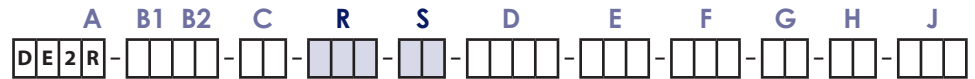

R Ports - First Section

Code	Description	
101	1 1/16-12 side inlet, 7/8-14 side outlet	SAE O-ring boss ports No integrated valves
103	1 5/16-12 side inlet, 7/8-14 side outlet	
104	1 5/16-12 side inlet, 1 1/16-12 side outlet	
113	No inlet, 7/8-14 side outlet	
125	1 5/8-12 side inlet, 1 1/16-12 side outlet	
126	No inlet, 1 1/16-12 side outlet	
704	1 1/4 side tube inlet, 7/8-14 side ORB outlet	Beaded tube inlet port SAE O-ring boss outlet port No integrated valves
708	1 1/4 side tube inlet, 1 1/16-12 side ORB outlet	
716	1 1/2 side tube inlet, 1 1/16-12 side ORB outlet	
717	1 1/2 side tube inlet, 7/8-14 side ORB outlet	

S Displacement - Second Section

Code	Description	Code	Description
07	7.0 cm ³ /rev [0.43 in ³ /rev]	23	22.5 cm ³ /rev [1.37 in ³ /rev]
10	9.5 cm ³ /rev [0.58 in ³ /rev]	25	25.4 cm ³ /rev [1.55 in ³ /rev]
11	10.8 cm ³ /rev [0.66 in ³ /rev]	29	29.0 cm ³ /rev [1.77 in ³ /rev]
13	12.6 cm ³ /rev [0.77 in ³ /rev]	32	31.8 cm ³ /rev [1.94 in ³ /rev]
14	14.3 cm ³ /rev [0.87 in ³ /rev]	36	36.1 cm ³ /rev [2.20 in ³ /rev]
17	17.0 cm ³ /rev [1.04 in ³ /rev]	38	38.0 cm ³ /rev [2.32 in ³ /rev]
19	19.0 cm ³ /rev [1.16 in ³ /rev]	41	41.0 cm ³ /rev [2.50 in ³ /rev]
21	20.5 cm ³ /rev [1.25 in ³ /rev]	45	45.1 cm ³ /rev [2.75 in ³ /rev]

D Series Cast Iron Gear Pumps

Technical Information

Model Code

Two Section (Tandem) Pump Order Code (continued)

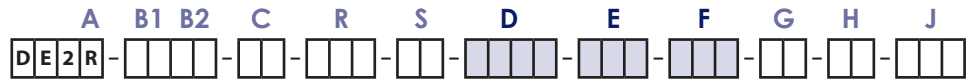

D Rear Cover: Port Options, Integrated Valves and Auxiliary Flange

Code	Inlet	Outlet	Description
N101	1 1/16-12 side inlet	7/8-14 side outlet	SAE O-ring boss ports No integrated valves No auxiliary flange
N103	1 5/16-12 side inlet	7/8-14 side outlet	
N104	1 5/16-12 side inlet	1 1/16-12 side outlet	
N113	No inlet	7/8-14 side outlet	
N125	1 5/8-12 side inlet	1 1/16-12 side outlet	
N501	1 1/16-12 rear inlet	7/8-14 rear outlet	
N503	1 5/16-12 rear inlet	7/8-14 rear outlet	
N504	1 5/16-12 rear inlet	1 1/16-12 rear outlet	
N342	1 1/4 side split flange inlet	3/4 side split flange outlet (SAE code 61)	SAE split flange ports No integrated valves No auxiliary flange
N704	1 1/4 side tube inlet	7/8-14 side ORB outlet	Beaded tube inlet port, SAE O-ring boss outlet port No integrated valves No auxiliary flange
N708	1 1/4 side tube inlet	1 1/16-12 side ORB outlet	
N715	1 1/4 side tube inlet	1 1/16-12 side ORB outlet	
N720	1 1/4 side tube inlet	7/8-14 side ORB outlet	
B103*	1 5/16-12 side inlet	7/8-14 side outlet,	SAE-A 2-Bolt Auxiliary Flange SAE O-ring boss ports No integrated valves
B104*	1 5/16-12 side inlet	1 1/16-12 side outlet	
R104	1 5/16-12 side inlet	1 1/16-12 side outlet	Integrated Relief Valve Internally Drained

A variety of integrated valve options including PFD, Steering Covers, and Load sense priority flow dividers covers are available with D Series multiple pumps. Please contact your technical representative to determine which hardware best suits specific application needs.

E Flow Control Valve

Code	Description
NNN	No flow control setting

F Pressure Control Valve

Code	Description
000	No pressure control setting

D Series Cast Iron Gear Pumps Technical Information Model Code

Two Section (Tandem) Pump Order Code (continued)



G Assembly screws

- Step 1 - Select the table corresponding to the port codes of the front and rear pump
- Step 2 - Select the row corresponding to the displacement of the front pump
- Step 3 - Select the column corresponding to the displacement of the rear pump
- Step 4 - Select the 2 letter code where the two displacements meet

Example from Table 1: AW = 21+19 tandem

The following tables are only applicable to port codes shown. For all other port code options (including PFD, LS and auxiliary cover), please consult factory.

Table number	Front pump port code Module R	Rear pump port code Module D
1	101, 103, 104, 113, 126, 704 or 708	N101, N103, N104, N113, N126, N501, N503, N504, N704, or N708
2	125, 716, 717	N101, N103, N104, N113, N126, N501, N503, N504, N704, or N708
3	101, 103, 104, 113, 126, 704 or 708	N125
4	125, 716, 717	N125

Displacement front pump (Module B)	Table 1 Front pump port code, Module: R = 101, 103, 104, 113, 126, 704, or 708 Rear pump port code, Module: D = N101, N103, N104, N113, N126, N501, N503, N504, N704, or N708 Displacement rear pump, Module: S														
	07	10	13	14	17	19	21	23	25	29	32	36	38	41	45
07	AS	AS	AS	AT	AT	AT	AU	AU	AU	AV	AV	AW	AW	AX	AY
10	AS	AS	AT	AT	AU	AU	AU	AU	AV	AV	AW	AX	AX	AX	AY
13	AS	AT	AT	AU	AU	AU	AV	AV	AV	AW	AW	AX	AX	AY	AY
14	AT	AT	AU	AU	AU	AV	AV	AV	AW	AW	AX	AX	AY	AY	AZ
17	AT	AU	AU	AU	AV	AV	AV	AW	AW	AX	AX	AY	AY	AY	AZ
19	AT	AU	AU	AV	AV	AV	AW	AW	AW	AX	AX	AY	AZ	AZ	AZ
21	AU	AU	AV	AV	AV	AW	AW	AW	AX	AX	AY	AY	AZ	AZ	BA
23	AU	AU	AV	AV	AW	AW	AW	AW	AX	AX	AY	AZ	AZ	AZ	BA
25	AU	AV	AV	AW	AW	AW	AX	AX	AX	AY	AZ	AZ	AZ	BA	BA
29	AV	AV	AW	AW	AX	AX	AX	AX	AY	AY	AZ	AZ	BA	BA	BB
32	AV	AW	AW	AX	AX	AX	AY	AY	AY	AZ	AZ	BA	BA	BB	BB
36	AW	AX	AX	AX	AY	AY	AY	AY	AZ	AZ	BA	BA	BB	BB	BC
38	AW	AX	AX	AY	AY	AY	AZ	AZ	AZ	BA	BA	BB	BB	BC	BC
41	AX	AX	AY	AY	AY	AZ	AZ	AZ	BA	BA	BB	BB	BC	BC	BD
45	AY	AY	AY	AZ	AZ	AZ	BA	BA	BA	BB	BB	BC	BC	BD	BE

D Series Cast Iron Gear Pumps

Technical Information

Model Code

Two Section (Tandem)
Pump Order Code
(continued)



G Assembly screws (continued)

Table 2	Front pump port code, Module: R = 125, 716, 717 Rear pump port code, Module: D = N101, N103, N104, N113, N126, N501, N503, N504, N704, or N708														
	Displacement rear pump, Module: S														
Displacement front pump (Module B)	07	10	13	14	17	19	21	23	25	29	32	36	38	41	45
07	AT	AT	AU	AU	AV	AV	AV	AV	AW	AW	AX	AY	AY	AY	AZ
10	AT	AU	AU	AV	AV	AV	AV	AW	AW	AX	AX	AY	AY	AZ	AZ
13	AU	AU	AV	AV	AV	AW	AW	AW	AX	AX	AY	AY	AZ	AZ	BA
14	AU	AV	AV	AV	AW	AW	AW	AX	AX	AY	AY	AZ	AZ	AZ	BA
17	AV	AV	AV	AW	AW	AW	AX	AX	AX	AY	AY	AZ	AZ	BA	BB
19	AV	AV	AW	AW	AW	AX	AX	AX	AY	AY	AZ	AZ	BA	BA	BB
21	AV	AV	AW	AW	AX	AX	AX	AY	AY	AZ	AZ	BA	BA	BA	BB
23	AV	AW	AW	AX	AX	AX	AY	AY	AY	AZ	AZ	BA	BA	BB	BB
25	AW	AW	AX	AX	AY	AY	AY	AY	AZ	AZ	BA	BA	BB	BB	BC
29	AW	AX	AX	AY	AY	AY	AY	AZ	AZ	BA	BA	BB	BB	BC	BC
32	AX	AX	AY	AY	AY	AZ	AZ	AZ	BA	BA	BB	BB	BC	BC	BD
36	AY	AY	AY	AZ	AZ	AZ	AZ	BA	BA	BB	BB	BC	BC	BD	BE
38	AY	AY	AZ	AZ	AZ	BA	BA	BA	BB	BB	BC	BC	BD	BD	BE
41	AY	AZ	AZ	AZ	BA	BA	BA	BB	BB	BC	BC	BD	BD	BE	BE
45	AZ	AZ	BA	BA	BB	BB	BB	BB	BC	BC	BD	BE	BE	BE	BF

Table 3	Front pump port code, Module: R = 101, 103, 104, 113, 126, 704, or 708 Rear pump port code, Module: D = N125														
	Displacement rear pump, Module: S														
Displacement front pump (Module B)	07	10	13	14	17	19	21	23	25	29	32	36	38	41	45
07	AU	AU	AV	AV	AW	AW	AW	AW	AX	AX	AY	AZ	AZ	AZ	BA
10	AU	AV	AV	AV	AW	AW	AW	AX	AX	AY	AY	AZ	AZ	AZ	BA
13	AV	AV	AW	AW	AW	AX	AX	AX	AY	AY	AZ	AZ	BA	BA	BB
14	AV	AV	AW	AW	AX	AX	AX	AY	AY	AZ	AZ	BA	BA	BA	BB
17	AW	AW	AW	AX	AX	AX	AY	AY	AY	AZ	AZ	BA	BA	BA	BC
19	AW	AW	AX	AX	AX	AY	AY	AY	AZ	AZ	BA	BA	BB	BB	BC
21	AW	AW	AX	AX	AY	AY	AY	AY	AZ	BA	BA	BB	BB	BB	BC
23	AW	AX	AX	AY	AY	AY	AY	AZ	AZ	BA	BA	BB	BB	BB	BC
25	AX	AX	AY	AY	AY	AZ	AZ	AZ	BA	BA	BB	BB	BC	BC	BD
29	AX	AY	AY	AZ	AZ	AZ	BA	BA	BA	BB	BB	BC	BC	BC	BD
32	AY	AY	AZ	AZ	AZ	BA	BA	BA	BB	BB	BC	BC	BD	BD	BE
36	AZ	AZ	AZ	BA	BA	BA	BB	BB	BB	BC	BC	BD	BD	BD	BF
38	AZ	AZ	BA	BA	BA	BA	BB	BB	BB	BC	BC	BD	BD	BE	BF
41	AZ	BA	BA	BA	BA	BB	BB	BB	BC	BC	BD	BD	BE	BE	BF
45	BA	BA	BB	BB	BC	BC	BC	BC	BD	BD	BE	BE	BF	BF	BG

D Series Cast Iron Gear Pumps

Technical Information

Model Code

Two Section (Tandem) Pump Order Code (continued)

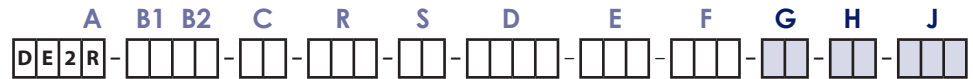

G Assembly screws (continued)

Table 4		Front pump port code, Module: R = 125, 716, 717 Rear pump port code, Module: D = N125													
Displacement front pump (Module B)	Displacement rear pump, Module: S														
	07	10	13	14	17	19	21	23	25	29	32	36	38	41	45
07	AV	AW	AW	AW	AX	AX	AX	AY	AY	AZ	AZ	BA	BA	BB	BB
10	AW	AW	AX	AX	AX	AY	AY	AY	AZ	AZ	BA	BA	BB	BB	BC
13	AW	AX	AX	AX	AY	AY	AY	AZ	AZ	BA	BA	BB	BB	BC	BC
14	AX	AX	AX	AY	AY	AY	AZ	AZ	AZ	BA	BA	BB	BB	BC	BC
17	AX	AX	AY	AY	AY	AZ	AZ	AZ	BA	BA	BB	BB	BC	BC	BD
19	AX	AY	AY	AY	AZ	AZ	AZ	BA	BA	BB	BB	BC	BC	BD	BD
21	AY	AY	AY	AZ	AZ	AZ	BA	BA	BA	BB	BB	BC	BC	BD	BD
23	AY	AY	AZ	AZ	AZ	BA	BA	BA	BB	BB	BC	BC	BD	BD	BE
25	AY	AZ	AZ	AZ	BA	BA	BA	BB	BB	BC	BC	BD	BD	BE	BE
29	AZ	AZ	BA	BA	BA	BA	BB	BB	BC	BC	BD	BD	BE	BE	BF
32	AZ	BA	BA	BA	BB	BB	BB	BC	BC	BD	BD	BE	BE	BF	BF
36	BA	BA	BB	BB	BB	BB	BC	BC	BD	BD	BE	BE	BF	BF	BG
38	BA	BB	BB	BB	BC	BC	BC	BD	BD	BE	BE	BF	BF	BG	BG
41	BB	BB	BC	BC	BC	BC	BC	BD	BE	BE	BF	BF	BG	BG	BH
45	BB	BC	BC	BC	BD	BD	BD	BE	BE	BF	BF	BG	BG	BH	BH

H Nameplate

Code	Description
AN	Standard nameplate
BN	Standard label (use with rear cover code N501, N503, N504)

J Special Features

Code	Description
NNN	No special features, standard black paint

D Series Cast Iron Gear Pumps

Technical Information

Model Code

Three Section (Triple) Pump Order Code

Example

The order code below provides an example of a three section (triple) pump with single inlet.

A
B1 B2
C
L
M
R
S
D
E
F
G
H
J

DE3R -
 25SH -
 BB -
 716 -
 25 -
 126 -
 25 -
 N126 -
 NNN -
 000 -
 BM -
 AN -
 NNN

Code	Position	
DE3R	A	D Series pump with three pumping sections, right hand rotation
25	B1	25 cm ³ displacement on first section
SH	B2	13 tooth spline input shaft
BB	C	SAE B two bolt mounting flange
716	L	1 1/2 inch beaded tube inlet, 1 1/16-12 side ORB outlet on first section
25	M	25 cm ³ displacement on second section
126	R	No inlet and 1 1/16-12 side outlet on second section
25	S	25 cm ³ displacement on third section
N126	D	No inlet and 1 1/16-12 side outlet on third section
NNN	E	No flow control setting
000	F	No pressure control setting
BM	G	Assembly screws
AN	H	Standard Nameplate
NNN	J	No special features, black paint

DE3: D Series Cast Iron Gear Pump, Three Sections (Triple)

A
B1 B2
C
L
M
R
S
D
E
F
G
H
J

DE3 -
 -
 -
 -
 -
 -
 -
 -
 -
 -
 -
 -

A Rotation - viewed from drive shaft

Code	Description
L	Left hand (counterclockwise)
R	Right hand (clockwise)

B1 Displacement - First Section

Code	Description
07	7.0 cm ³ /rev [0.43 in ³ /rev]
10	9.5 cm ³ /rev [0.58 in ³ /rev]
11	10.8 cm ³ /rev [0.66 in ³ /rev]
13	12.6 cm ³ /rev [0.77 in ³ /rev]
14	14.3 cm ³ /rev [0.87 in ³ /rev]
17	17.0 cm ³ /rev [1.04 in ³ /rev]
19	19.0 cm ³ /rev [1.16 in ³ /rev]
21	20.5 cm ³ /rev [1.25 in ³ /rev]

Code	Description
23	22.5 cm ³ /rev [1.37 in ³ /rev]
25	25.4 cm ³ /rev [1.55 in ³ /rev]
29	29.0 cm ³ /rev [1.77 in ³ /rev]
32	31.8 cm ³ /rev [1.94 in ³ /rev]
36	36.1 cm ³ /rev [2.20 in ³ /rev]
38	38.0 cm ³ /rev [2.32 in ³ /rev]
41	41.0 cm ³ /rev [2.50 in ³ /rev]
45	45.1 cm ³ /rev [2.75 in ³ /rev]

Three Section (Triple) Pump Order Code (continued)



B2 Input Shaft

Code	Description
SE	SAE 9 tooth spline, 31.8 mm [1.25 in] length
SC	SAE 11 tooth spline, 38.1 mm [1.50 in] length
SF	11 tooth spline, 31.8 mm [1.25 in] length (special modified length)
SH	SAE 13 tooth spline, 41 mm [1.62 in] length
SV	15 tooth spline, 46 mm [1.81 in] length (requires mounting flange AR or BR)
PD	19 mm [3/4 in] diameter x 51 mm [2.0 in] length, with 3/16 inch key
PB	22 mm [7/8 in] diameter x 41 mm [1.62 in] length, with 1/4 inch key
PZ	25.4 mm [1 inch] diameter x 46 mm [1.81 in] length, with 1/4 inch key
TJ	1:8 taper, 22mm [7/8 in] diameter x 49mm [1.94 in] length, threaded
TH	1:8 taper, 22mm [7/8 in] diameter x 49mm [1.94in] length, threaded with nut/washer

C Mounting Flange

Code	Description
AA	SAE A 2-bolt
AC	SAE A 2-bolt, use with integral PFD/Steering Cover
AM	SAE A 2-bolt, with T seal
AP	SAE A 2-bolt, with T seal, use with integral PFD/Steering cover
AR	SAE A 2-bolt, use with 15 T spline input drive
AS	SAE A 2-bolt, use with integral PFD/Steering cover and 15 T input spline
AL	SAE A 2-bolt, two shaft seals with weep hole
AT	SAE A 2-bolt, two shaft seals with weep hole, use with integral PFD/Steering cover
BB	SAE B 2-bolt
BC	SAE B 2-bolt, use with integral PFD/Steering cover
BM	SAE B 2-bolt, with T seal
BP	SAE B 2-bolt, with T seal, use with integral PFD/Steering cover
BR	SAE B 2-bolt, use with 15 T spline input drive
BS	SAE B 2-bolt, use with integral PFD/Steering cover and 15 T input spline
BT	SAE B 2-bolt, two shaft seals with weep hole
BN	SAE B 2-bolt, two shaft seals with weep hole, use with integral PFD/Steering cover
PP	Perkins 6 bolt flange with (2) seals (use with WT input shaft and clockwise rotation)

Three Section (Triple) Pump Order Code (continued)

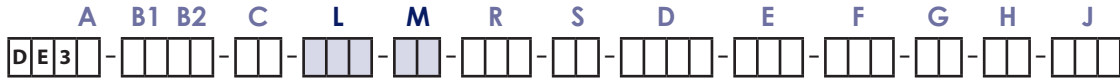

L Ports - First Section

Code	Description	
101	1 1/16-12 side inlet, 7/8-14 side outlet	SAE O-ring boss ports No integrated valves
103	1 5/16-12 side inlet, 7/8-14 side outlet	
104	1 5/16-12 side inlet, 1 1/16-12 side outlet	
113	No inlet, 7/8-14 side outlet	
125	1 5/8-12 side inlet, 1 1/16-12 side outlet	
126	No inlet, 1 1/16-12 side outlet	
704	1 1/4 side tube inlet, 7/8-14 side ORB outlet	Beaded tube inlet port SAE O-ring boss outlet port No integrated valves
708	1 1/4 side tube inlet, 1 1/16-12 side ORB outlet	
716	1 1/2 side tube inlet, 1 1/16-12 side ORB outlet	
717	1 1/2 side tube inlet, 7/8-14 side ORB outlet	

M Displacement - Second Section

Code	Description	Code	Description
07	7.0 cm ³ /rev [0.43 in ³ /rev]	23	22.5 cm ³ /rev [1.37 in ³ /rev]
10	9.5 cm ³ /rev [0.58 in ³ /rev]	25	25.4 cm ³ /rev [1.55 in ³ /rev]
11	10.8 cm ³ /rev [0.66 in ³ /rev]	29	29.0 cm ³ /rev [1.77 in ³ /rev]
13	12.6 cm ³ /rev [0.77 in ³ /rev]	32	31.8 cm ³ /rev [1.94 in ³ /rev]
14	14.3 cm ³ /rev [0.87 in ³ /rev]	36	36.1 cm ³ /rev [2.20 in ³ /rev]
17	17.0 cm ³ /rev [1.04 in ³ /rev]	38	38.0 cm ³ /rev [2.32 in ³ /rev]
19	19.0 cm ³ /rev [1.16 in ³ /rev]	41	41.0 cm ³ /rev [2.50 in ³ /rev]
21	20.5 cm ³ /rev [1.25 in ³ /rev]	45	45.1 cm ³ /rev [2.75 in ³ /rev]

Three Section (Triple) Pump Order Code (continued)

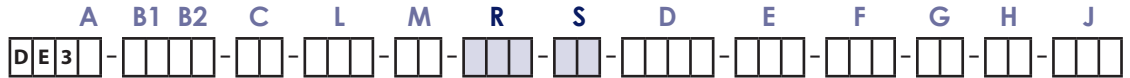

R Ports - Second Section

Code	Description	
101	1 1/16-12 side inlet, 7/8-14 side outlet	SAE O-ring boss ports No integrated valves
103	1 5/16-12 side inlet, 7/8-14 side outlet	
104	1 5/16-12 side inlet, 1 1/16-12 side outlet	
113	No inlet, 7/8-14 side outlet	
125	1 5/8-12 side inlet, 1 1/16-12 side outlet	
126	No inlet, 1 1/16-12 side outlet	
704	1 1/4 side tube inlet, 7/8-14 side ORB outlet	Beaded tube inlet port SAE O-ring boss outlet port No integrated valves
708	1 1/4 side tube inlet, 1 1/16-12 side ORB outlet	
716	1 1/2 side tube inlet, 1 1/16-12 side ORB outlet	
717	1 1/2 side tube inlet, 7/8-14 side ORB outlet	

S Displacement - Third Section

Code	Description	Code	Description
07	7.0 cm ³ /rev [0.43 in ³ /rev]	23	22.5 cm ³ /rev [1.37 in ³ /rev]
10	9.5 cm ³ /rev [0.58 in ³ /rev]	25	25.4 cm ³ /rev [1.55 in ³ /rev]
11	10.8 cm ³ /rev [0.66 in ³ /rev]	29	29.0 cm ³ /rev [1.77 in ³ /rev]
13	12.6 cm ³ /rev [0.77 in ³ /rev]	32	31.8 cm ³ /rev [1.94 in ³ /rev]
14	14.3 cm ³ /rev [0.87 in ³ /rev]	36	36.1 cm ³ /rev [2.20 in ³ /rev]
17	17.0 cm ³ /rev [1.04 in ³ /rev]	38	38.0 cm ³ /rev [2.32 in ³ /rev]
19	19.0 cm ³ /rev [1.16 in ³ /rev]	41	41.0 cm ³ /rev [2.50 in ³ /rev]
21	20.5 cm ³ /rev [1.25 in ³ /rev]	45	45.1 cm ³ /rev [2.75 in ³ /rev]

D Series Cast Iron Gear Pumps Technical Information Model Code

Three Section (Triple) Pump Order Code (continued)

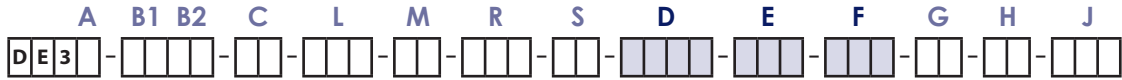

D Rear Cover: Third Section Ports, Integrated Valves and Auxiliary Flange

Code	Inlet	Outlet	Description
N101	1 1/16-12 side inlet	7/8-14 side outlet	SAE O-ring boss ports No integrated valves No auxiliary flange
N103	1 5/16-12 side inlet	7/8-14 side outlet	
N104	1 5/16-12 side inlet	1 1/16-12 side outlet	
N113	No inlet	7/8-14 side outlet	
N125	1 5/8-12 side inlet	1 1/16-12 side outlet	
N501	1 1/16-12 rear inlet	7/8-14 rear outlet	
N503	1 5/16-12 rear inlet	7/8-14 rear outlet	
N504	1 5/16-12 rear inlet	1 1/16-12 rear outlet	
N342	1 1/4 side split flange inlet	3/4 side split flange outlet (SAE code 61)	SAE split flange ports No integrated valves No auxiliary flange
N704	1 1/4 side tube inlet	7/8-14 side ORB outlet	Beaded tube inlet port, SAE O-ring boss outlet port No integrated valves No auxiliary flange
N708	1 1/4 side tube inlet	1 1/16-12 side ORB outlet	
N715	1 1/4 side tube inlet	1 1/16-12 side ORB outlet	
N720	1 1/4 side tube inlet	7/8-14 side ORB outlet	

A variety of integrated valve options including PFD, Steering Covers, and Load sense priority flow dividers covers are available with D Series multiple pumps. Please contact your technical representative to determine which hardware best suits specific application needs.

E Flow Control Valve

Code	Description
NNN	No flow control setting

F Pressure Control Valve

Code	Description
000	No pressure control setting

Three Section (Triple) Pump Order Code (continued)



G *Assembly Screws*

Code	Description
**	Contact your TuroliaOCG representative for assembly screw code

H *Nameplate*

Code	Description
AN	Standard nameplate
BN	Standard label (use with rear cover code N501, N503, N504)

J *Special Features*

Code	Description
NNN	No special features, standard black paint

D Series Cast Iron Gear Pumps

Technical Information

Model Code

Four Section (Quad) Pump Order Code

Example

The order code below provides an example of a four section (quad) pump with single inlet.

A **B1** **B2** **C** **L** **M** **N** **P** **R** **S** **D** **E** **F** **G** **H** **J**
DE4R - **25SH** - **BB** - **104** - **23** - **104** - **10** - **126** - **10** - **N126** - **NNN** - **000** - **BT** - **AN** - **NNN**

Code	Position	Description
DE4L	A	D Series pump with four pumping sections, left hand rotation
25	B1	25 cm ³ displacement on first section
SH	B2	13 tooth spline input shaft
BB	C	SAE B two bolt mounting flange
104	L	1 5/16-12 side inlet, 1 1/16-12 side outlet on first section
23	M	23 cm ³ displacement on second section
104	N	1 5/16-12 side inlet, 1 1/16-12 side outlet on second section
10	P	10 cm ³ displacement on third section
126	R	No inlet and 1 1/16-12 side outlet on third section
10	S	10 cm ³ displacement on fourth section
N126	D	No inlet and 1 1/16-12 side outlet on fourth section
NNN	E	No flow control setting
000	F	No pressure control setting
BT	G	Assembly screws
AN	H	Standard Nameplate
NNN	J	No special features, black paint

DE4: D Series Cast Iron Gear Pump, Four Sections (Quad)

A **B1** **B2** **C** **L** **M** **N** **P** **R** **S** **D** **E** **F** **G** **H** **J**
DE4 - [] - [] - [] - [] - [] - [] - [] - [] - [] - [] - [] - [] - [] - [] - []

A Rotation - viewed from drive shaft

Code	Description
L	Left hand (counterclockwise)
R	Right hand (clockwise)

B1 Displacement - First Section

Code	Description
07	7.0 cm ³ /rev [0.43 in ³ /rev]
10	9.5 cm ³ /rev [0.58 in ³ /rev]
11	10.8 cm ³ /rev [0.66 in ³ /rev]
13	12.6 cm ³ /rev [0.77 in ³ /rev]
14	14.3 cm ³ /rev [0.87 in ³ /rev]
17	17.0 cm ³ /rev [1.04 in ³ /rev]
19	19.0 cm ³ /rev [1.16 in ³ /rev]
21	20.5 cm ³ /rev [1.25 in ³ /rev]

Code	Description
23	22.5 cm ³ /rev [1.37 in ³ /rev]
25	25.4 cm ³ /rev [1.55 in ³ /rev]
29	29.0 cm ³ /rev [1.77 in ³ /rev]
32	31.8 cm ³ /rev [1.94 in ³ /rev]
36	36.1 cm ³ /rev [2.20 in ³ /rev]
38	38.0 cm ³ /rev [2.32 in ³ /rev]
41	41.0 cm ³ /rev [2.50 in ³ /rev]
45	45.1 cm ³ /rev [2.75 in ³ /rev]

Four Section (Quad) Pump Order Code (continued)



B2 Input Shaft

Code	Description
SE	SAE 9 tooth spline, 31.8 mm [1.25 in] length
SC	SAE 11 tooth spline, 38.1 mm [1.50 in] length
SF	11 tooth spline, 31.8 mm [1.25 in] length (special modified length)
SH	SAE 13 tooth spline, 41 mm [1.62 in] length
SV	15 tooth spline, 46 mm [1.81 in] length (requires mounting flange AR or BR)
PD	19 mm [3/4 in] diameter x 51 mm [2.0 in] length, with 3/16 inch key
PB	22 mm [7/8 in] diameter x 41 mm [1.62 in] length, with 1/4 inch key
PZ	25.4 mm [1 inch] diameter x 46 mm [1.81 in] length, with 1/4 inch key
TJ	1:8 taper, 22mm [7/8 in] diameter x 49mm [1.94 in] length, threaded
TH	1:8 taper, 22mm [7/8 in] diameter x 49mm [1.94in] length, threaded with nut/washer

C Mounting Flange

Code	Description
AA	SAE A 2-bolt
AC	SAE A 2-bolt, use with integral PFD/Steering Cover
AM	SAE A 2-bolt, with T seal
AP	SAE A 2-bolt, with T seal, use with integral PFD/Steering cover
AR	SAE A 2-bolt, use with 15 T spline input drive
AS	SAE A 2-bolt, use with integral PFD/Steering cover and 15 T input spline
AL	SAE A 2-bolt, two shaft seals with weep hole
AT	SAE A 2-bolt, two shaft seals with weep hole, use with integral PFD/Steering cover
BB	SAE B 2-bolt
BC	SAE B 2-bolt, use with integral PFD/Steering cover
BM	SAE B 2-bolt, with T seal
BP	SAE B 2-bolt, with T seal, use with integral PFD/Steering cover
BR	SAE B 2-bolt, use with 15 T spline input drive
BS	SAE B 2-bolt, use with integral PFD/Steering cover and 15 T input spline
BT	SAE B 2-bolt, two shaft seals with weep hole
BN	SAE B 2-bolt, two shaft seals with weep hole, use with integral PFD/Steering cover
PP	Perkins 6 bolt flange with (2) seals (use with WT input shaft and clockwise rotation)

Four Section (Quad) Pump Order Code (continued)

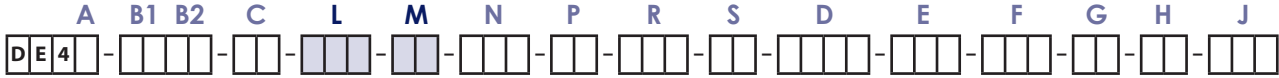

L Ports - First Section

Code	Description	
101	1 1/16-12 side inlet, 7/8-14 side outlet	SAE O-ring boss ports No integrated valves
103	1 5/16-12 side inlet, 7/8-14 side outlet	
104	1 5/16-12 side inlet, 1 1/16-12 side outlet	
113	No inlet, 7/8-14 side outlet	
125	1 5/8-12 side inlet, 1 1/16-12 side outlet	
126	No inlet, 1 1/16-12 side outlet	
704	1 1/4 side tube inlet, 7/8-14 side ORB outlet	Beaded tube inlet port SAE O-ring boss outlet port No integrated valves
708	1 1/4 side tube inlet, 1 1/16-12 side ORB outlet	
716	1 1/2 side tube inlet, 1 1/16-12 side ORB outlet	
717	1 1/2 side tube inlet, 7/8-14 side ORB outlet	

M Displacement - Second Section

Code	Description	Code	Description
07	7.0 cm ³ /rev [0.43 in ³ /rev]	23	22.5 cm ³ /rev [1.37 in ³ /rev]
10	9.5 cm ³ /rev [0.58 in ³ /rev]	25	25.4 cm ³ /rev [1.55 in ³ /rev]
11	10.8 cm ³ /rev [0.66 in ³ /rev]	29	29.0 cm ³ /rev [1.77 in ³ /rev]
13	12.6 cm ³ /rev [0.77 in ³ /rev]	32	31.8 cm ³ /rev [1.94 in ³ /rev]
14	14.3 cm ³ /rev [0.87 in ³ /rev]	36	36.1 cm ³ /rev [2.20 in ³ /rev]
17	17.0 cm ³ /rev [1.04 in ³ /rev]	38	38.0 cm ³ /rev [2.32 in ³ /rev]
19	19.0 cm ³ /rev [1.16 in ³ /rev]	41	41.0 cm ³ /rev [2.50 in ³ /rev]
21	20.5 cm ³ /rev [1.25 in ³ /rev]	45	45.1 cm ³ /rev [2.75 in ³ /rev]

Four Section (Quad) Pump Order Code (continued)



N Ports - Second Section

Code	Description	
101	1 1/16-12 side inlet, 7/8-14 side outlet	SAE O-ring boss ports No integrated valves
103	1 5/16-12 side inlet, 7/8-14 side outlet	
104	1 5/16-12 side inlet, 1 1/16-12 side outlet	
113	No inlet, 7/8-14 side outlet	
125	1 5/8-12 side inlet, 1 1/16-12 side outlet	
126	No inlet, 1 1/16-12 side outlet	
704	1 1/4 side tube inlet, 7/8-14 side ORB outlet	Beaded tube inlet port SAE O-ring boss outlet port No integrated valves
708	1 1/4 side tube inlet, 1 1/16-12 side ORB outlet	
716	1 1/2 side tube inlet, 1 1/16-12 side ORB outlet	
717	1 1/2 side tube inlet, 7/8-14 side ORB outlet	

P Displacement - Third Section

Code	Description	Code	Description
07	7.0 cm ³ /rev [0.43 in ³ /rev]	23	22.5 cm ³ /rev [1.37 in ³ /rev]
10	9.5 cm ³ /rev [0.58 in ³ /rev]	25	25.4 cm ³ /rev [1.55 in ³ /rev]
11	10.8 cm ³ /rev [0.66 in ³ /rev]	29	29.0 cm ³ /rev [1.77 in ³ /rev]
13	12.6 cm ³ /rev [0.77 in ³ /rev]	32	31.8 cm ³ /rev [1.94 in ³ /rev]
14	14.3 cm ³ /rev [0.87 in ³ /rev]	36	36.1 cm ³ /rev [2.20 in ³ /rev]
17	17.0 cm ³ /rev [1.04 in ³ /rev]	38	38.0 cm ³ /rev [2.32 in ³ /rev]
19	19.0 cm ³ /rev [1.16 in ³ /rev]	41	41.0 cm ³ /rev [2.50 in ³ /rev]
21	20.5 cm ³ /rev [1.25 in ³ /rev]	45	45.1 cm ³ /rev [2.75 in ³ /rev]

Four Section (Quad) Pump Order Code (continued)

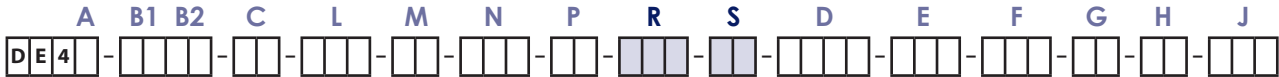

R Ports - Third Section

Code	Description	
101	1 1/16-12 side inlet, 7/8-14 side outlet	SAE O-ring boss ports No integrated valves
103	1 5/16-12 side inlet, 7/8-14 side outlet	
104	1 5/16-12 side inlet, 1 1/16-12 side outlet	
113	No inlet, 7/8-14 side outlet	
125	1 5/8-12 side inlet, 1 1/16-12 side outlet	
126	No inlet, 1 1/16-12 side outlet	
704	1 1/4 side tube inlet, 7/8-14 side ORB outlet	Beaded tube inlet port SAE O-ring boss outlet port No integrated valves
708	1 1/4 side tube inlet, 1 1/16-12 side ORB outlet	
716	1 1/2 side tube inlet, 1 1/16-12 side ORB outlet	
717	1 1/2 side tube inlet, 7/8-14 side ORB outlet	

S Displacement - Fourth Section

Code	Description	Code	Description
07	7.0 cm ³ /rev [0.43 in ³ /rev]	23	22.5 cm ³ /rev [1.37 in ³ /rev]
10	9.5 cm ³ /rev [0.58 in ³ /rev]	25	25.4 cm ³ /rev [1.55 in ³ /rev]
11	10.8 cm ³ /rev [0.66 in ³ /rev]	29	29.0 cm ³ /rev [1.77 in ³ /rev]
13	12.6 cm ³ /rev [0.77 in ³ /rev]	32	31.8 cm ³ /rev [1.94 in ³ /rev]
14	14.3 cm ³ /rev [0.87 in ³ /rev]	36	36.1 cm ³ /rev [2.20 in ³ /rev]
17	17.0 cm ³ /rev [1.04 in ³ /rev]	38	38.0 cm ³ /rev [2.32 in ³ /rev]
19	19.0 cm ³ /rev [1.16 in ³ /rev]	41	41.0 cm ³ /rev [2.50 in ³ /rev]
21	20.5 cm ³ /rev [1.25 in ³ /rev]	45	45.1 cm ³ /rev [2.75 in ³ /rev]

Four Section (Quad) Pump Order Code (continued)



D Rear Cover: Fourth Section Ports, Integrated Valves and Auxiliary Flange

Code	Inlet	Outlet	Description
N101	1 1/16-12 side inlet	7/8-14 side outlet	SAE O-ring boss ports No integrated valves No auxiliary flange
N103	1 5/16-12 side inlet	7/8-14 side outlet	
N104	1 5/16-12 side inlet	1 1/16-12 side outlet	
N113	No inlet	7/8-14 side outlet	
N125	1 5/8-12 side inlet	1 1/16-12 side outlet	
N126	No inlet	1 1/16-12 side outlet	
N501	1 1/16-12 rear inlet	7/8-14 rear outlet	
N503	1 5/16-12 rear inlet	7/8-14 rear outlet	
N504	1 5/16-12 rear inlet	1 1/16-12 rear outlet	
N342	1 1/4 side split flange inlet	3/4 side split flange outlet (SAE code 61)	SAE split flange ports No integrated valves No auxiliary flange
N704	1 1/4 side tube inlet	7/8-14 side ORB outlet	Beaded tube inlet port, SAE O-ring boss outlet port No integrated valves No auxiliary flange
N708	1 1/4 side tube inlet	1 1/16-12 side ORB outlet	
N715	1 1/4 side tube inlet	1 1/16-12 side ORB outlet	
N720	1 1/4 side tube inlet	7/8-14 side ORB outlet	

A variety of integrated valve options including PFD, Steering Covers, and Load sense priority flow dividers covers are available with D Series multiple pumps. Please contact your technical representative to determine which hardware best suits specific application needs.

E Flow Control Valve

Code	Description
NNN	No flow control setting

F Pressure Control Valve

Code	Description
000	No pressure control setting

Four Section (Quad) Pump Order Code (continued)



G *Assembly Screws*

Code	Description
**	Contact your TurollaOCG representative for assembly screw code

H *Nameplate*

Code	Description
AN	Standard nameplate
BN	Standard label (use with rear cover code N501, N503, N504)

J *Special Features*

Code	Description
NNN	No special features, standard black paint

Shaft Options



<p>Code SE SAE 9-tooth 16/32-pitch flat root side fit 31.8 mm [1.25 in] length</p> <p>Allowable shaft torque: 118.6 N•m [1050 lbf•in]</p>	<p>Code SC and AC SAE 11-tooth 16/32-pitch flat root side fit 38.1 mm [1.50 in] length</p> <p>AC option has 9T auxiliary drive output spline</p> <p>Allowable shaft torque: 176.3 N•m [1560 lbf•in]</p>	<p>Code SF SAE 11-tooth 16/32-pitch flat root side fit (modified length) 31.8 mm [1.25 in] length</p> <p>Allowable shaft torque: 176.3 N•m [1560 lbf•in]</p>
<p>Code SH and AH SAE 13-tooth 16/32-pitch flat root side fit 41.2 mm [1.62 in] length</p> <p>AH option has 9T auxiliary drive output spline</p> <p>Allowable shaft torque: 248.6 N•m [2200 lbf•in]</p>	<p>Code SV SAE 15-tooth 16/32-pitch flat root side fit 48.0 mm [1.81 in] length</p> <p>Allowable shaft torque: 452 N•m [4000 lbf•in]</p>	<p>Code PB - 22.2mm SAE 7/8 in straight keyed, 1/4 in key 41.2 mm [1.62 in] length</p> <p>Allowable shaft torque: 248.6 N•m [2200 lbf•in]</p>
<p>Code PD 19mm [3/4 inch] Dia. x 51mm [2.0 inch] 3/16 inch key</p> <p>Allowable shaft torque: 158.2 N•m [1400 lbf•in]</p>	<p>Code PZ 25.4mm [1 inch] Dia. x 46mm [1.62 inch] 1/4 inch key</p> <p>Allowable shaft torque: 452 N•m [4000 lbf•in]</p>	<p>Dimensions mm [in]</p>

Shaft Options (continued)

Dimensions mm [in]

Code TH

1:8 taper, 22mm [7/8 inch] diameter x 49.3 mm [1.94 in] length, threaded, with nut and washer

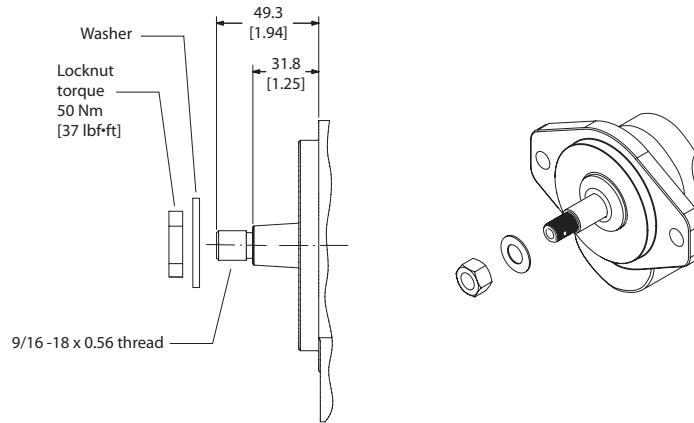

Allowable shaft torque:
225.9 N•m [2000 lbf•in]

Code TJ

1:8 taper, 22mm [7/8 inch] diameter x 49.3 mm [1.94 in] length, threaded, without nut and washer

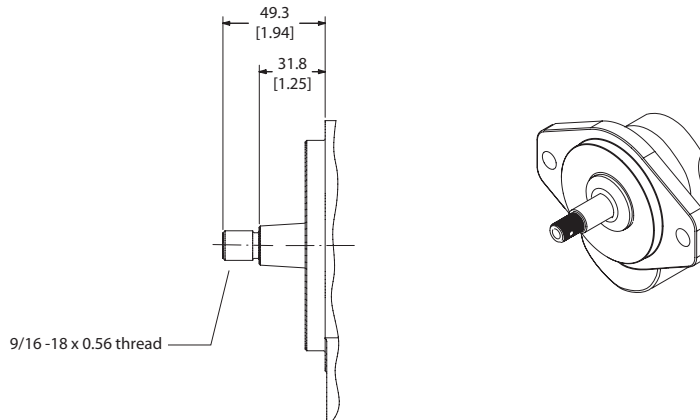

Allowable shaft torque:
225.9 N•m [2000 lbf•in]

Code WT

1:8 taper, 22mm [7/8 in] diameter x 49mm [1.94 in] length, threaded, with locknut, washer and 34 tooth helical gear for Perkins engine mount

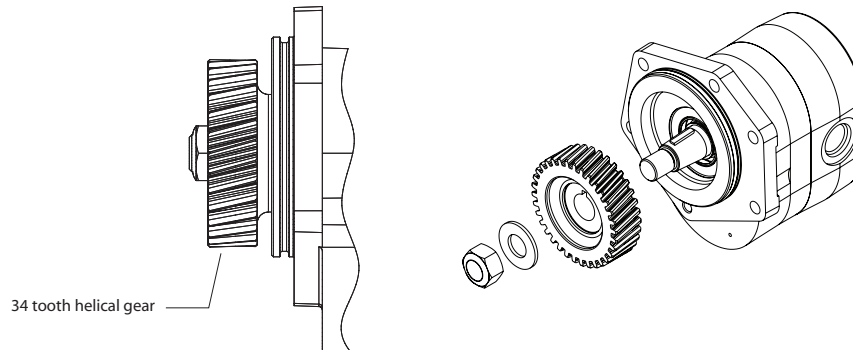

Code WT - Only available in 17cc, 19cc, 25cc, 32cc with clockwise (RH) rotation.
Use PP mounting flange option.

P108 172E

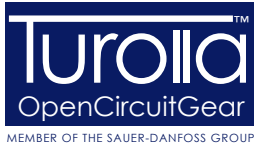

D Series Cast Iron Gear Pumps Technical Information Options

Shaft Options (continued)

Multiple pump connecting shaft

Allowable shaft torque between sections is 144 N·m [1273 lbf·in].

Limit operating pressures when applying multiple section pumps. This ensures the maximum simultaneous input torque through the drive shaft and connecting shafts. Do not exceed the *Allowable Shaft Torque Limits*.

D Series Cast Iron Gear Pumps

Technical Information

Options

Mounting Flanges

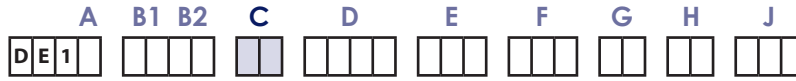

C Mounting Flange

Code	Description
AA	SAE A 2-bolt
AC	SAE A 2-bolt, use with integral PFD/Steering Cover
AM	SAE A 2-bolt, with T seal
AP	SAE A 2-bolt, with T seal, use with integral PFD/Steering cover
AR	SAE A 2-bolt, use with 15 T spline input drive
AS	SAE A 2-bolt, use with integral PFD/Steering cover and 15 T input spline
AL	SAE A 2-bolt, two shaft seals with weep hole
AT	SAE A 2-bolt, two shaft seals with weep hole, use with integral PFD/Steering cover

SAE A 2-bolt

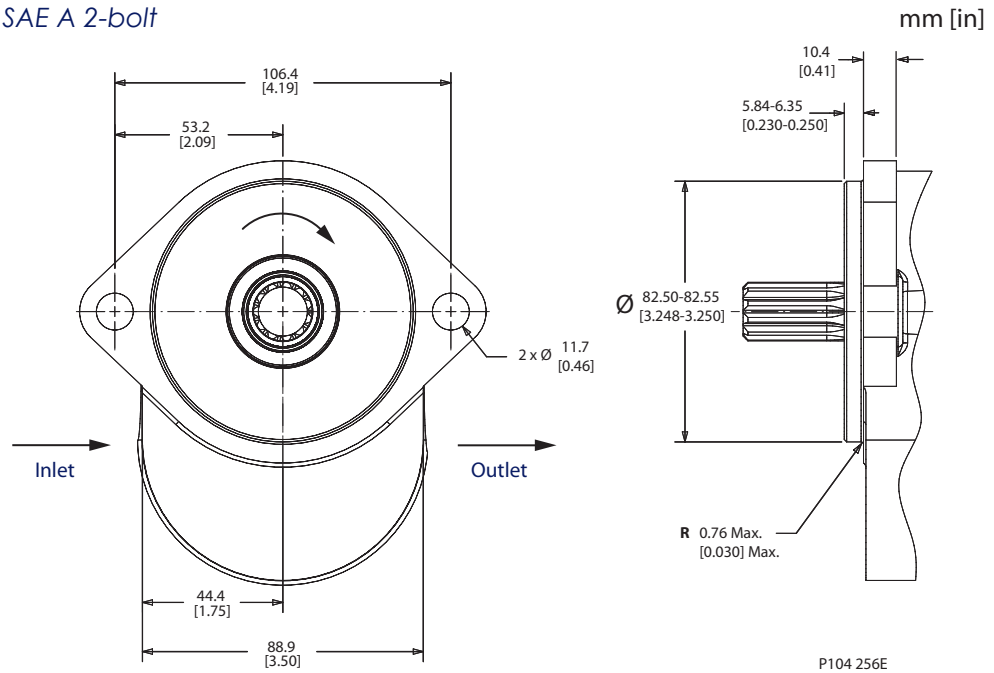

The optional **T-Seal** is a single piece shaft seal with back-to-back sealing lips. It is most commonly used to prevent mixing of internal/external fluids.

D Series Cast Iron Gear Pumps

Technical Information

Options

Mounting Flanges (continued)



C Mounting Flange

Code	Description
BB	SAE B 2-bolt
BC	SAE B 2-bolt, use with integral PFD/Steering cover
BM	SAE B 2-bolt, with T seal
BP	SAE B 2-bolt, with T seal, use with integral PFD/Steering cover
BR	SAE B 2-bolt, use with 15 T spline input drive
BS	SAE B 2-bolt, use with integral PFD/Steering cover and 15 T input spline
BT	SAE B 2-bolt, two shaft seals with weep hole
BN	SAE B 2-bolt, two shaft seals with weep hole, use with integral PFD/Steering cover

SAE B 2-bolt

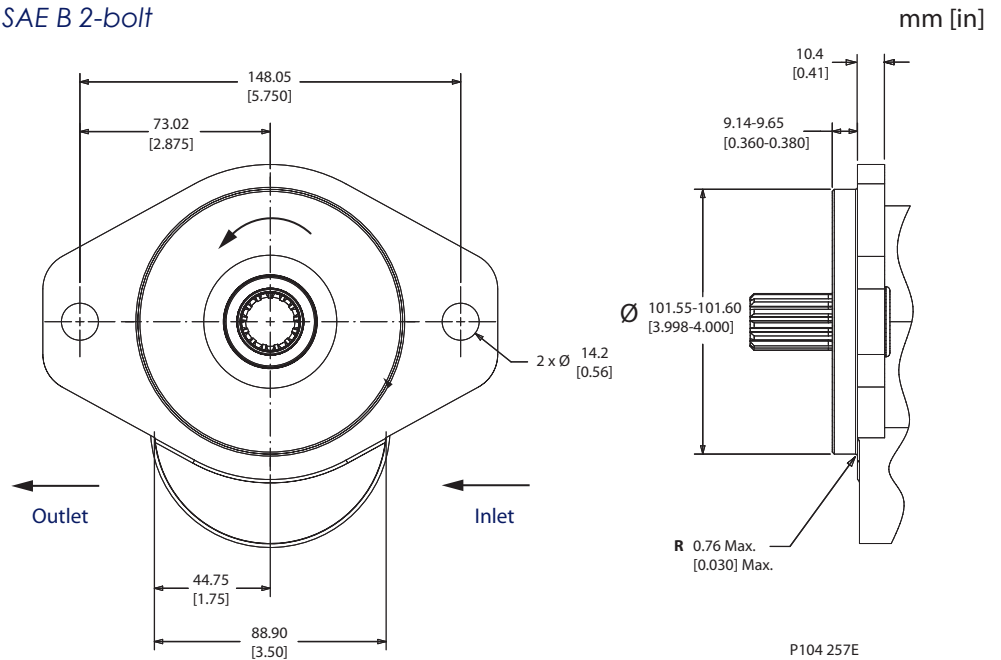

The optional **T-Seal** is a single piece shaft seal with back-to-back sealing lips. It is most commonly used to prevent mixing of internal/external fluids.

Mounting Flanges
(continued)



C Mounting Flange

Code	Description
PP	Perkins 6 bolt flange with (2) seals (use with WT input shaft and clockwise rotation)

Perkins® 1000 Series Engine Mount, shown with drive gear option WT and clockwise rotation

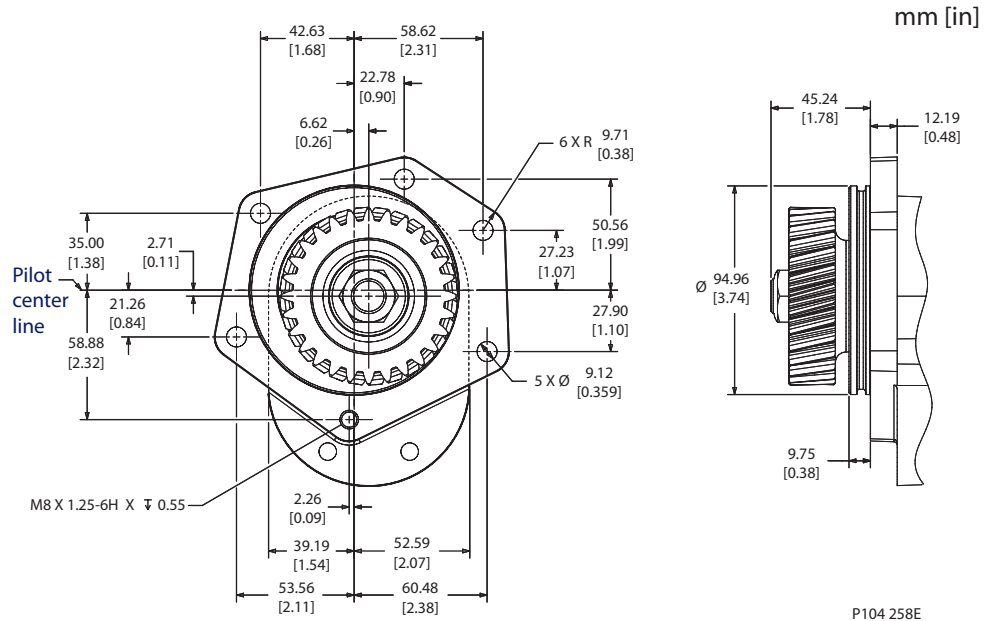

D Series Cast Iron Gear Pumps

Technical Information

Options

Multiple Pump Port Options

The D Series pump is uniquely designed to accommodate multiple pumps with a variety of porting configurations including units with a reduced number of inlets. Reducing the number of inlets can eliminate unnecessary hoses and fittings, thereby providing an overall system savings. A typical D series multiple pump does not have isolated sections. Applications requiring sealing between sections should use the SAE auxiliary flange to ensure separation of fluids between sections.

The reference drawings and model code options (R, L, and N) below, describe the first and intermediate port sections of multiple pump configurations. Refer to module D for port options on the final section of a multiple pump.

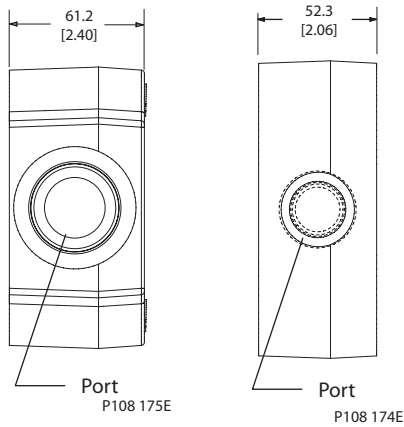
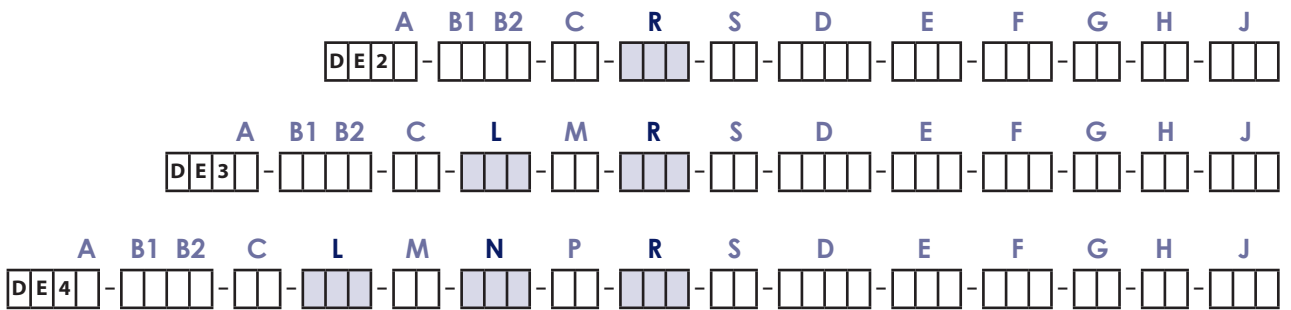

Port code options for modules R, L and N in multiple pump

Code	Inlet port	Outlet port	Maximum recommended inlet flow l/min [US gal/min]
101	1 1/16 - 12, SAE side	7/8 - 14, SAE side	49 [13]
103	1 5/16 - 12, SAE side	7/8 - 14, SAE side	91 [24]
104	1 5/16 - 12, SAE side	1 1/16 - 12, SAE side	91 [24]
113	No inlet	7/8 - 14 SAE, side	N/A
126	No inlet	1 1/16 - 12, side	N/A
704	1 1/4 side tube inlet	7/8 - 14, SAE side ORB	151 [40]
708	1 1/4 side tube inlet	1 1/16 - 12, SAE side ORB	151 [40]

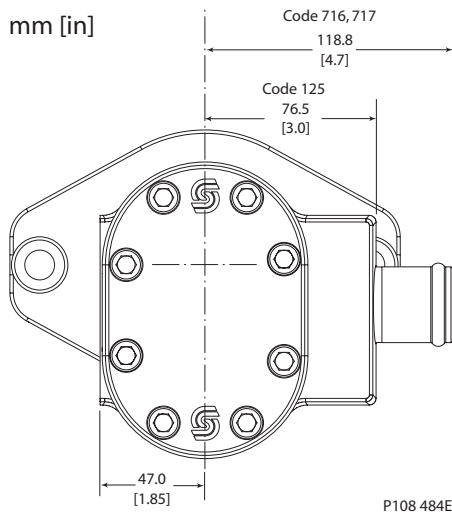

Codes 125, 716 and 717 are commonly used for large displacements and multiple pumps with reduced number of inlets

Code	Inlet port	Outlet port	Maximum recommended inlet flow l/min [US gal/min]
125	1 5/8 - 12, SAE side	1 1/16 - 12, side	151 [40]
716	1 1/2 side tube inlet	1 1/16 - 12, SAE side ORB	204 [54]
717	1 1/2 side tube inlet	7/8 - 14, SAE side ORB	204 [54]

D Series Cast Iron Gear Pumps

Technical Information

Options

Rear Cover – Port Options, Integrated Valves and Auxiliary Flange

SAE O-ring boss ports - No integrated valves - No auxiliary flange

Code	Inlet port	Outlet port	Maximum recommended inlet flow l/min [US gal/min]
N101	1 1/16 - 12, SAE side	7/8 - 14, SAE side	49 [13]
N103	1 5/16 - 12, SAE side	7/8 - 14, SAE side	91 [24]
N104	1 5/16 - 12, SAE side	1 1/16 - 12, SAE side	91 [24]
N113	None*	7/8 - 14 SAE, side	- N/A -
N126	None*	1 1/16 - 12, side	- N/A -

* Used with multiple pump configurations

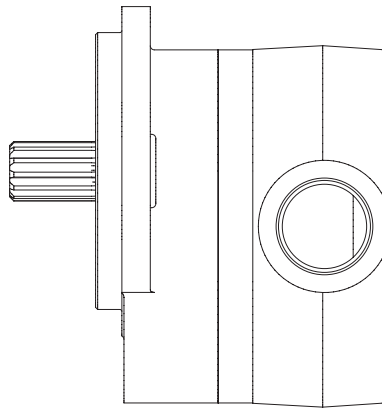

P104 268E

Code	Inlet port	Outlet port	Maximum recommended inlet flow l/min [US gal/min]
N125	1 5/8 - 12, SAE, side	1 1/16 - 12, SAE, side	151 [40]

Dimensions mm [in]

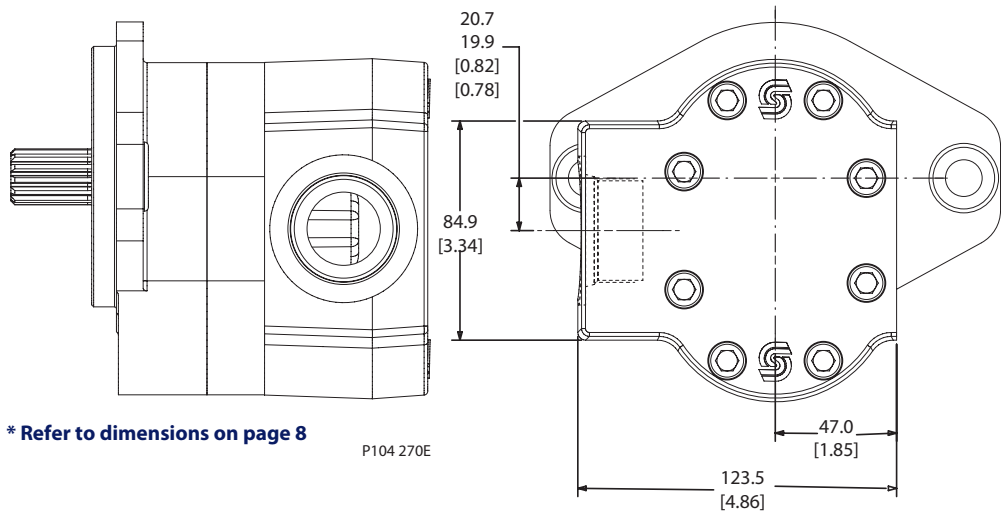

* Refer to dimensions on page 8

P104 270E

D Series Cast Iron Gear Pumps Technical Information Options

Rear Cover – Port Options, Integrated Valves and Auxiliary Flange (continued)

SAE O-ring boss ports - No integrated valves - No auxiliary flange

Code	Inlet port	Outlet port	Maximum recommended inlet flow l/min [US gal/min]
N501	1 1/16 - 12, SAE rear	7/8 - 14 SAE, rear	49 [13]
N503	1 5/16 - 12, SAE rear	7/8 - 14, rear	91 [24]
N504	1 5/16 - 12, SAE rear	1 1/16 - 12, SAE rear	91 [24]

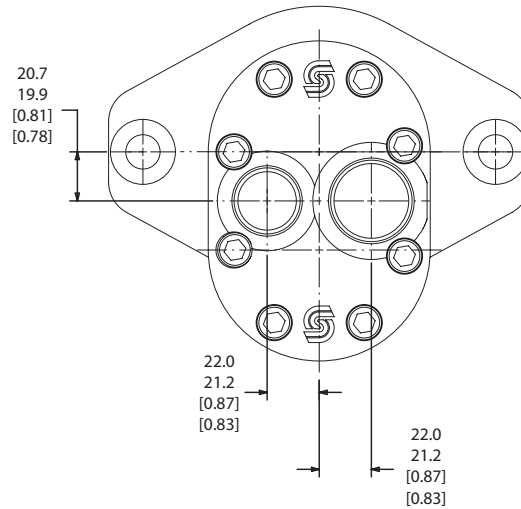

Dimensions mm [in]

P104 269

Beaded tube inlet port, SAE O-ring boss ports - No integrated valves - No auxiliary flange

Code	Inlet port	Outlet port	Maximum recommended inlet flow l/min [US gal/min]
N704	1 1/4 inch side	7/8 - 14 ORB side	151 [40]
N708	1 1/4 inch side	1 1/16-12 ORB side	151 [40]
N715	1 1/4 inch rear	1 1/16-12 ORB rear	151 [40]
N720	1 1/4 inch side	7/8 - 14 ORB rear	151 [40]

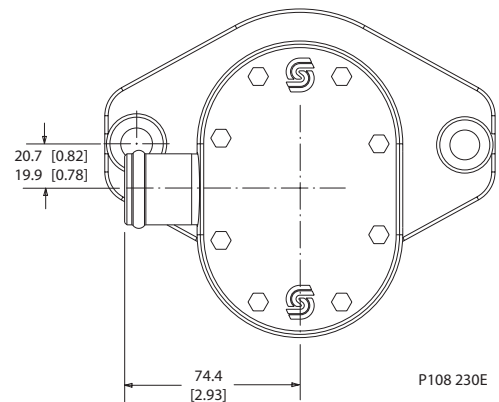
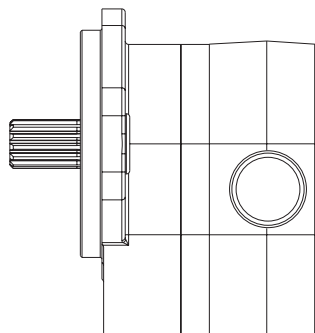

P108 230E

D Series Cast Iron Gear Pumps

Technical Information

Options

Rear Cover – Port Options, Integrated Valves and Auxiliary Flange (continued)

SAE-A 2-bolt auxiliary flange - SAE O-ring boss ports - No integrated valves

D Series pumps are available with an optional SAE-A 2-bolt auxiliary flange. Benefits include:

- Flexibility to auxiliary mount any product with SAE-A mounting flange
- Easily combine different product families including D Series with SNP2 aluminum pumps
- Enables sealing between sections to keep fluids isolated for applications where fluids may be drawn from different reservoirs or where sections operate with different fluid types
- Provides capability for customer add-on option

Code	Auxiliary drive	Inlet port	Outlet port	Maximum recommended inlet flow l/min [US gal/min]
B103*	SAE-A 2-bolt, 9T	1 5/16-12 side	7/8 - 14 side	91 [24]
B104*	SAE-A 2-bolt, 9T	1 5/16-12 side	1 1/16-12 side	91 [24]

*Auxiliary flange requires use of input shaft option AC or AH

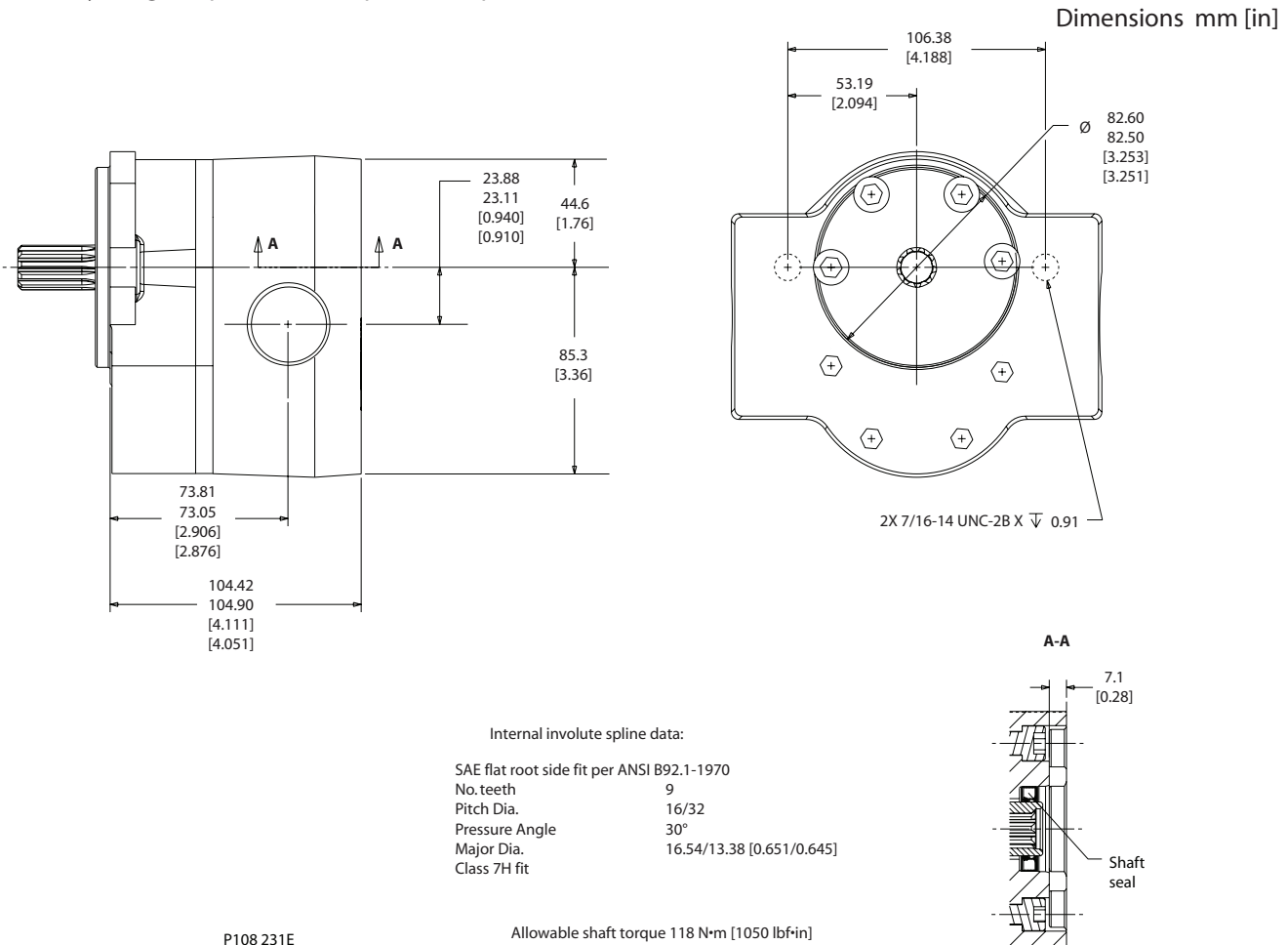

The auxiliary flange option does not ship with a running cover. If the pump will be operated without an auxiliary pump, install a running cover to prevent environmental contamination.

D Series Cast Iron Gear Pumps

Technical Information

Options

Rear Cover – Port Options, Integrated Valves and Auxiliary Flange (continued)

Integrated Priority Flow Divider

D series pumps are available with an optional Priority Flow Divider (PFD) valve integrated into the rear cover. The PFD divides the flow and provides a fixed amount of Controlled Flow (CF) to priority functions such as steering. The remaining flow is routed to the Excess Flow (EF) port for additional functions such as directional control valves and fan drives. The priority flow is pressure compensated and is therefore independent of the excess flow working pressures. The priority flow circuit has an integral, direct acting pilot relief valve with internal drain.

Two styles of relief valves are available to suit application pressure and flow requirements.

- Parts-in body relief- pressures to 138 bar (2000 psi), flows to 22.7 l/min (6 US gal/m)
- Cartridge style relief - pressures to 221 bar (3200 psi), flows to 34.3 l/min (9 US gal/m)

The D series PFD can be used in tandems and other multiple pump configurations, but only in the rear pumping section. A variety of port sizes and port locations are available. Pumps with PFD covers are rotation specific and require a unique front mounting flange to accommodate the spacing of the assembly bolts.

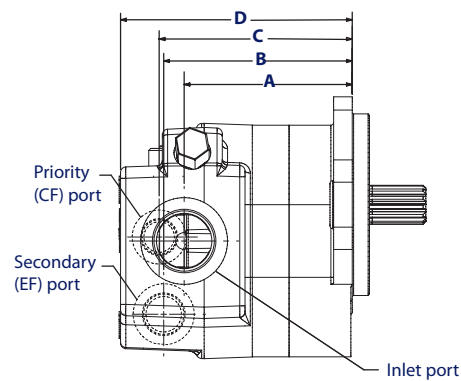
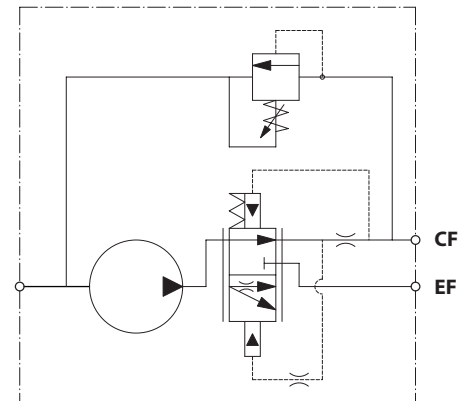

Illustration of right-hand (CW) rotation
Refer to dimensions on page 8

P104 274E



P106 105E

Description	Code	07	10	13	14	17	19	21	23	25	29	32	36	38	41	45
Displacement	cm ³ /rev	7.0	9.5	12.6	14.3	17.0	19.0	20.5	22.5	25.4	29.0	31.8	36.0	38.0	41.0	45.1
	in ³ /rev	0.43	0.58	0.77	0.87	1.04	1.16	1.25	1.37	1.55	1.77	1.94	2.20	2.32	2.50	2.75
Weight	kg	8.8	9.0	9.2	9.3	9.4	9.6	9.6	9.8	9.9	10.1	10.3	10.6	10.7	10.7	11.0
	lb	19.5	19.8	20.2	20.4	20.8	21.1	21.2	21.5	21.9	22.3	22.7	23.3	23.5	23.9	24.4
Dimension A1 Inlet port distance up to 1-5/16 SAE	mm	80.5	82.9	86.1	88.3	90.4	92.5	94.0	95.8	98.8	102.4	105.2	109.4	111.4	114.4	118.6
	in	3.17	3.27	3.39	3.48	3.56	3.64	3.70	3.77	3.89	4.03	4.14	4.31	4.39	4.50	4.67
Dimension A2 Inlet port distance 1-5/8 SAE	mm	90.2	92.6	95.8	97.9	100.1	102.1	103.6	105.5	108.5	112.0	114.8	119.1	121.1	124.1	128.3
	in	3.55	3.65	3.77	3.86	3.94	4.02	4.08	4.15	4.27	4.41	4.52	4.69	4.77	4.88	5.05
Dimension B Secondary port distance	mm	91.9	94.4	97.5	99.7	101.9	103.9	105.4	107.3	110.2	113.8	116.6	120.9	122.8	125.8	130.0
	in	3.62	3.72	3.84	3.93	4.01	4.09	4.15	4.22	4.34	4.48	4.59	4.76	4.84	4.95	5.12
Dimension C priority port distance	mm	94.5	96.9	100.1	102.2	104.4	106.4	108.0	109.8	112.8	116.4	119.1	123.4	125.4	128.4	132.6
	in	3.72	3.82	3.94	4.03	4.11	4.19	4.25	4.32	4.44	4.58	4.69	4.86	4.94	5.05	5.22
Dimension D overall length	mm	116.1	118.5	121.7	123.8	126.0	128.0	129.5	131.4	134.4	137.9	140.7	145.0	147.0	150.0	154.2
	in	4.57	4.67	4.79	4.88	4.96	5.04	5.10	5.17	5.29	5.43	5.54	5.71	5.79	5.90	6.07

Rear Cover - Port Options, Integrated Valves and Auxiliary Flange (continued)

Integrated Priority Flow Divider (continued)

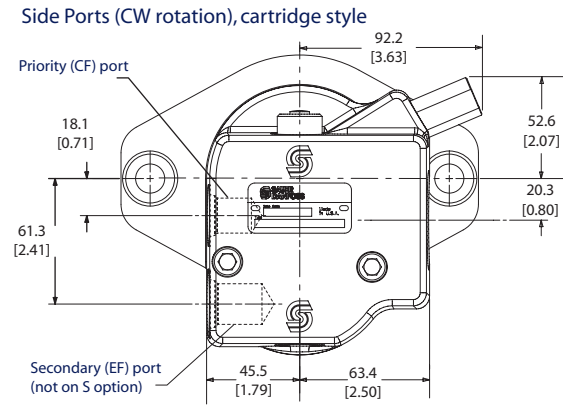

Side Ports (CCW rotation), cartridge style

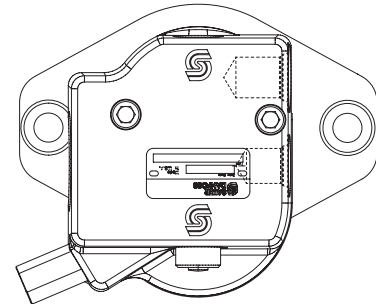

P108 182E

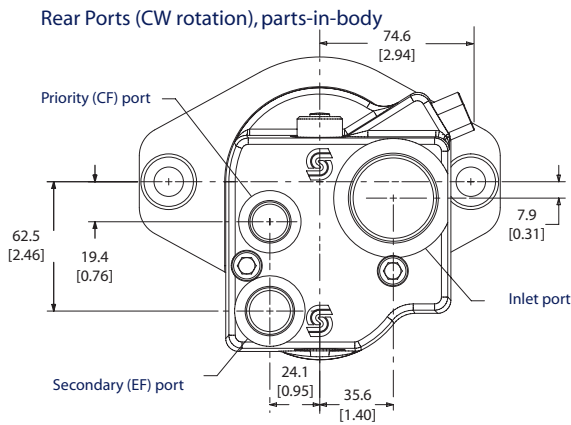

Rear Ports (CCW rotation), parts-in-body

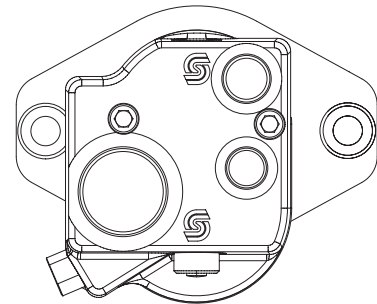

P108 183E

Integrated priority flow dividers require use of mounting flange options AC, AB, AP or BF.

D Series Cast Iron Gear Pumps Technical Information Options

Rear Cover - Port Options, Integrated Valves and Auxiliary Flange (continued)

Integrated Steering Cover

D series pumps are available with an optional steering valve integrated into the rear cover. The steering valve provides a fixed amount of Controlled Flow (CF) for priority functions such as steering. The remaining flow is routed internally to the inlet. The control flow circuit has an integral, direct acting pilot relief valve with internal drain. The relief valve is a parts-in-body design suitable for pressures to 138 bar (2000 psi) and flows to 22.7 l/min (6 US gal/m).

The D series steering cover can be used in tandems and other multiple pump configurations, but only in the rear pumping section. A variety of port sizes and port locations are available. Pumps with steering covers are rotation specific and require a unique front mounting flange to accommodate the spacing of the assembly bolts.

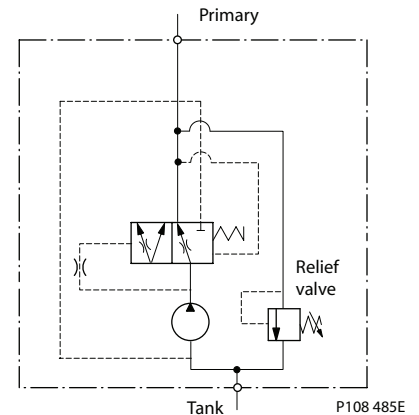

Integrated Priority Flow Divider, cartridge style relief for settings up to 221bar and 34.3 l/min [3200 psi and 9 US gal/min]	
Code	Description
F09A	1 5/16-12 side inlet, 3/4-16 side priority, 7/8-14 side secondary (SAE A flange)
F09B	1 5/16-12 side inlet, 3/4-16 side priority, 7/8-14 side secondary (SAE B flange)
F13A	1 5/8-12 rear inlet, 3/4-16 rear priority, 7/8-14 rear secondary (SAE A flange)
F13B	1 5/8-12 rear inlet, 3/4-16 rear priority, 7/8-14 rear secondary (SAE B flange)
F21A	1 5/8-12 side inlet, 3/4-16 side priority, 7/8-14 side secondary (SAE A flange)
F21B	1 5/8-12 side inlet, 3/4-16 side priority, 7/8-14 side secondary (SAE B flange)
F25A	1 5/16-12 rear inlet, 3/4-16 rear priority, 7/8-14 rear secondary (SAE A flange)
F25B	1 5/16-12 rear inlet, 3/4-16 rear priority, 7/8-14 rear secondary (SAE B flange)

Integrated Priority Flow Divider, parts-in body relief for settings up to 138 bar and 22.7 l/min [2000 psi and 6 US gal/min]	
Code	Description
P09A	1 5/16-12 side inlet, 3/4-16 side priority, 7/8-14 side secondary (SAE A flange)
P09B	1 5/16-12 side inlet, 3/4-16 side priority, 7/8-14 side secondary (SAE B flange)

Rear Cover - Port Options, Integrated Valves and Auxiliary Flange (continued)

Integrated Steering Cover (continued)

Integrated Steering Cover, parts-in body relief for settings up to 138 bar and 22.7 l/min [2000 psi and 6 US gal/min]*	
Code	Description
S23A	1 5/16-12 side inlet, 3/4-16 side priority, use with SAE-A mounting flange
S23B	1 5/16-12 side inlet, 3/4-16 side priority, use with SAE-B mounting flange

* Requires use of mounting flange option AC, BC, AP or BP

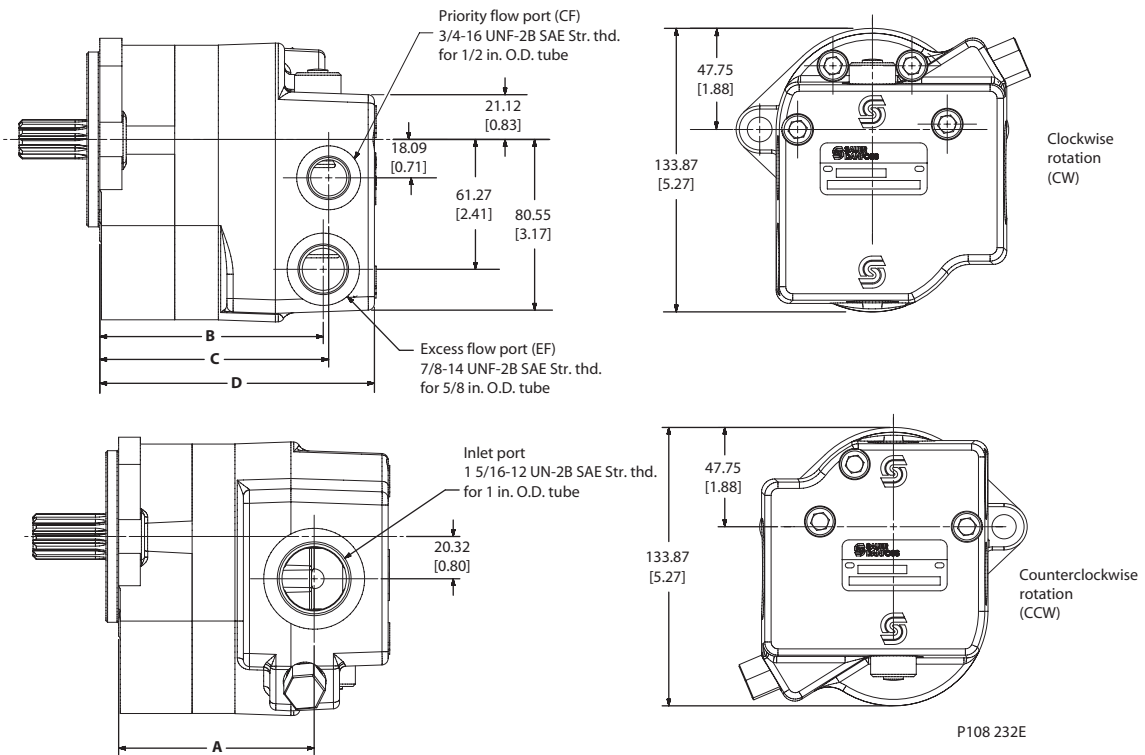

Dimension	Displacement cm ³ /rev [in ³ /rev]															
	7.0 [0.43]	9.5 [0.58]	12.6 [.077]	14.3 [0.87]	17.0 [1.04]	19.0 [1.16]	20.5 [1.25]	22.5 [1.37]	25.4 [1.55]	29.0 [1.77]	31.8 [1.94]	36.0 [2.20]	38.0 [2.32]	41.0 [2.50]	45.1 [2.75]	
A	mm	80.5	82.9	86.1	87.8	90.4	92.5	94.0	95.8	98.8	102.4	105.2	109.4	111.4	114.4	118.6
	in	3.17	3.27	3.39	3.46	3.56	3.64	3.70	3.77	3.89	4.03	4.14	4.31	4.39	4.50	4.67
B	mm	92.0	94.4	97.5	99.2	101.9	103.9	105.4	107.3	110.2	113.8	116.6	120.9	122.8	125.8	130.1
	in	3.62	3.72	3.84	3.91	4.01	4.09	4.15	4.22	4.34	4.48	4.59	4.76	4.84	4.95	5.12
C	mm	94.5	96.9	100.1	101.7	104.4	106.4	108.0	109.8	112.8	116.4	119.1	123.4	125.4	128.4	132.6
	in	3.72	3.82	3.94	4.01	4.11	4.19	4.25	4.32	4.44	4.58	4.69	4.86	4.94	5.05	5.22
D	mm	116.1	118.5	121.7	123.3	126.0	128.0	129.6	131.4	134.4	138.0	140.7	145.0	147.0	150.0	154.2
	in	4.57	4.67	4.79	4.86	4.96	5.04	5.10	5.17	5.29	5.43	5.54	5.71	5.79	5.90	6.07

D Series Cast Iron Gear Pumps Technical Information Options

Rear Cover - Port Options, Integrated Valves and Auxiliary Flange (continued)

Load Sense Priority Flow Valve

D series pumps are available with an optional Load Sense (LS) priority valve integrated into the rear cover. The LS priority valve supplies priority flow on demand to functions such as load sense steering, while the Excess Flow (EF) is available for secondary functions such as directional control valves and fan drives.

A load sense signal line from the priority circuit to the gear pump's LS port governs flow to the primary circuit. As the load sense signal pressure increases, priority (CF) flow also increases. When the controlled function is idle (no load sense demand), full pump flow is available for the secondary functions.

- The D series LS priority valve is available with 40 l/min [10 US gal/min] and 80 l/min [21 US gal/min] flow settings.
- The priority circuit is available with an optional integral direct acting pilot relief valve with internal drain. Pressure settings range from 34 to 172 bar [500 to 2500 psi].
- The load sense valve is dynamic and has a constant flow of 0.5 to 1.0 l/min [0.13 to 0.26 US gal/min] present at all times to ensure fast reaction.
- The D series PFD can be used in tandems and other multiple pump configurations, but only in the rear pumping section.
- Rear and side porting options are available.

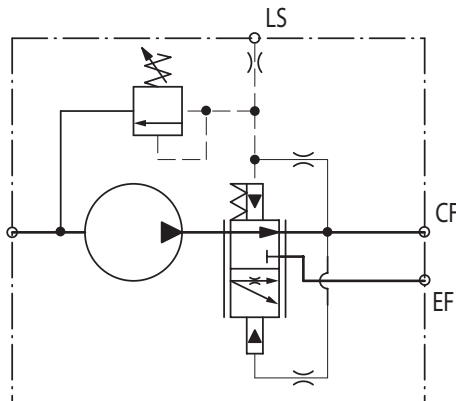

P104 279

Contact your TurolldOCG representative for information concerning load sense port options.

Rear Cover - Port Options, Integrated Valves and Auxiliary Flange (continued)

Pumps with Load Sense Priority Flow Valves

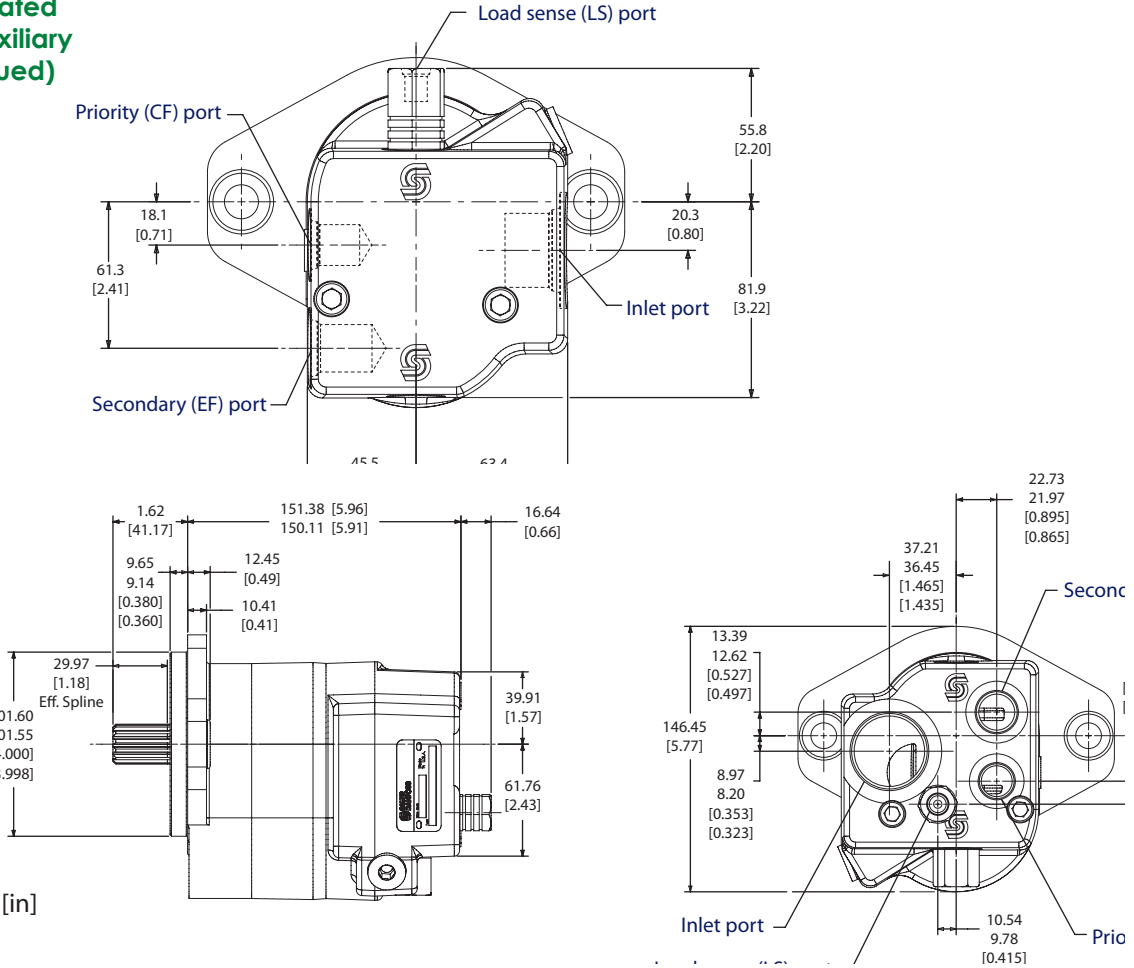

Dimensions mm [in]

Load Sense Pump Dimensions

Description	Code	07	10	11	13	14	17	19	21	23	25	29	32	36	38	41	45
Displacement	cm ³ /rev	7.0	9.5	10.8	12.6	14.3	17.0	19.0	20.5	22.5	25.4	29.0	31.8	36.0	38.0	41.0	45.1
	in ³ /rev	0.43	0.58	0.66	0.77	0.87	1.04	1.16	1.25	1.37	1.55	1.77	1.94	2.20	2.32	2.50	2.75
Weight	kg	8.8	9.0	9.1	9.2	9.3	9.4	9.6	9.6	9.8	9.9	10.1	10.3	10.6	10.7	10.7	11.0
	lb	19.5	19.8	20.0	20.2	20.4	20.8	21.1	21.2	21.5	21.9	22.3	22.7	23.3	23.5	23.9	24.4
Dimension A1 Inlet port distance sizes up to 1-5/16 in SAE	mm	80.5	82.9	84.5	86.1	88.3	90.4	92.5	94.0	95.8	98.8	102.4	105.2	109.4	111.4	114.4	118.6
	in	3.17	3.27	3.31	3.39	3.48	3.56	3.64	3.70	3.77	3.89	4.03	4.14	4.31	4.39	4.50	4.67
Dimension A2 Inlet port distance 1-5/8 in SAE	mm	90.2	92.6	94.0	95.8	97.9	100.1	102.1	103.6	105.5	108.5	112.0	114.8	119.1	121.1	124.1	128.3
	in	3.55	3.65	3.69	3.77	3.86	3.94	4.02	4.08	4.15	4.27	4.41	4.52	4.69	4.77	4.88	5.05
Dimension B Secondary port distance	mm	91.9	94.4	95.8	97.5	99.7	101.9	103.9	105.4	107.3	110.2	113.8	116.6	120.9	122.8	125.8	130.0
	in	3.62	3.72	3.78	3.84	3.93	4.01	4.09	4.15	4.22	4.34	4.48	4.59	4.76	4.84	4.95	5.12
Dimension C priority port distance	mm	94.5	96.9	98.5	100.1	102.2	104.4	106.4	108.0	109.8	112.8	116.4	119.1	123.4	125.4	128.4	132.6
	in	3.72	3.82	3.88	3.94	4.03	4.11	4.19	4.25	4.32	4.44	4.58	4.69	4.86	4.94	5.05	5.22
Dimension D overall length	mm	116.1	118.5	120.0	121.7	123.8	126.0	128.0	129.5	131.4	134.4	137.9	140.7	145.0	147.0	150.0	154.2
	in	4.57	4.67	4.71	4.79	4.88	4.96	5.04	5.10	5.17	5.29	5.43	5.54	5.71	5.79	5.90	6.07

Dimensions

One Section (Single)

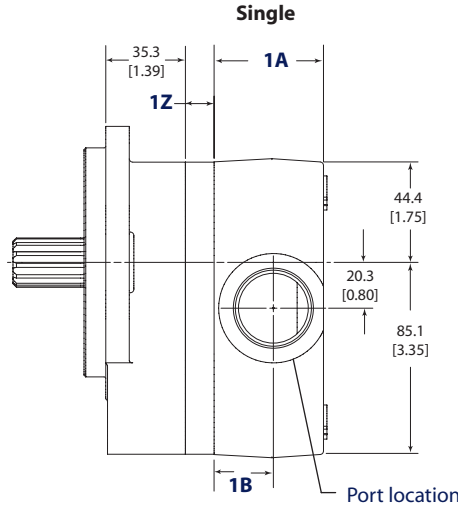

Dimension	Section 1	
	1A	1B
Standard Ports: N101, N103, N113, N126, N501, N503, N504	45 [1.91]	24 [0.96]
Oversized Ports N125, N704, N708	63.5 [2.5]	31.75 [1.25]

P108 179E

Displacement	Units	07	10	11	13	14	17	19	21	23	25	29	32	36	38	41	45
Dimension Z	mm	7.1	9.7	10.9	12.7	14.4	17.0	19.1	20.6	22.5	25.4	29.0	31.8	36.1	38.1	41.0	45.2
	in	0.28	0.38	0.43	0.50	0.57	0.67	0.75	0.81	0.88	1.00	1.14	1.25	1.42	1.50	1.61	1.78

How to determine overall length

The overall length of the single section pump (as measured from the mounting flange) can be calculated by adding the dimension of the mounting flange to the combined length of the pumping section. The length of the pumping section is dependent upon the displacement (dimension Z) and the selection of ports (standard or oversized).

$$\text{Overall length of single section pump} = 35.3 [1.39] + 1Z + 1A$$

How to determine the position of inlet/outlet ports

Generally speaking, the inlet and outlet ports are centrally located within each port section. Therefore, the position of the inlet/outlet port (as measured from the mounting flange) can be calculated as follows:

$$\text{Location of port 1} = 35.3 [1.39] + 1Z + 1B$$

Dimensions (continued)

Two Section - Tandem

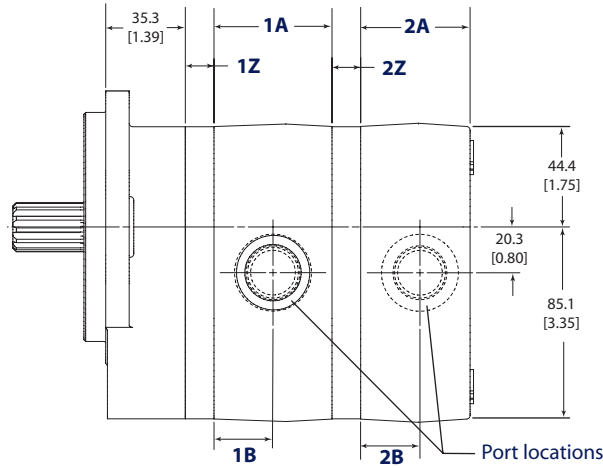

P108 177E

Dimension	Section 1		Section 2	
	1A	1B	2A	2B
Standard Ports: 101, 103, 104, 113, 126, 704, 708 N101, N103, N113, N126, N501, N503, N504	52.3 [2.06]	26.15 [1.03]	48.5 [1.91]	24.25 [1.03]
Oversized Ports: 125, 716, 717, N125, N704, N708	61.2 [2.4]	30.6 [1.2]	63.5 [2.5]	31.75 [1.25]

Displacement	Units	07	10	11	13	14	17	19	21	23	25	29	32	36	38	41	45
Dimension Z	mm	7.1	9.7	10.9	12.7	14.4	17.0	19.1	20.6	22.5	25.4	29.0	31.8	36.1	38.1	41.0	45.2
	in	0.28	0.38	0.43	0.50	0.57	0.67	0.75	0.81	0.88	1.00	1.14	1.25	1.42	1.50	1.61	1.78

How to determine overall length

The overall length of the two section pump (as measured from the mounting flange) can be calculated by adding the dimension of the mounting flange to the combined length of each section. The length of the section is dependent upon the displacement (dimension Z) and the selection of ports (standard or oversized).

$$\text{Overall length of two section pump} = 35.3 [1.39] + 1Z + 1A + 2Z + 2A$$

How to determine the position of inlet/outlet ports

Generally speaking, the inlet and outlet ports are centrally located within each port section. Therefore, the position of each port (as measured from the mounting flange) can be calculated as follows:

$$\text{Location of port 1} = 35.3 [1.39] + 1Z + 1B$$

$$\text{Location of port 2} = 35.3 [1.39] + 1Z + 1A + 2Z + 2B$$

**Dimensions
(continued)**

Three Section - Triple

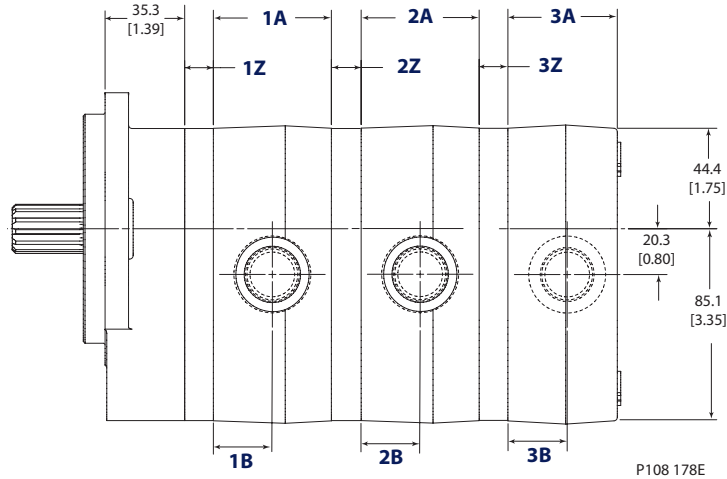

Dimension	Section 1 and 2		Section 3	
	1A	1B	2A	2B
Standard Ports: 101, 103, 104, 113, 126, 704, 708 N101, N103, N113, N126, N501, N503, N504	52.3 [2.06]	26.15 [1.03]	48.5 [1.91]	24.25 [1.03]
Oversized Ports: 125, 716, 717, N125, N704, N708	61.2 [2.4]	30.6 [1.2]	63.5 [2.5]	31.75 [1.25]

Displacement	Units	07	10	11	13	14	17	19	21	23	25	29	32	36	38	41	45
Dimension Z	mm	7.1	9.7	10.9	12.7	14.4	17.0	19.1	20.6	22.5	25.4	29.0	31.8	36.1	38.1	41.0	45.2
	in	0.28	0.38	0.43	0.50	0.57	0.67	0.75	0.81	0.88	1.00	1.14	1.25	1.42	1.50	1.61	1.78

How to determine overall length

The overall length of the three section pump (as measured from the mounting flange) can be calculated by adding the dimension of the mounting flange to the combined length of each pumping section. The length of each pumping section is dependent upon the displacement (dimension Z) and the selection of ports (standard or oversized).

$$\text{Overall length of three section pump} = 35.3 [1.39] + 1Z + 1A + 2Z + 2A + 3Z + 3A$$

How to determine the position of inlet/outlet ports

Generally speaking, the inlet and outlet ports are centrally located within each port section. Therefore, the position of each port (as measured from the mounting flange) can be calculated as follows:

$$\text{Location of port 1} = 35.3 [1.39] + 1Z + 1B$$

$$\text{Location of port 2} = 35.3 [1.39] + 1Z + 1A + 2Z + 2B$$

$$\text{Location of port 3} = 35.3 [1.39] + 1Z + 1A + 2Z + 2A + 3Z + 3B$$

Dimensions (continued)

Four Section - Quad

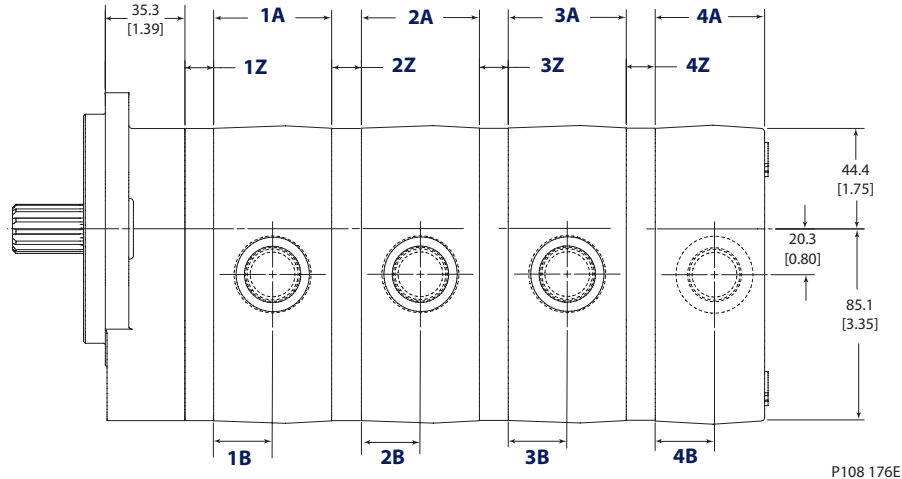

Dimension	Section 1, 2, 3		Section 4	
	1A	1B	2A	2B
Standard Ports: 101, 103, 104, 113, 126, 704, 708 N101, N103, N113, N126, N501, N503, N504	52.3 [2.06]	26.15 [1.03]	48.5 [1.91]	24.25 [1.03]
Oversized Ports: 125, 716, 717, N125, N704, N708	61.2 [2.4]	30.6 [1.2]	63.5 [2.5]	31.75 [1.25]

Displacement	Units	07	10	11	13	14	17	19	21	23	25	29	32	36	38	41	45
Dimension Z	mm	7.1	9.7	10.9	12.7	14.4	17.0	19.1	20.6	22.5	25.4	29.0	31.8	36.1	38.1	41.0	45.2
	in	0.28	0.38	0.43	0.50	0.57	0.67	0.75	0.81	0.88	1.00	1.14	1.25	1.42	1.50	1.61	1.78

How to determine overall length

The overall length of the four section pump (as measured from the mounting flange) can be calculated by adding the dimension of the mounting flange to the combined length of each pumping section. The length of each pumping section is dependent upon the displacement (dimension Z) and the selection of ports (standard or oversized).

$$\text{Overall length of four section pump} = 35.3 [1.39] + 1Z + 1A + 2Z + 2A + 3Z + 3A + 4Z + 4A$$

How to determine the position of inlet/outlet ports

Generally speaking, the inlet and outlet ports are centrally located within each port section. Therefore, the position of each port (as measured from the mounting flange) can be calculated as follows:

$$\text{Location of port 1} = 35.3 [1.39] + 1Z + 1B$$

$$\text{Location of port 2} = 35.3 [1.39] + 1Z + 1A + 2Z + 2B$$

$$\text{Location of port 3} = 35.3 [1.39] + 1Z + 1A + 2Z + 2A + 3Z + 3B$$

$$\text{Location of port 4} = 35.3 [1.39] + 1Z + 1A + 2Z + 2A + 3Z + 3A + 4Z + 4B$$

Flow performance

The graphs on this, and the following pages, show output flow for the D series single pumps at various working pressures as a function of speed. Data were taken using hydraulic fluid conforming to ISO VG46 at 50°C (120° F) with viscosity at 28 mm²/sec (cSt) [132 SUS].

Model 07D (l/min)

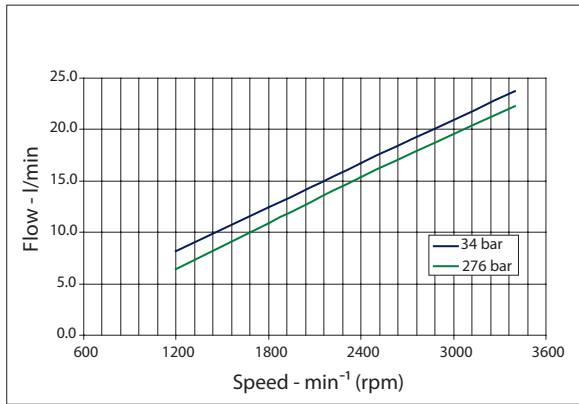

Model 07D (US gal/min)

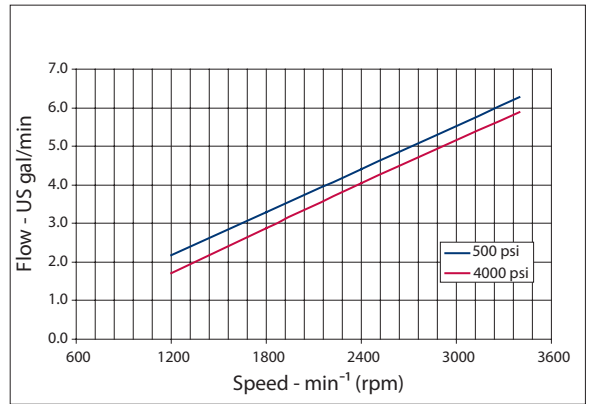

Model 10D (l/min)

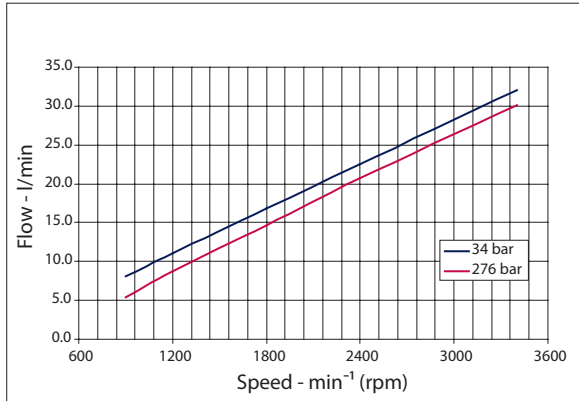

Model 10D (US gal/min)

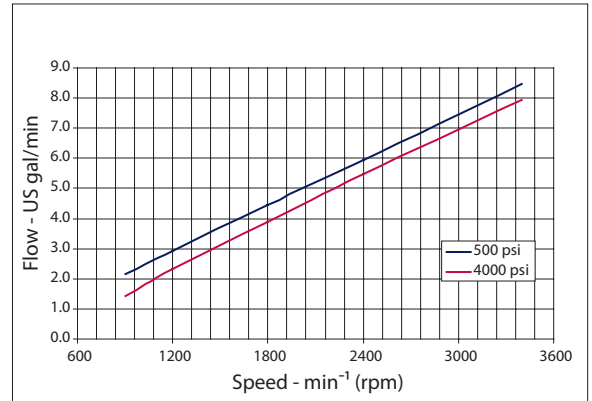

Model 13D (l/min)

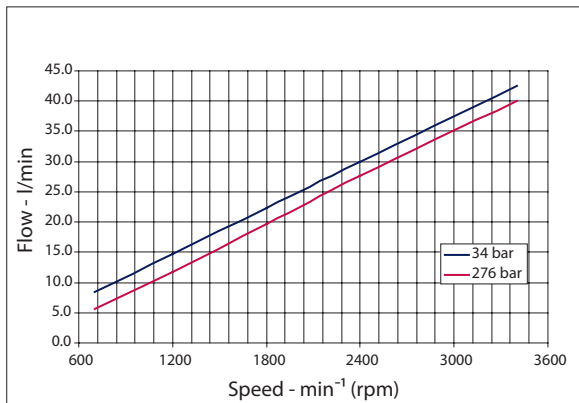

Model 13D (US gal/min)

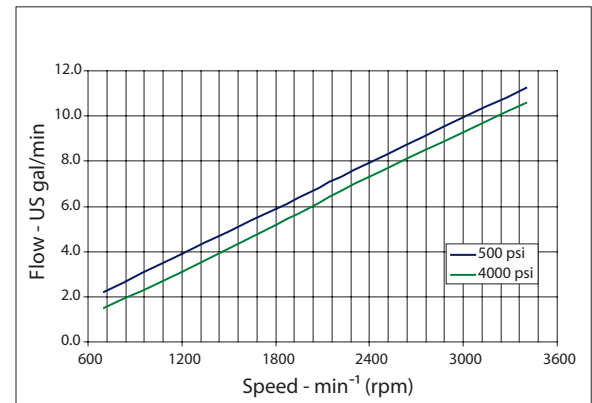

Flow performance (continued)

Model 14D (l/min)

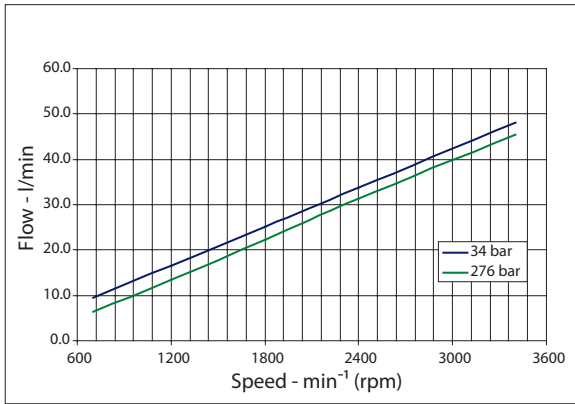

Model 14D (US gal/min)

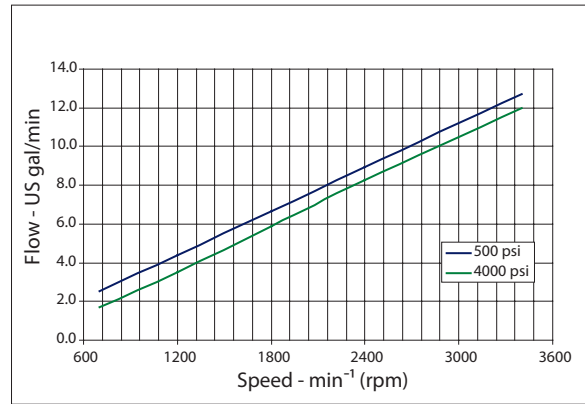

Model 17D (l/min)

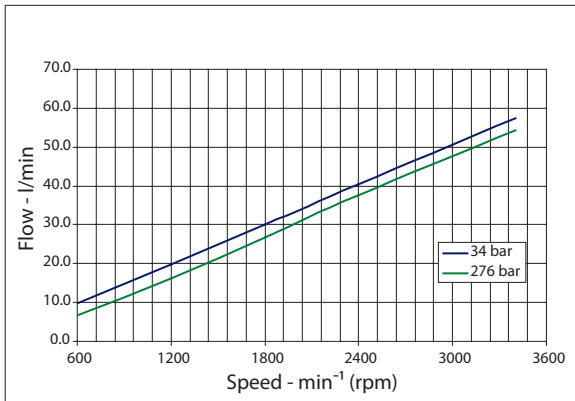

Model 17D (US gal/min)

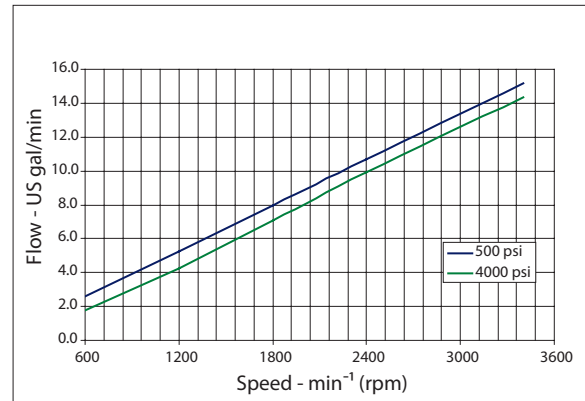

Model 19D (l/min)

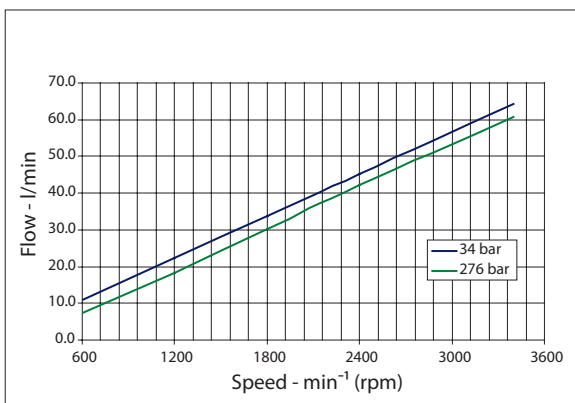

Model 19D (US gal/min)

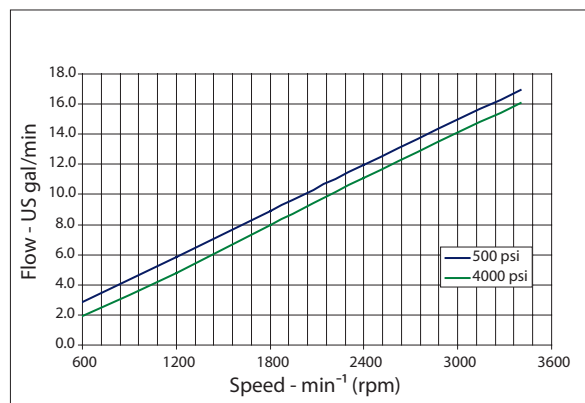

Flow performance (continued)

Model 21D (l/min)

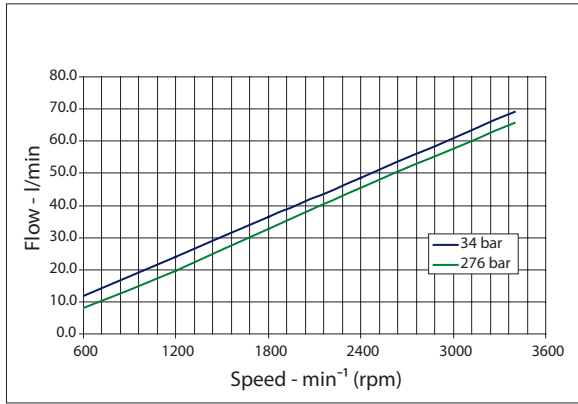

Model 21D (US gal/min)

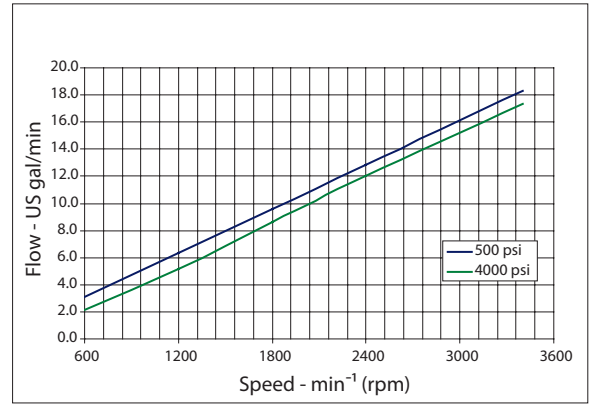

Model 23D (l/min)

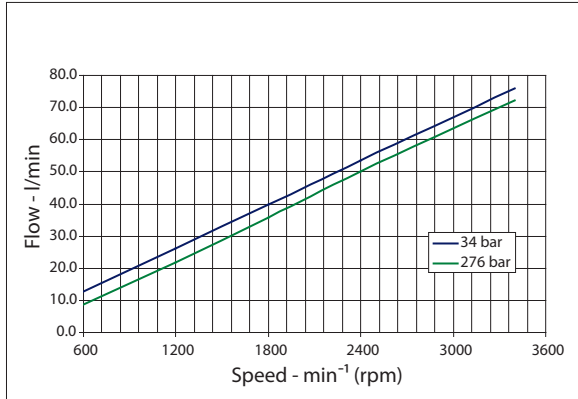

Model 23D (US gal/min)

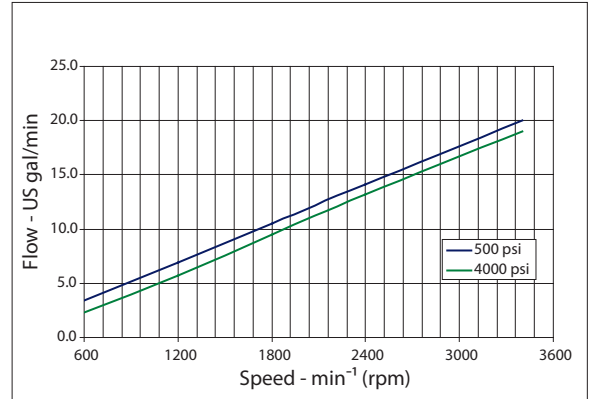

Model 25D (l/min)

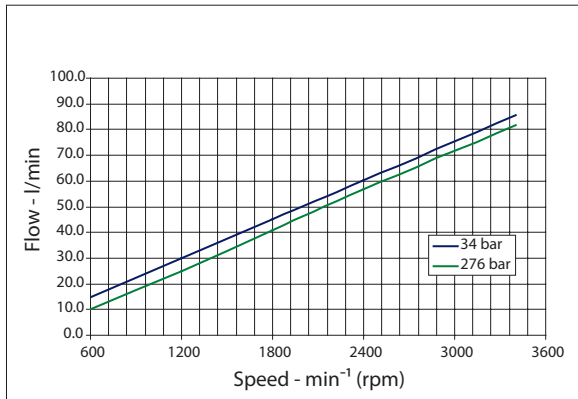

Model 25D (US gal/min)

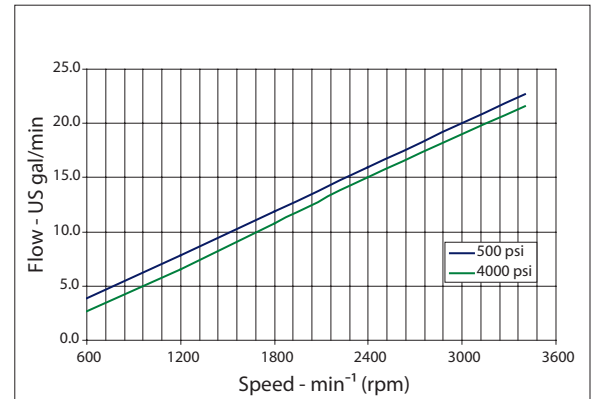

Flow performance (continued)

Model 29D (l/min)

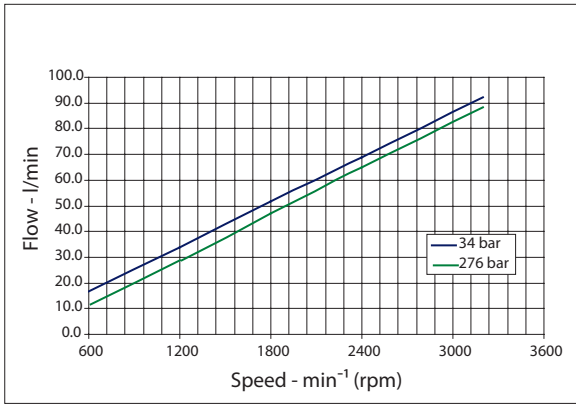

Model 29D (US gal/min)

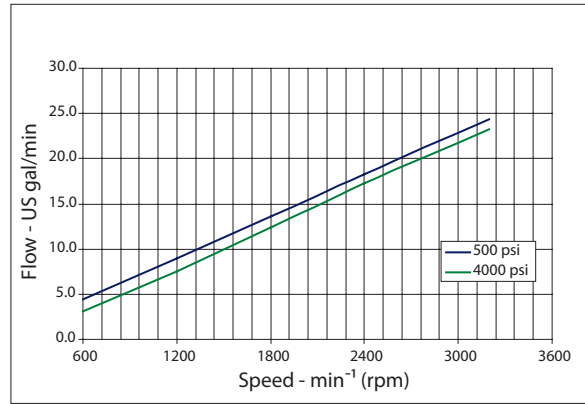

Model 32D (l/min)

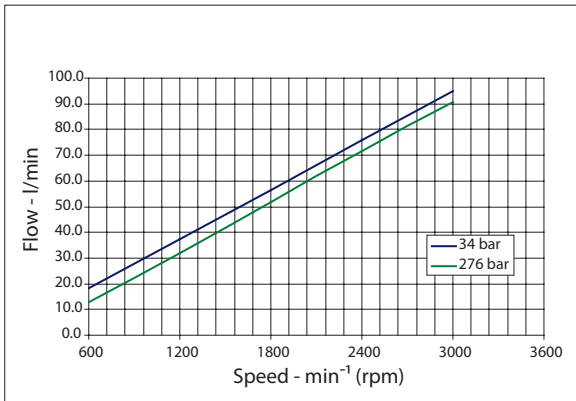

Model 32D (US gal/min)

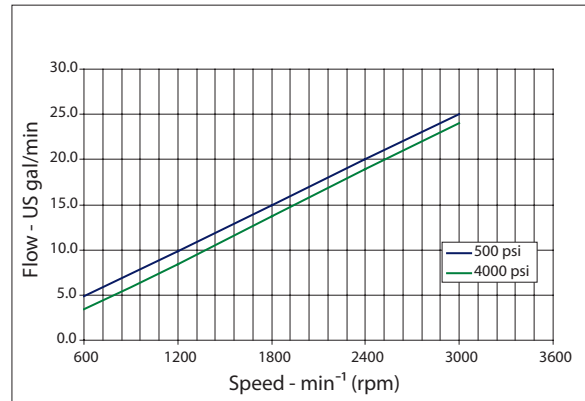

Model 38D (l/min)

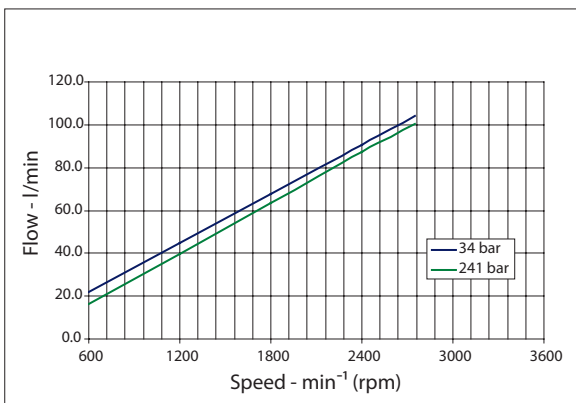

Model 38D (US gal/min)

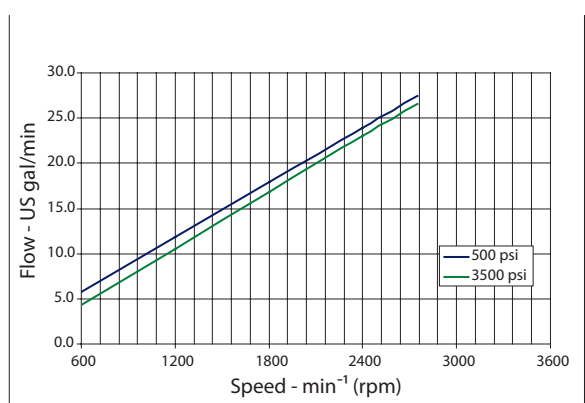

Flow performance (continued)

Model 41D (l/min)

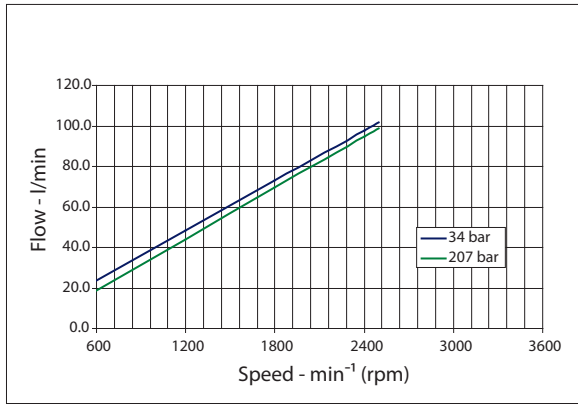

Model 41D (US gal/min)

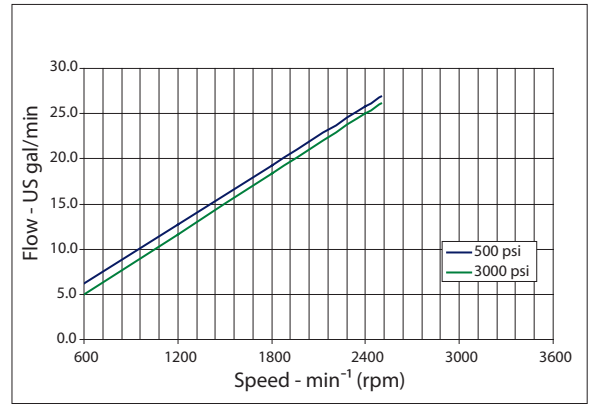

Model 45D (l/min)

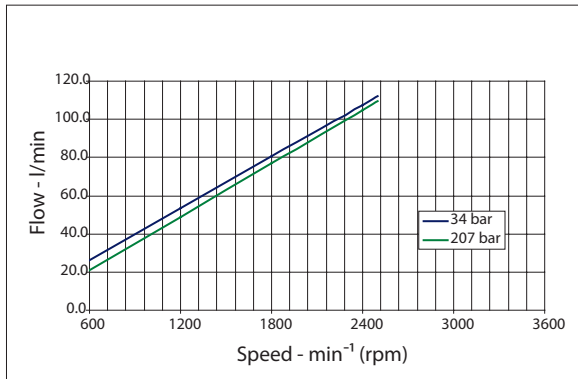

Model 45D (US gal/min)

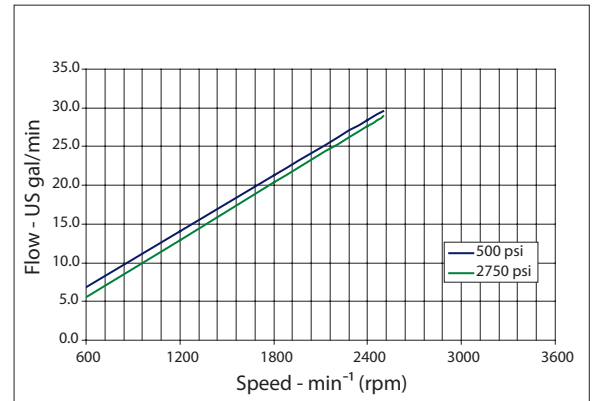

D Series Cast Iron Gear Pumps Technical Information Reference Literature

TurollaOCG Literature

Literature reference - Software

Title	Type	Order number
SX Microcontroller Fan Drive Personality	Technical Information	11023458

Literature reference - Fan Drive Controls

Title	Type	Order number
Fan Drive Control	Technical Information	11005336
Fan Drive Control Assembly	Technical Information	11005337
Fan Drive Control Temperature Sensors	Technical Information	BLN-95-9063
PLUS+1 compliant Heavy-Duty Pressure Transmitter	Datasheet	520L0801
PLUS+1 compliant Heavy-Duty Pressure Transmitter - SAE Thread Version	Datasheet	11005452
PLUS+1 MC088 015-00000-Controller	Datasheet	11006645

Literature reference - Pumps and Motors

Title	Type	Order number
Series D Hydraulic Gear Pumps	Technical Information	L1022940
Group 1 Gear Pumps	Technical Information	L1016399
Group 2 Gear Pumps	Technical Information	L1016341
Group 3 Gear Pumps	Technical Information	L1016456
Group 1, 2 and 3 Gear Motors	Technical Information	L1016082
SGM2, SGM3 Fan Drive Gear Motors	Technical Information	L1016036
SGM2 Fan Drive Gear Motors	Datasheet	11029652
SGM3 Fan Drive Gear Motors	Datasheet	11056719
Series 45 Open Circuit Pumps	Technical Information	520L0519

Literature reference - Fluids

Title	Type	Order number
Hydraulic Fluids and Lubricants	Technical Information	L1021414



Factory 19 / 5 Lyn Parade PRESTONS NSW 2170

Ph: (02) 9607 4100 Fax: (02) 9607 4200